

PR S1 RM

1/10 SCALE ELECTRIC POWERED 2WD BUGGY KIT



Features:

1. Chassis: 3.0mm aluminum alloy chassis CNC machined for optimum flex.
2. Suspension: Precision aluminum shock bodies for smooth and consistent dampening.
3. Driveshafts: Universal shafts featuring the same design specs of the Type R model.
4. Motor Plate: 2.5mm thick aluminum alloy is lightweight yet durable.
5. Wheel Hexes: Machined aluminum for strength and precise fit.
6. Spur Gear: Standard dual pad slipper system.
7. Suspension Arms: Front and rear gull-wing suspension arms with optimized Type R geometry.
8. Front Steering Knuckle Plates: Made of 2.5mm carbon fiber.

www.pr-rc.com

#71400438

PR S1 RM 1:10 Scale 2WD Off Road Electric Buggy Kit



2WD ELECTRIC 1-10 KIT

● BEFORE INSTALLATION -----	01-02
● BAG A -----	03-06
Chassis Guard Installation	
Steering Bellcranks	
Steering Servo	
● BAG B -----	06-11
Front Wishbone	
Front Spindle[Left Side]	
Front Suspension system(L&R)	
Front Shock Stay	
Front Upper Turnbuckle Assembly	
Rear Hub & CVA L&R	
● BAG C -----	11-17
Gear Differential	Waterfall
Transmission Assembly	Rear Upper Rod
Slipper Plate Set	Turnbuckle Assembly
Rear Shock Tower	
Rear Wing Seat	
Rear Gear Box	
● BAG D -----	18-27
Front & Rear Shock Assembly	ESC installation position
Front Shock Tower	Tires
Rear Shock Tower	
Front Suspension	
Rear Suspension	
Motor	
Gear Cover Plug	
Battery Plate	
Wing	
Body&Antenna Tube	
● SPARE PARTS & OPTIONAL PARTS -----	28
● SETUP SHEET -----	29

Items required to complete:

- Metric 1.5mm, 2.0mm hex tools
- Metric 5.5mm, 7.0mm Nut Driver
- 2 Channel Surface Radio System (Minimum)
- 1/10 ESC, Motor & Pinion Gear
- High Speed Servo
- 2S LiPo Shorty Battery & Compatible Lipo Charger
- Polycarbonate Paint for Bodies
- CA Adhesive
- Silicon gear diff oil



BEFORE INSTALLATION

- 1 Read through the instruction manual before installation in order to have an overview of what to do.
- 2 Check if there is any missing bags or defective parts, if there is, please contact our local dealer or our PR Distributor.
- 3 Symbols used throughout the instruction manual, comprises of:



Part bags used.



Assemble as many times as specified (here: twice).



Tighten securely.



Note the direction.



True-to-scale diagram.



Do not over tighten.



Must be purchased separately.



Apply threadlocker (screw cement)



Ensure smooth non-binding movement while assembling.



Assemble in the specified order.



Apply grease.



Cut Below The Line



Assemble left and right sides the same way.



Apply oil.

- 4 This kit contains screws and hardware in different metric sizes and shapes. Before using them, check the screws on the true-to-scale diagrams on the left side in each assembly step. Some screw are extras.

TOOLS REQUIRED

CAUTION: Handle tools carefully!

- Needle Nose Pliers

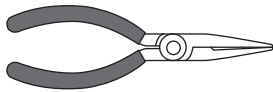

- Awl

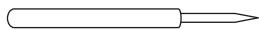

- Grease



- Screw Cement



- Round Cutter & Sander

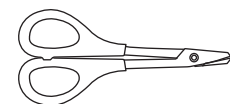

- Sharp Hobby Knife

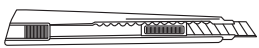

- Wire Cutters



For trimming bodies Cutting along curved lines was never so easy!

- Hex Wrench

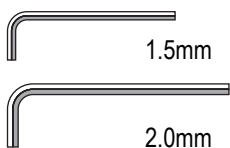

- Silicone Shock Oil



- SP Knife Edge Reamer



- CA

- Cross Wrench

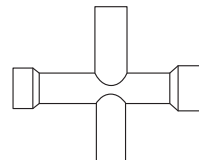

- Do not pre-drill as precise drilling of 1mm to 15mm holes can be performed after body shell painted.

- 5mm-5.5mm-7.0mm

RADIO PREPARATION

- A new battery must be charged before it is used. Refer to the charger instruction manual for charging.
- Set up the radio control system as indicated below.

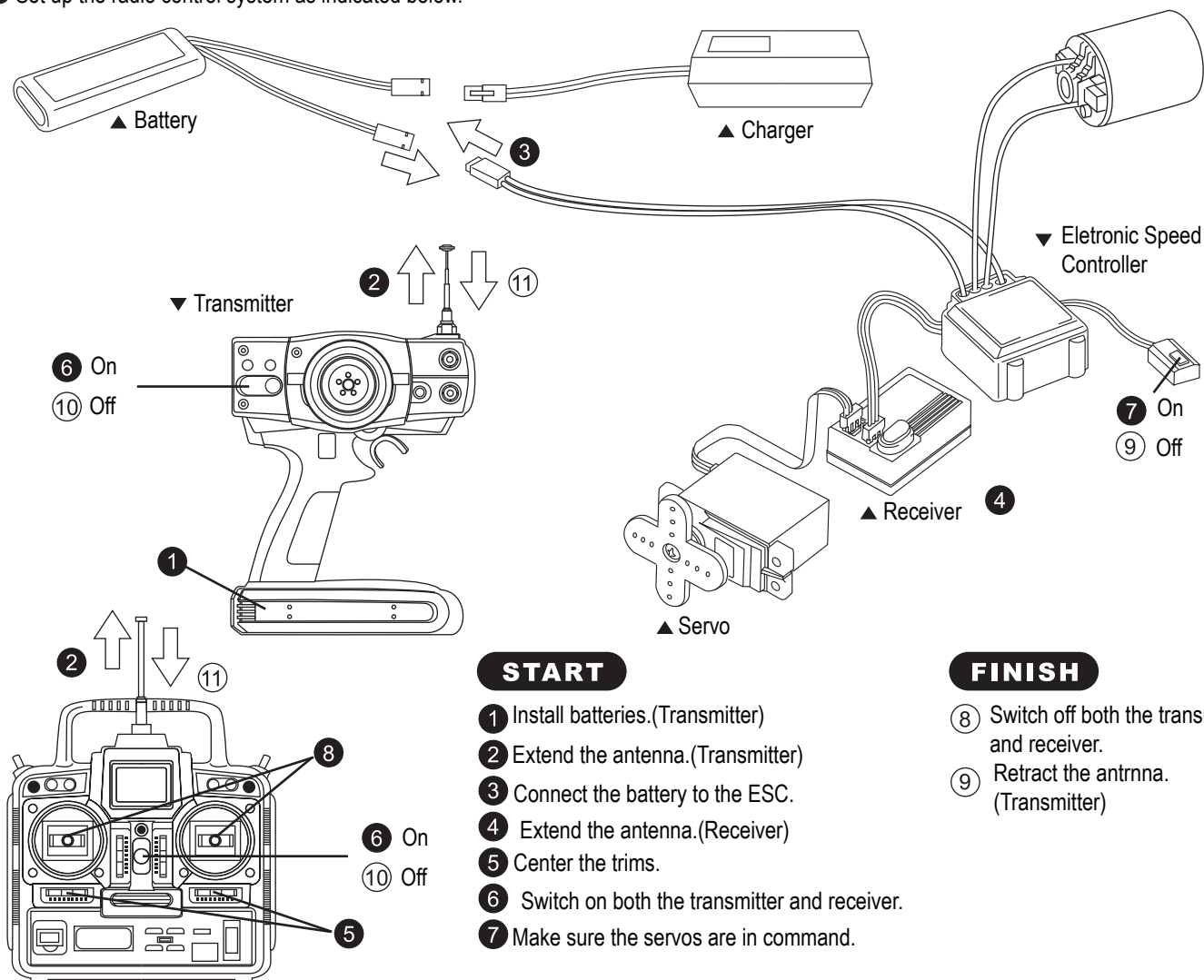

*When using a 2.4GHz transceiver, steps ②, ④ and ⑨ are not required.

A1-Chassis Guard Installation

BAG
A

4
82400016 M3x6mm

4
82400026 M3x8mm

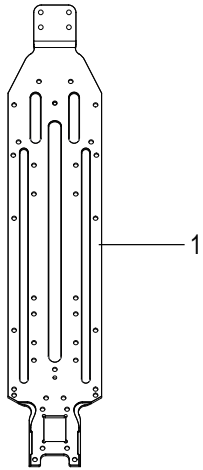

66400576
Alu Chassis

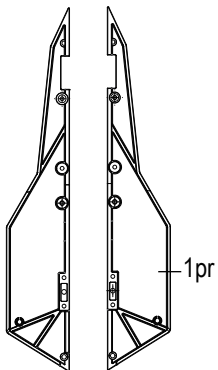

66400076

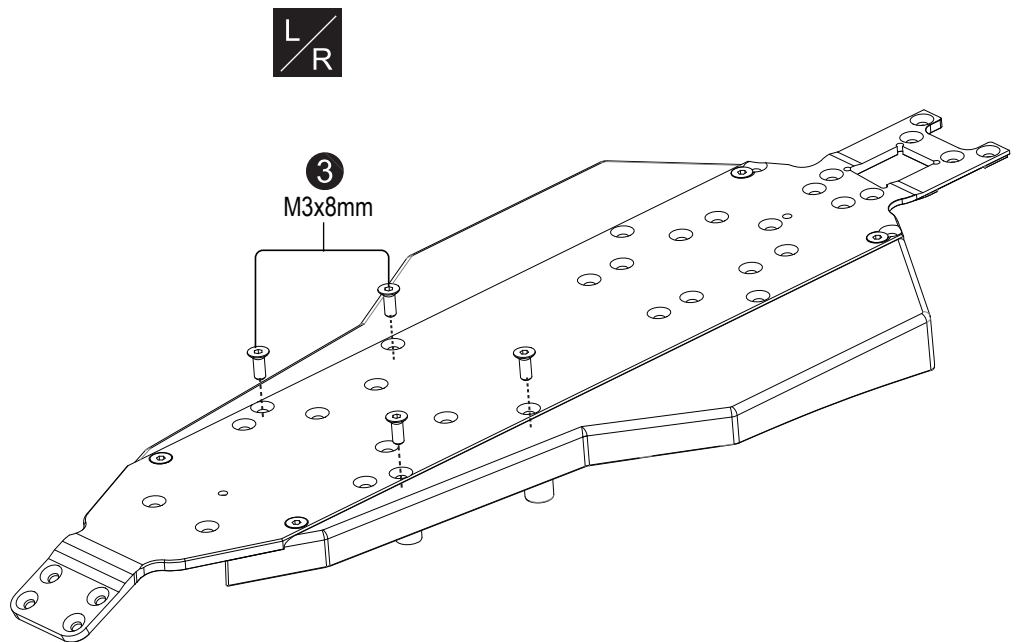
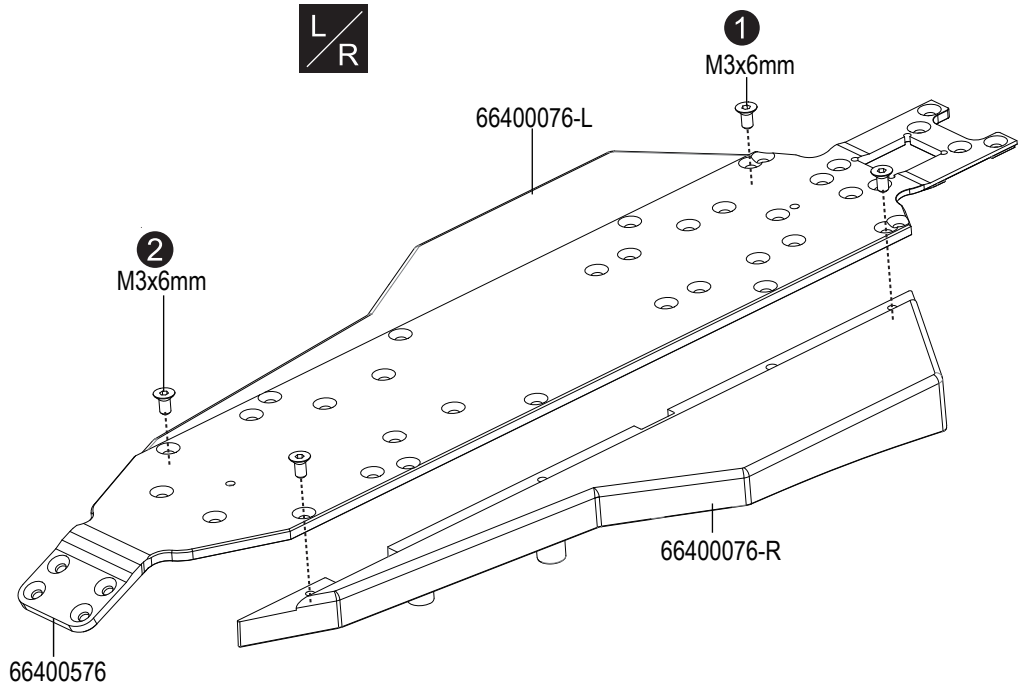



A2-Steering Bellcranks

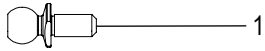

68430086 M4.8x6mm(-0.8mm)

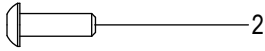

80400046
M3x10mm

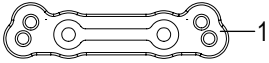

66000020-2
Ackerman Plate

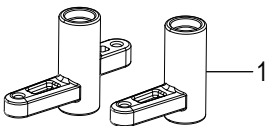

68480036
Steering Linkage

Do not over tighten.

Do not over-tighten this screw. They should be /tight but still allow the parts to move freely

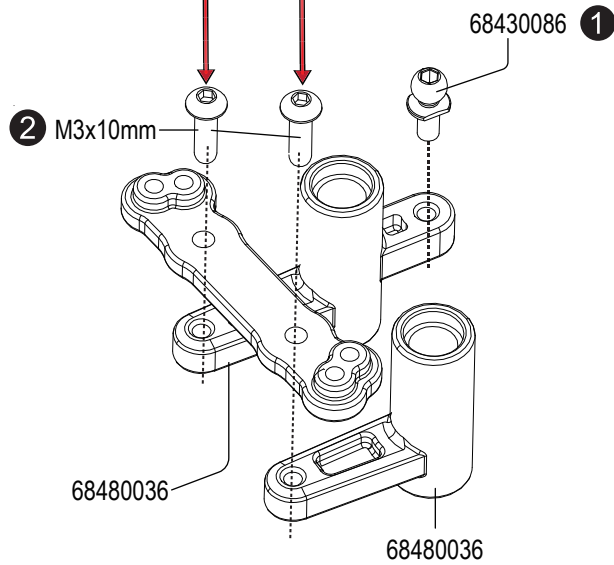

A3-Steering Bellcranks

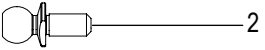

68430086 M4.8x6mm(-0.8mm)



66400756
5x8x2.5mm Bearin

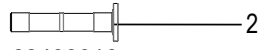

68400016
Alu

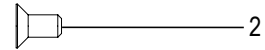



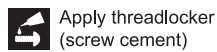
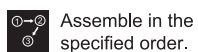
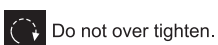
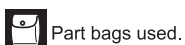
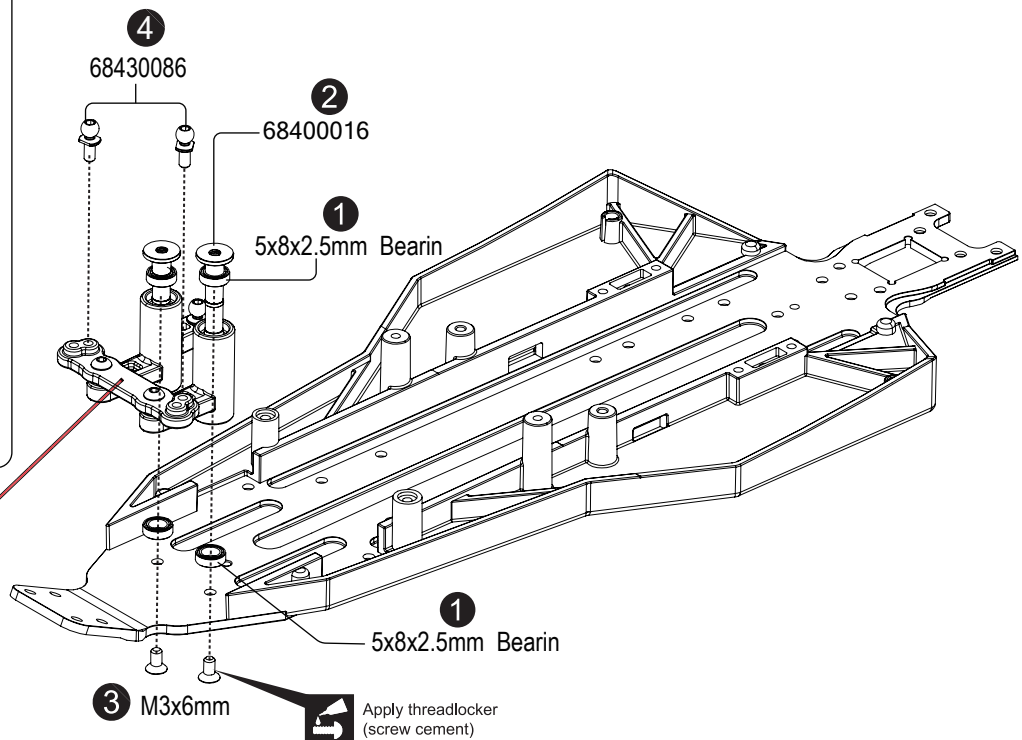
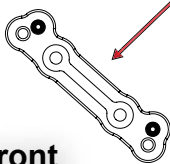



82400016 M3x6mm



PR S1 RM

BAG
A

A4-Steering Servo

-  1
87400096
M3x8mm Set Screw
-  1
68430086
M4.8x6mm(-0.8mm)
-  1
82400106 M3x10mm
-  1
83400106 M3 Nut
-  1
66400036
Servo horns
-  2
66400066
Rod End

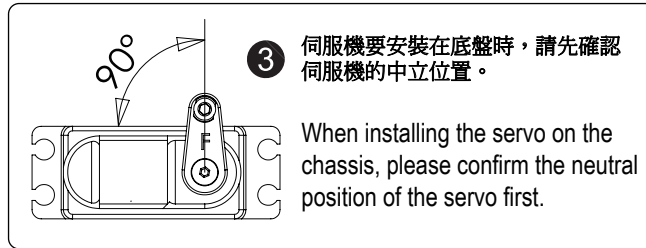
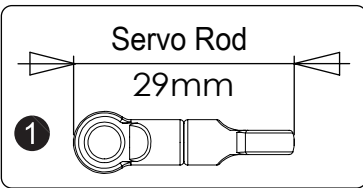
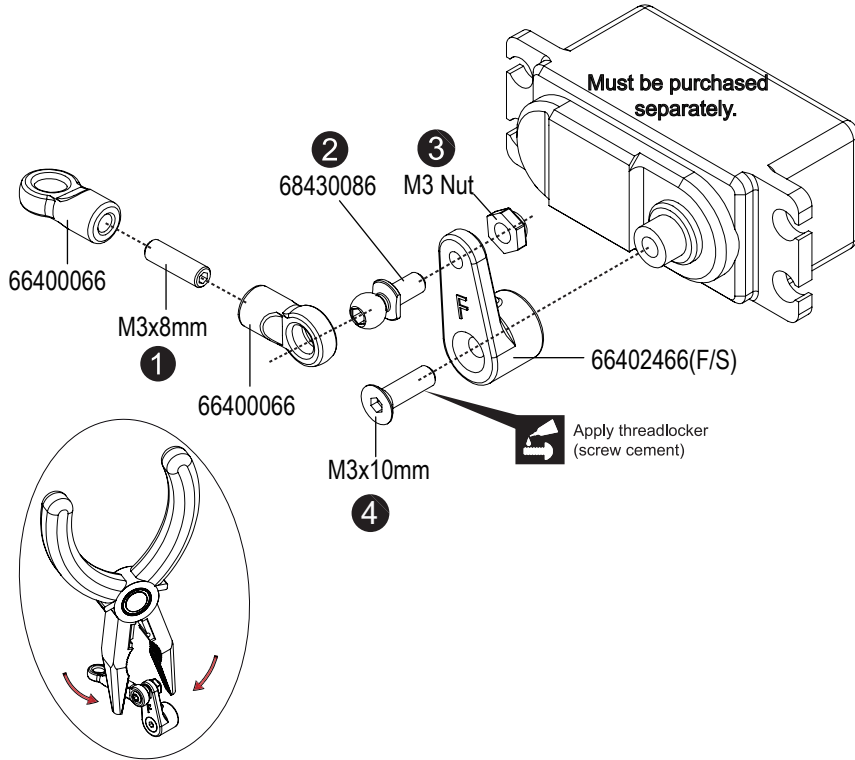

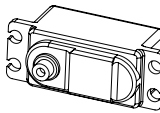

Suggestion



Low Profile Servo

BAG
A

A5-Steering Servo

-  4
80400036
M3x8mm
-  4
85000010
Shim3x8x0.5mm
-  2
66400116
Servo Mount

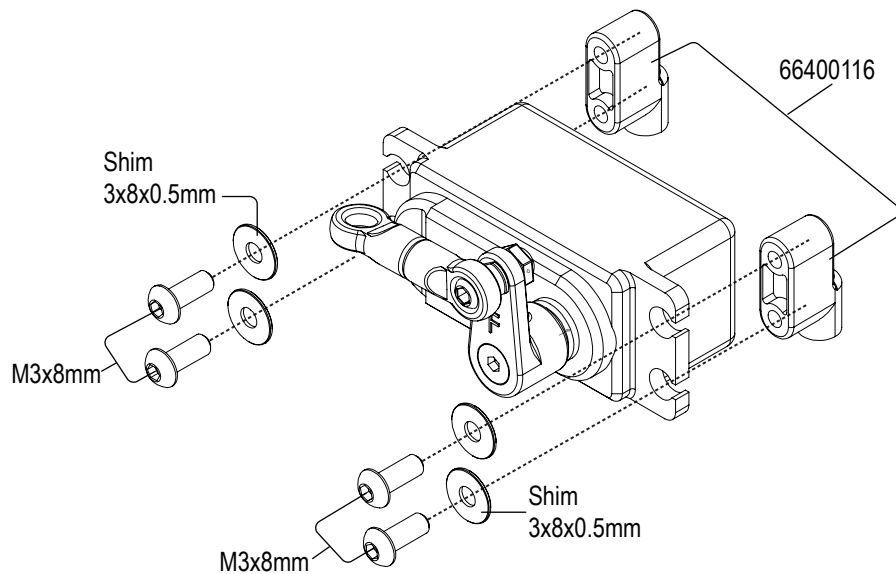

BAG
A

A6-Steering Servo

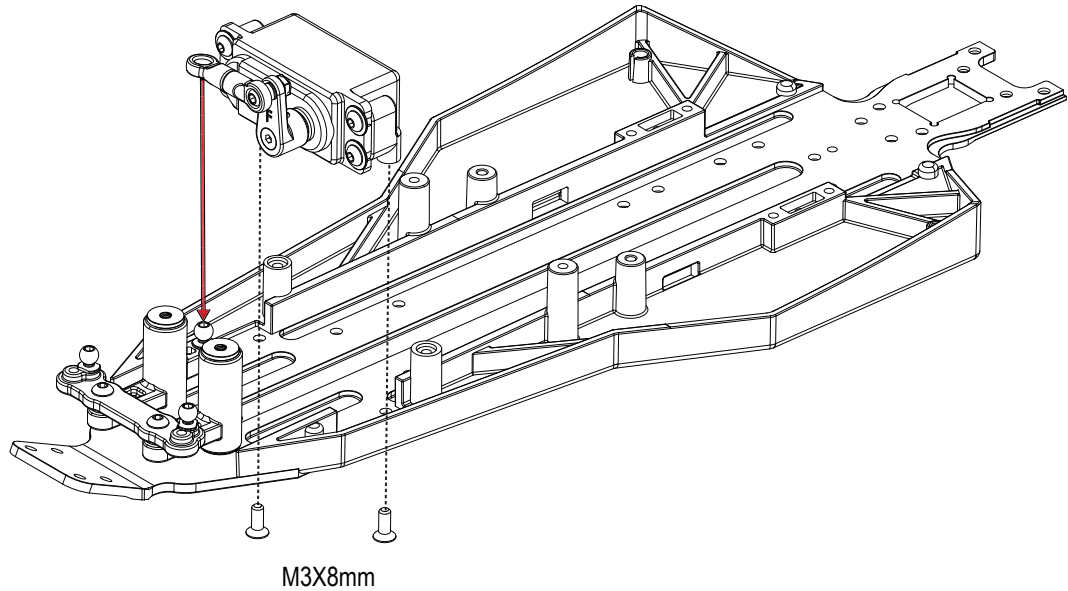
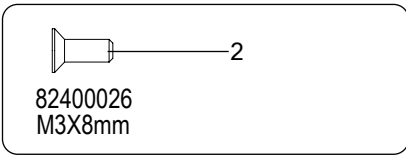

BAG
B

B1-Front Wishbone

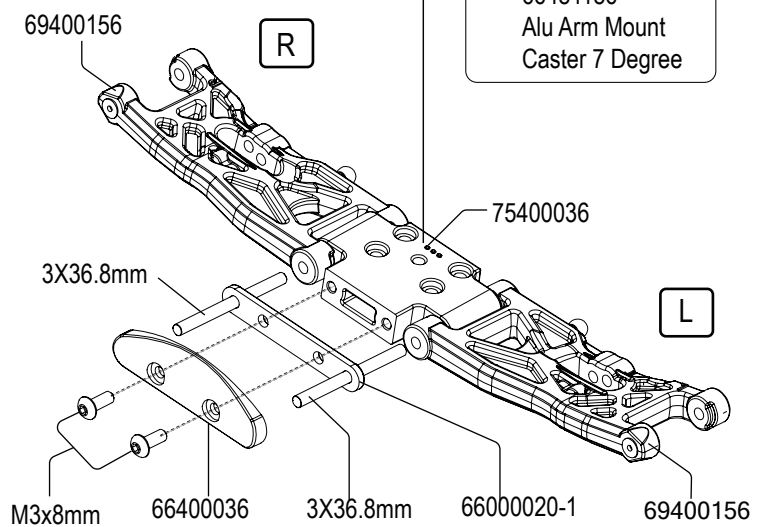
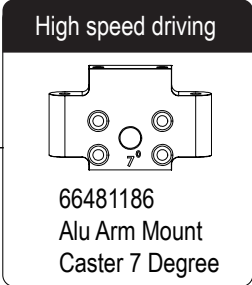
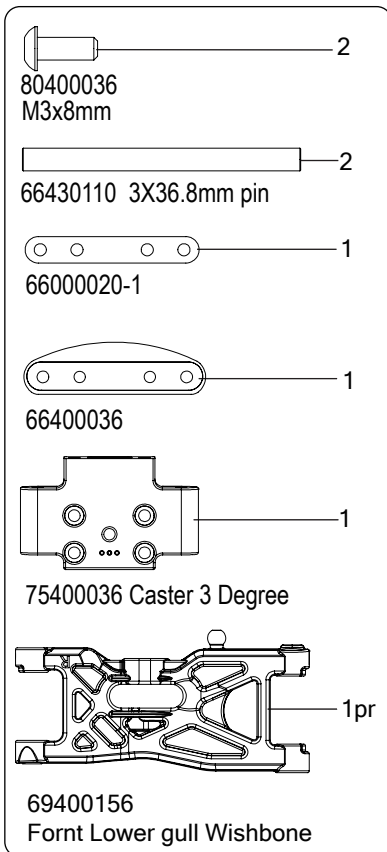

PR S1 RM

BAG
B

B2-Front Spindle (L&R) Side

Corner Speed

4
80400186
M2.5x6mm

2
80400036
M3x8mm

2
68430086
M4.8mmx6mm
Lower 0.8mm

2
68430076
M4.8x10mm

2
83400026-M3 Lock Nut

4
66401686
Steering Screw Stepped

4
89430010
5x10x4mm Ball Bearing

4
85440180 Shim 5x8x0.5mm

2
66481337
Carbon Fibre Steering Plates

2
71400699-Front Wheel Hub Axle

1pr
66480856-Steering Block

1pr
66401876-Caster Block 3 degrees

2
68410066
Plastic 4mm

L/R Assemble left and right sides the same way.

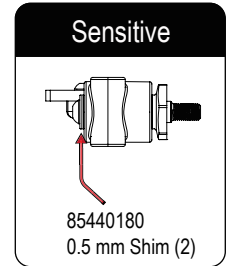
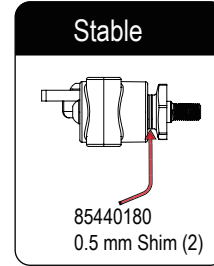
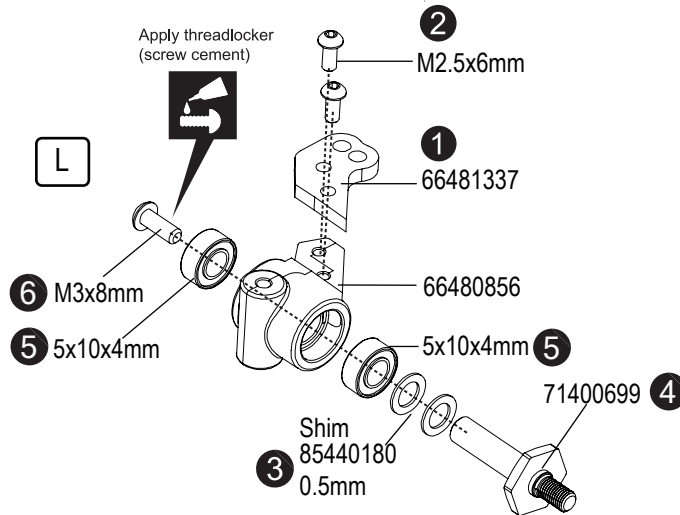

L

Do not over-tighten this screw. They should be /tight but still allow the parts to move freely

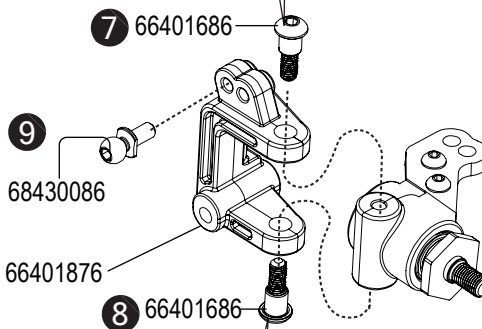

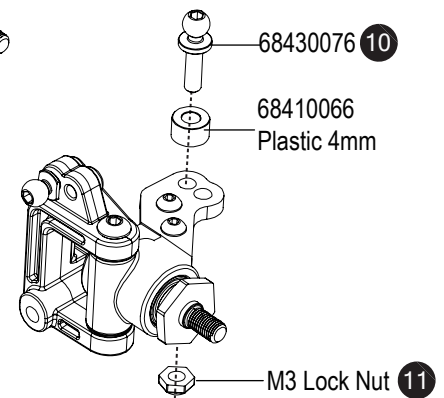
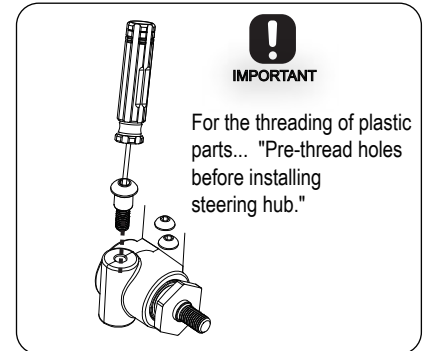

Do not over-tighten this screw. They should be /tight but still allow the parts to move freely

L/R Assemble left and right sides the same way.

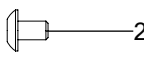

B3-Front Suspension(L&R)

BAG
B

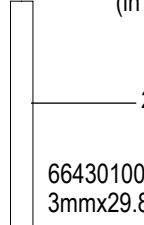
-  2
80400016
M2.6x4mm
-  2
69400156 2.0mm
(in B1)
-  2
66430100
3mmx29.8mm Pin

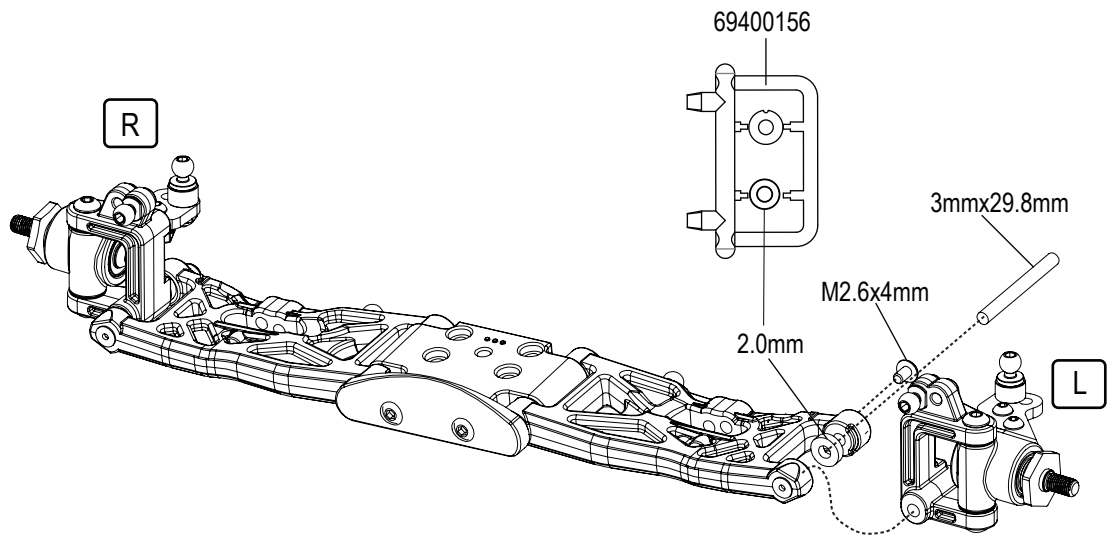

BAG
B

B4-Front Shock Stay



IMPORTANT

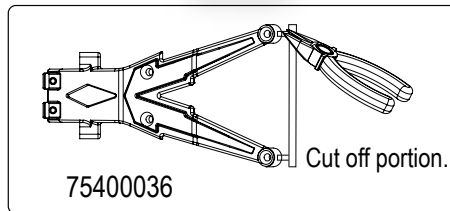

IMPORTANT

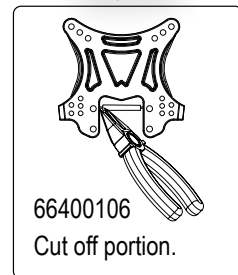

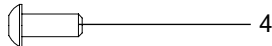
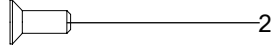
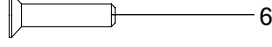
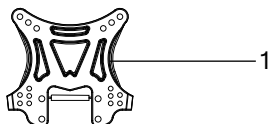
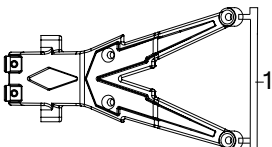
-  4
80400046 M3x10mm
-  2
80400036 M3x8mm
-  6
82400046 M3x14mm
-  1
66400106
Front & Rear Shock Tower
-  1
75400036
Front Chassis Top Plate

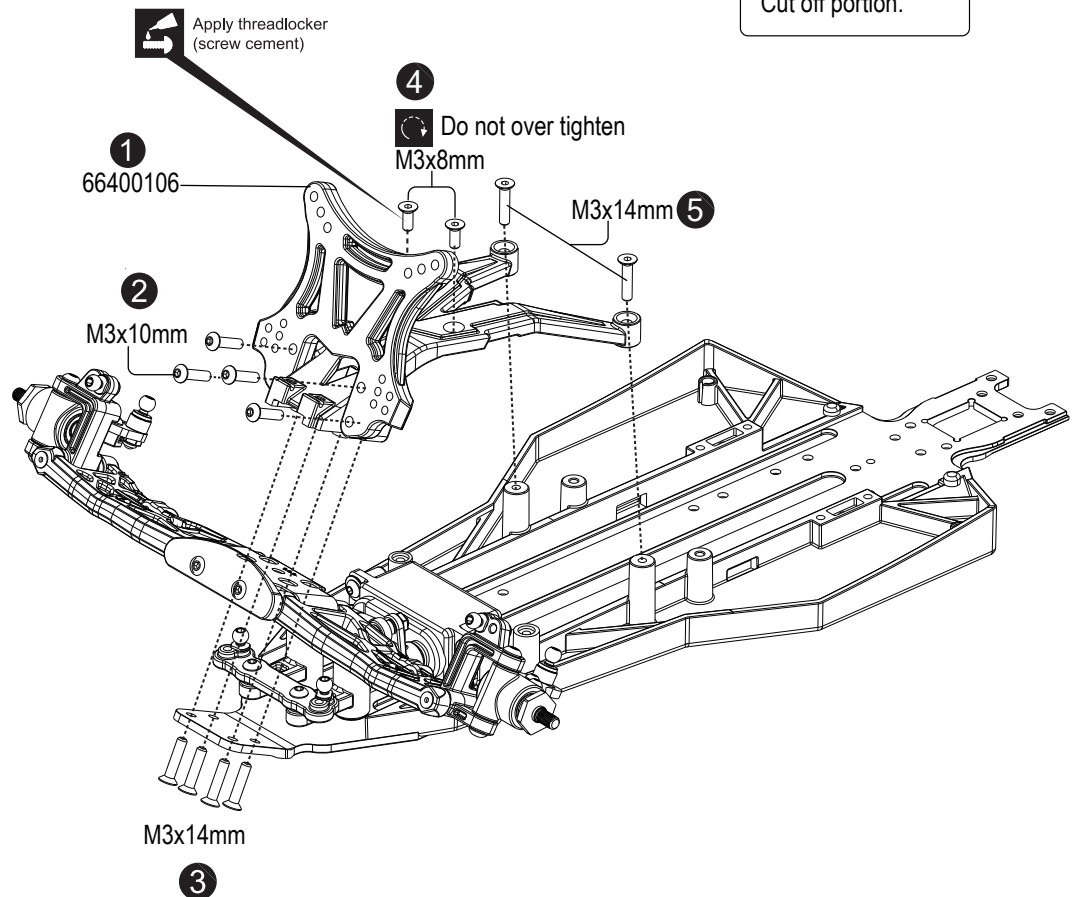

PR S1 RM

BAG B

B5-Front Upper Turnbuckle Assembly

L/R Assemble left and right sides the same way.

One side is reverse threaded.

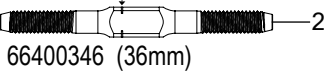

Note the direction

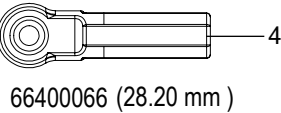

66400066 (28.20 mm)

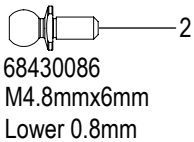

68430086
M4.8mmx6mm
Lower 0.8mm

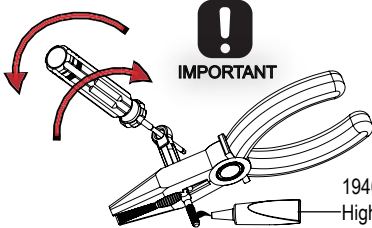
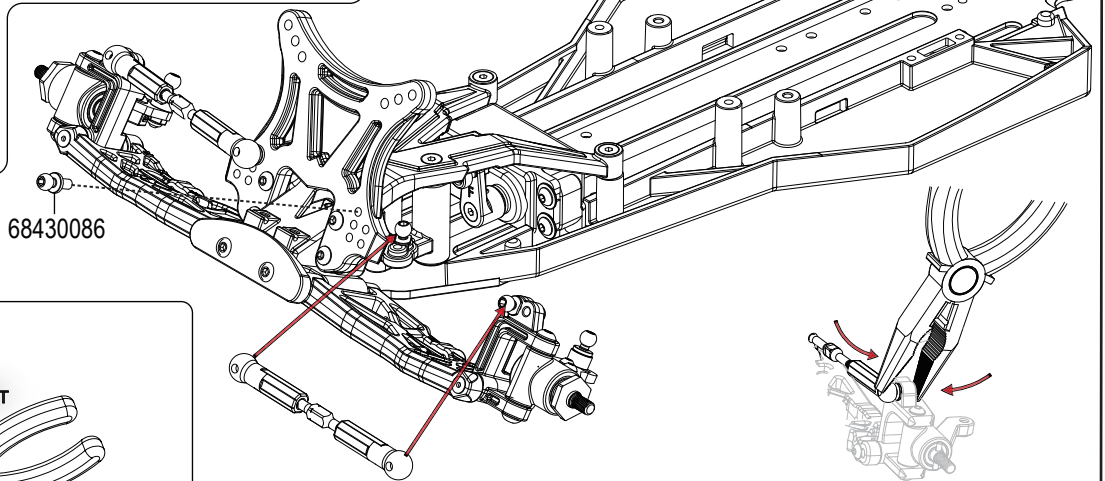

! IMPORTANT

19460016
High Pressure
Grease

Thread and unthread the turnbuckle into the plastic rod end a few times to allow easier adjustment after assembly.

1:1

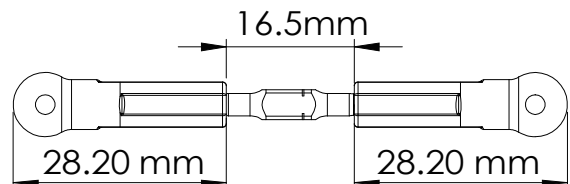

BAG B

B6-Turnbuckle Assembly-Steering Rod

One side is reverse threaded.

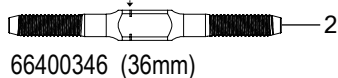

66400346 (36mm)

Note the direction



66400066
(31.3 mm)



66400066
(31.3 mm)

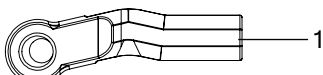

66400066 (31.3 mm)

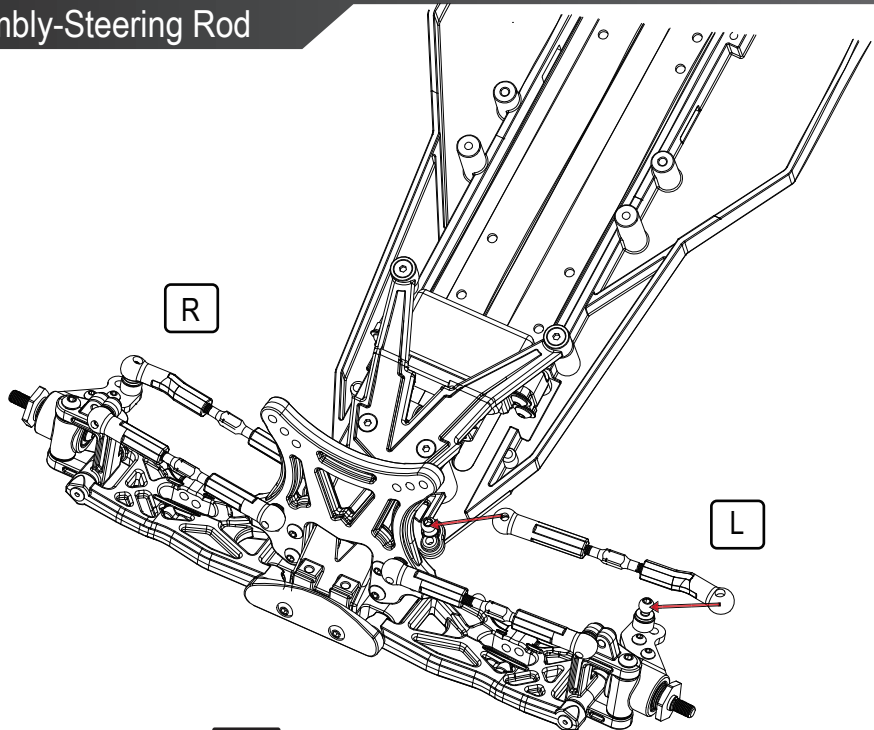

1:1

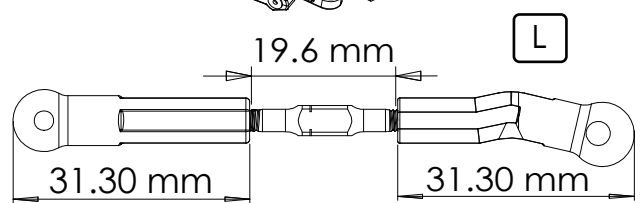
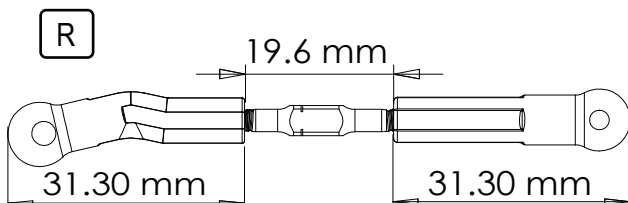

B7-Rear Hub & CVA L&R

BAG
B

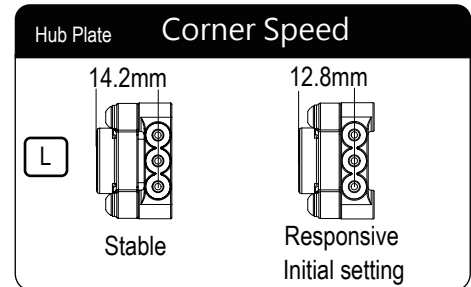
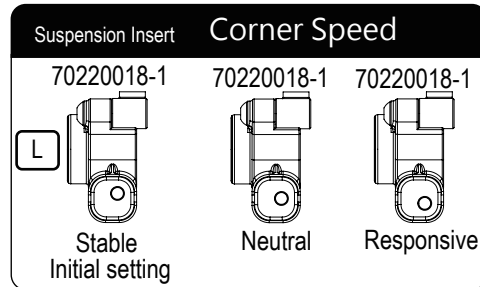
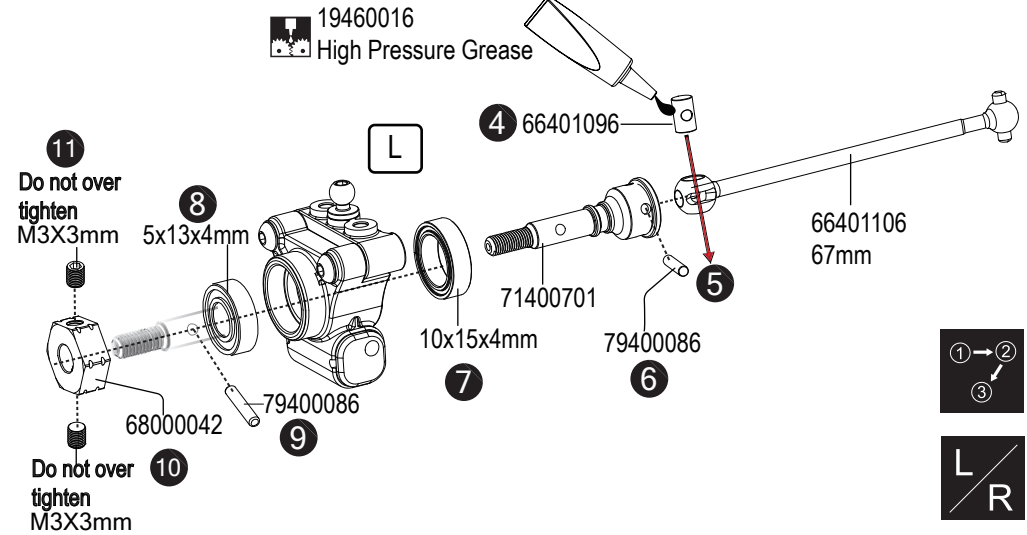
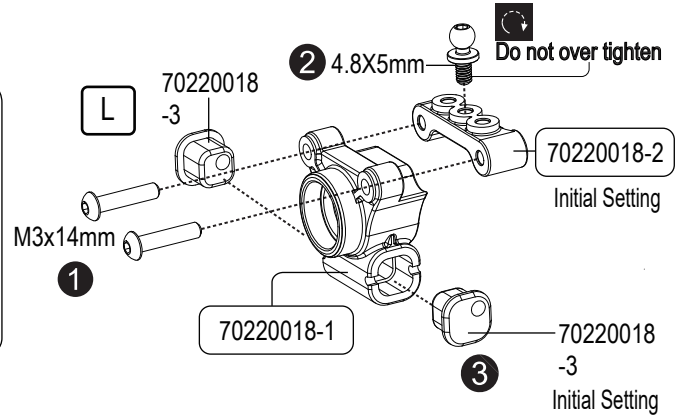
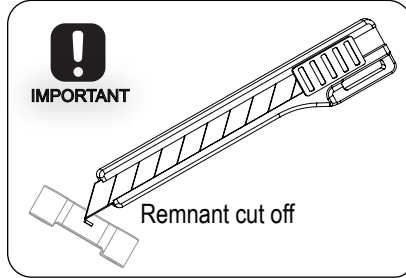
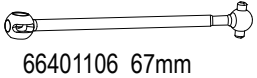
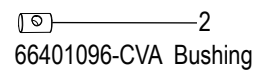
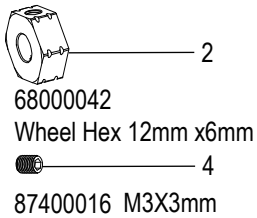
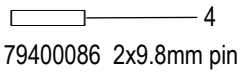
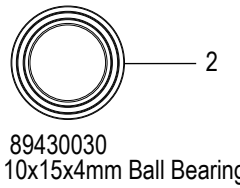
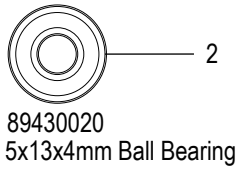
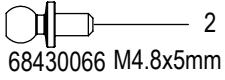
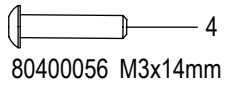

B8-Rear Hub (L&R)

BAG
B

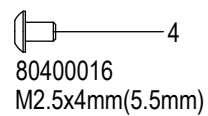
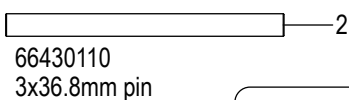
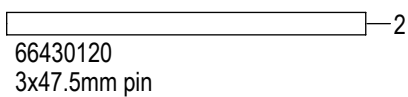

Front

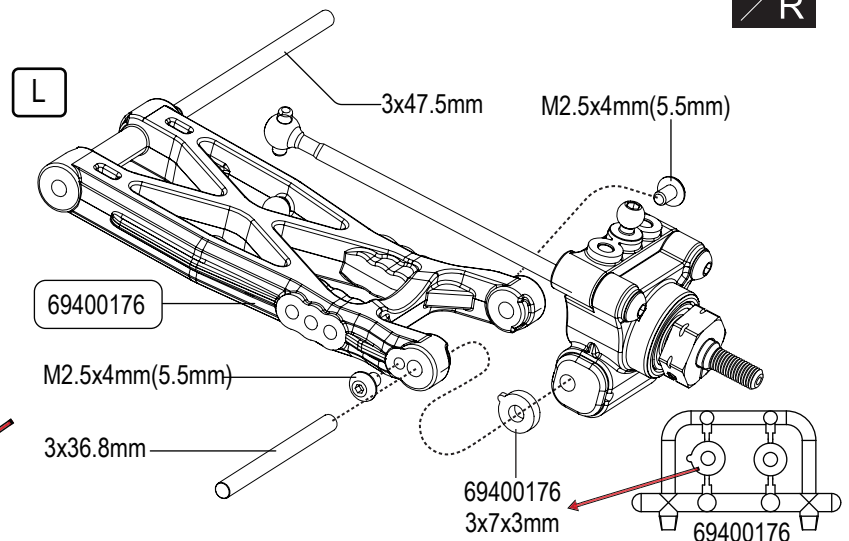

Part bags used.

Assemble left and right sides the same way.

Do not over tighten.

Assemble in the specified order.

Apply grease.

PR S1 RM

BAG
B

B9-Rear Suspension

Please add it or not according to the loose-tight.
依據鬆緊，請加它或不加它

- 4
82400026
M3x8mm
- 2
82400156
M3x22mm
- 1
66000020-4/RF
- 1
66000020-3/RR
- 2
85440320
Shim 3x8x0.15mm
- 4
68410066
3x5.5mm Pivot Bal

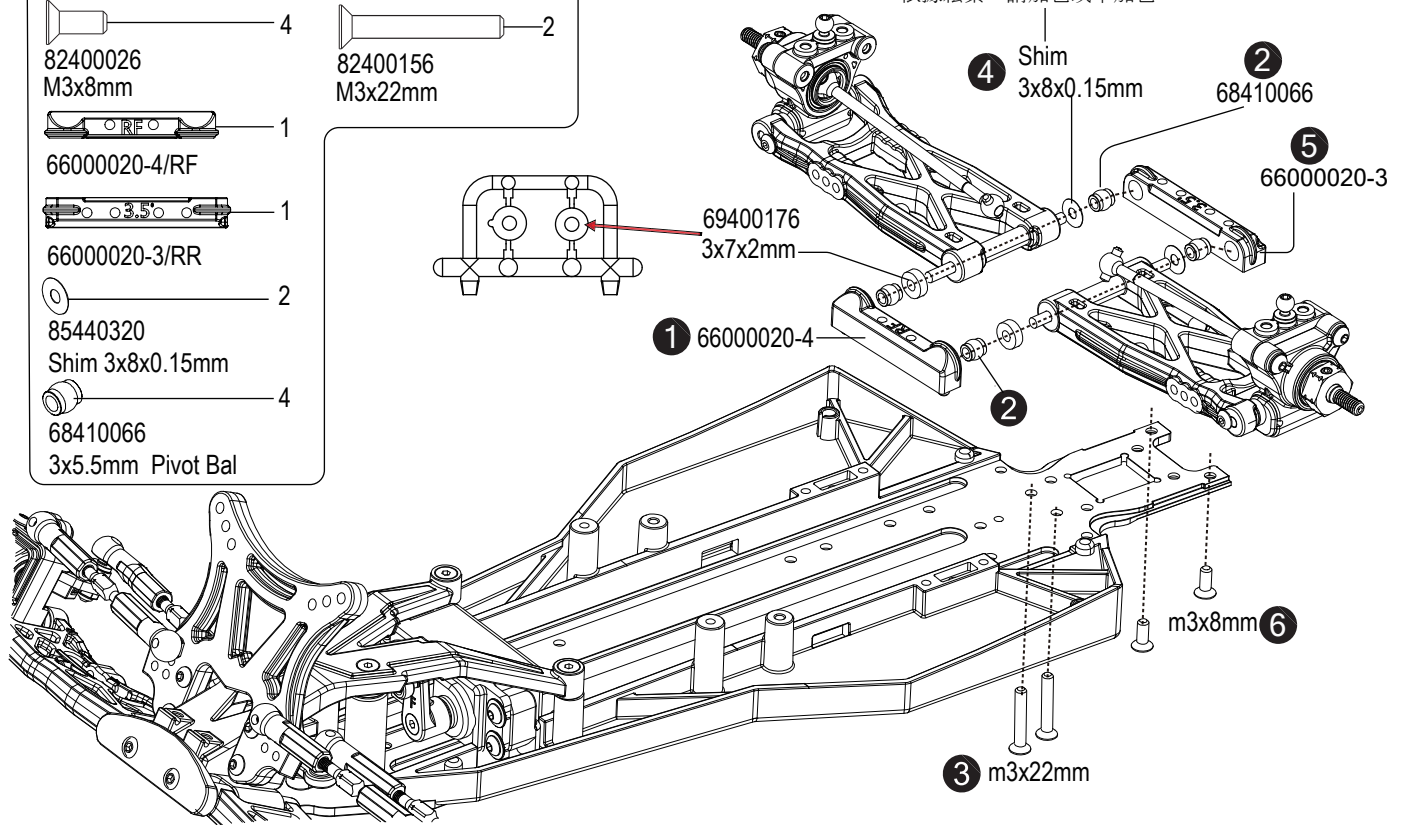

BAG
C

C1-Gear Differential

- 4
80000021
M2.5x8mm
- 2
85440170
5x8x0.8mm Shim
- 2
85440160
4x10x0.15mm Shim
- 2
(o-ring)
31450016
- 2
85400016
3.5 E Buckle
- 1
74480037
- 1
66480366

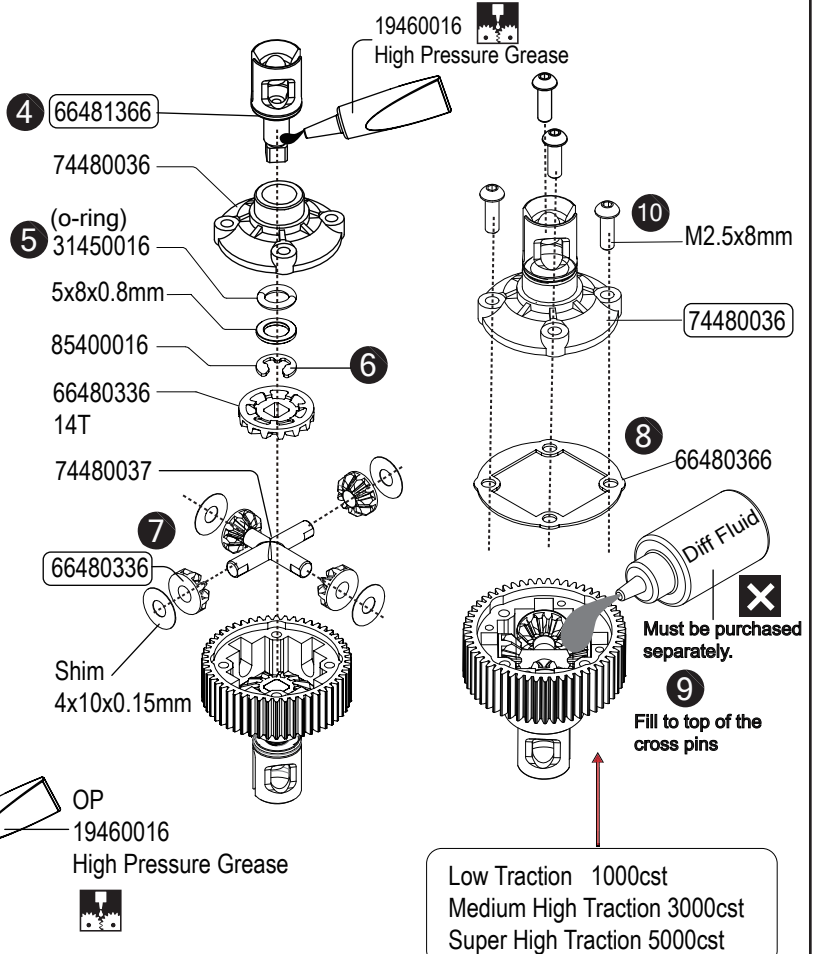
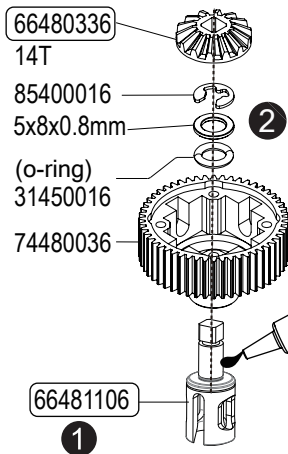
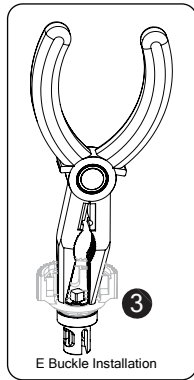

Part bags used.



Apply grease.



Assemble in the specified order.



Must be purchased separately.



C2-Transmission Assembly

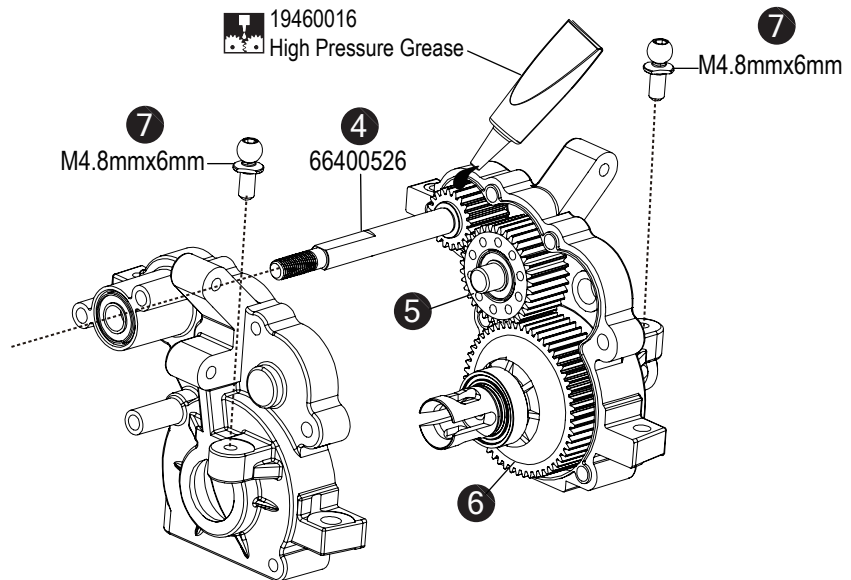
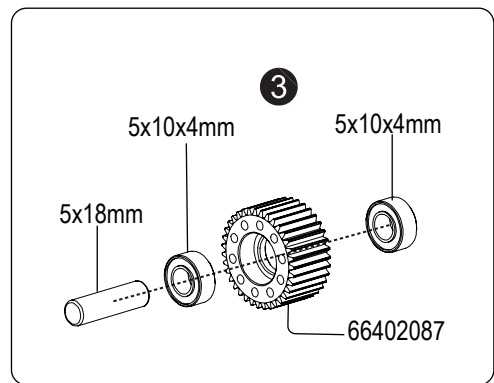
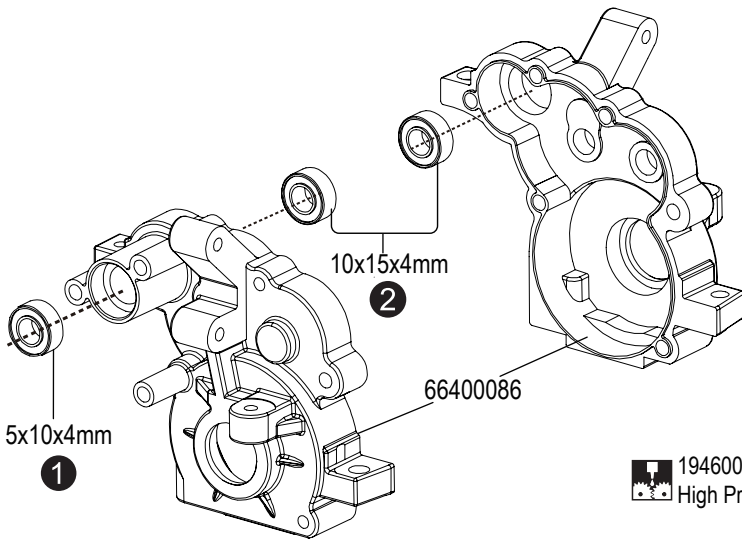
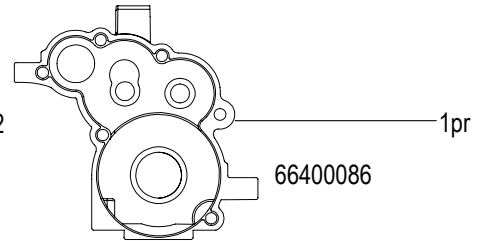
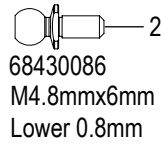
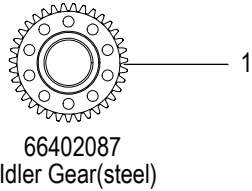
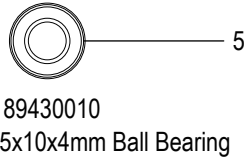
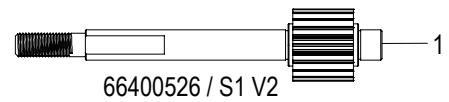
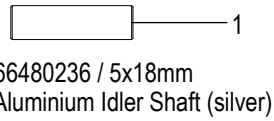
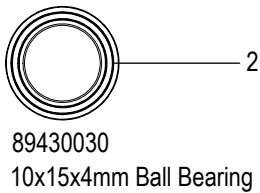

Option Parts

66402687 S1 V4 Ball Diff
Outdrive Set +1.3mm

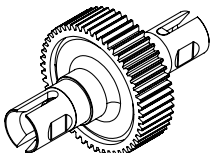

Option Parts

66402086 Aluminium
Idler Gear

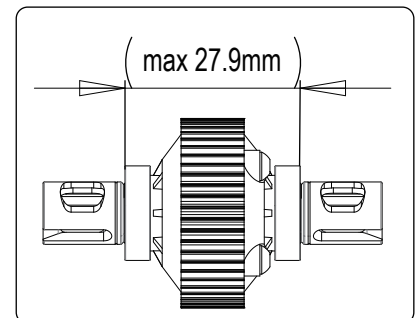
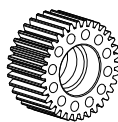

PR S1 RM

C3-Transmission Assembly



80400056
M3X14mm

80400066
M3X20mm

80400086
M3X32mm

80400096
M3X36mm

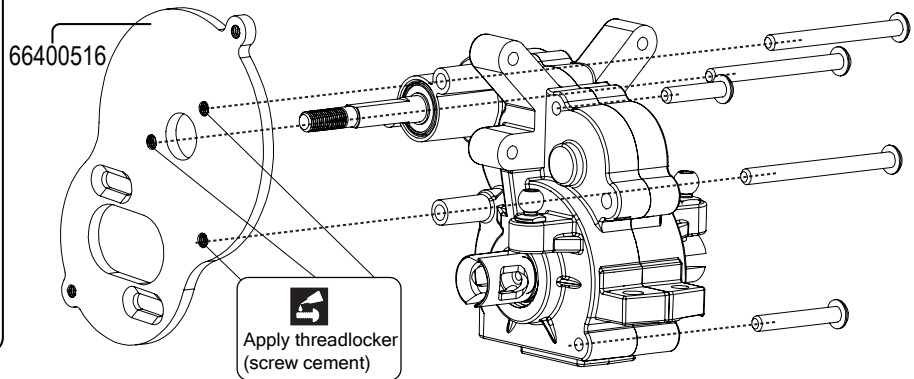
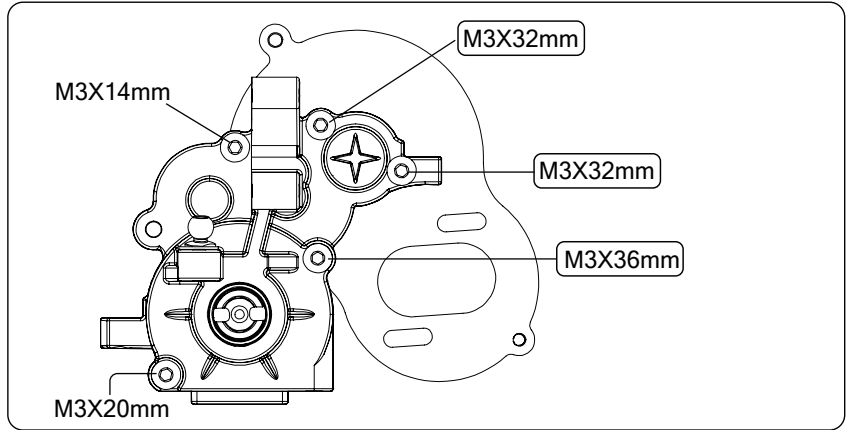
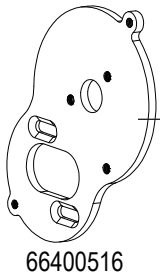

C4- Slipper Plate Set

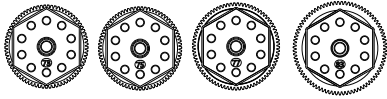

66480576-73T 66480596-77T
66480586-75T 66480606 83T

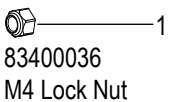
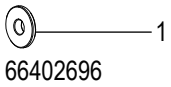
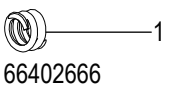
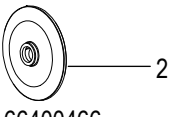
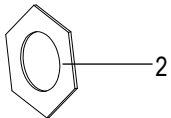

Assembly Video

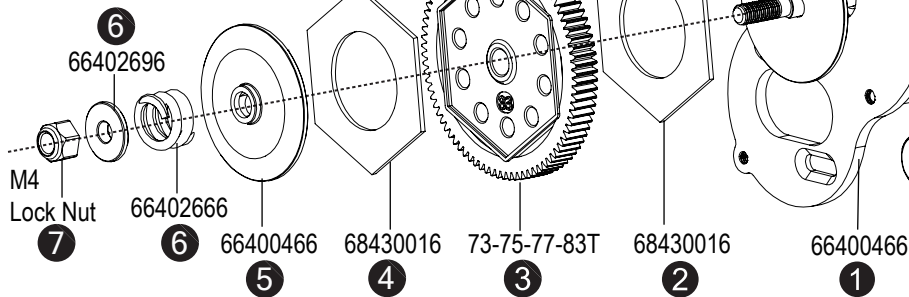

Tighten the lock nut for the slipper spring to 0mm for first drive. Adjust according to track conditions and motor turn.

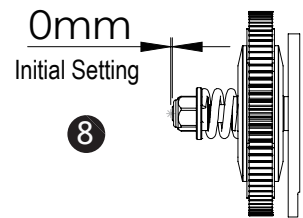

C5-Rear Shock Tower

BAG
C

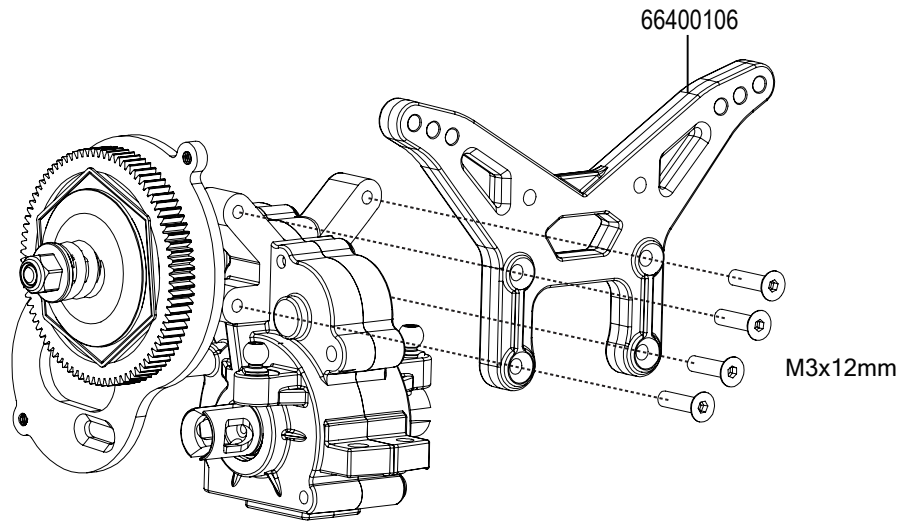
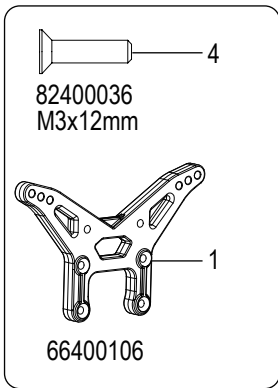

C6-Rear Wing Seat

BAG
C

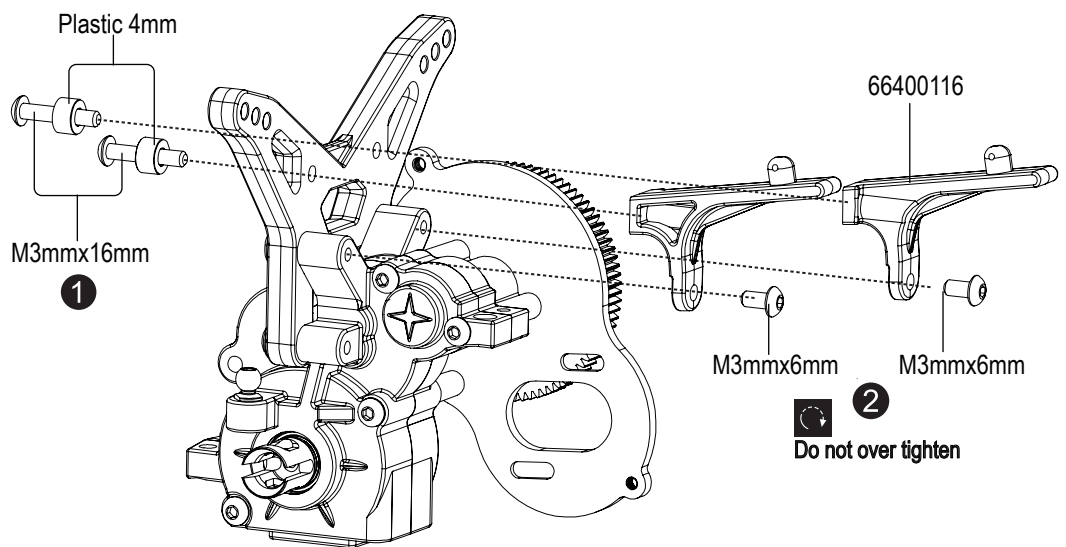
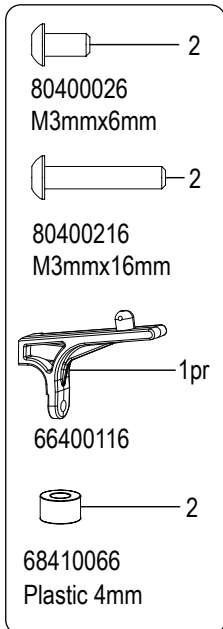

PR S1 RM

BAG
C

C7-Rear Gear Box

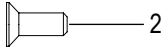

82400026
M3x8mm

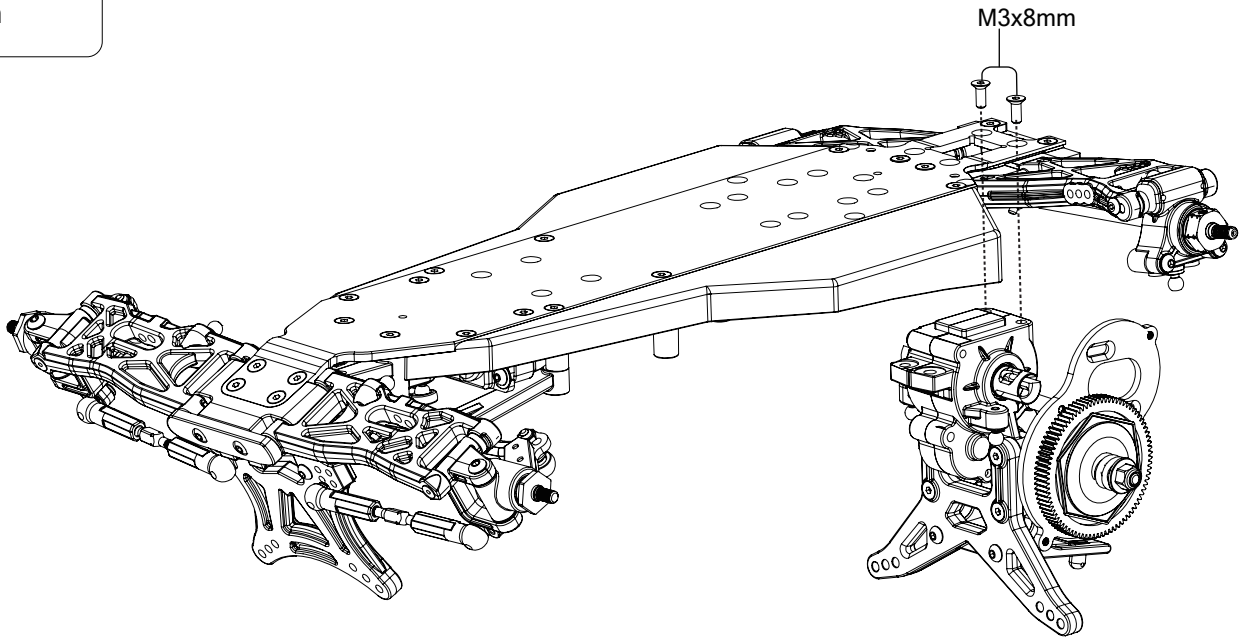

BAG
C

C8-Rear Gear Box

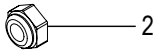

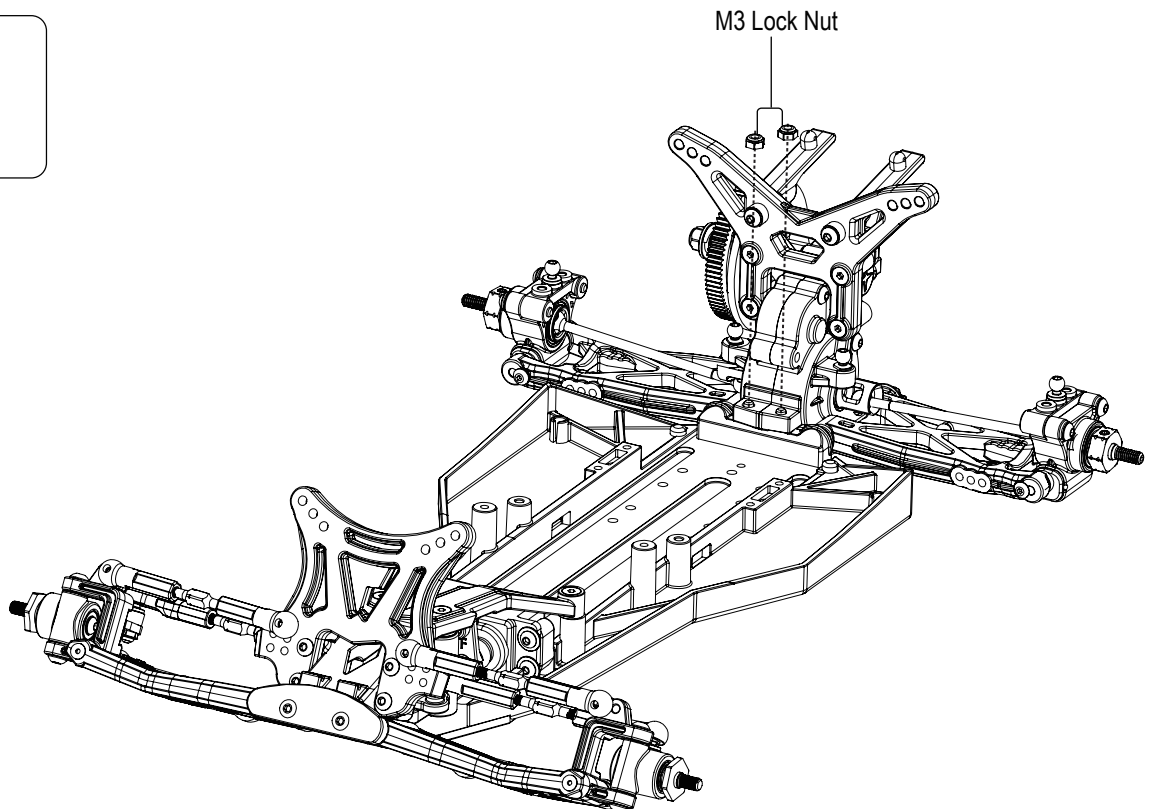

83400026
M3 Lock Nut





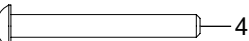
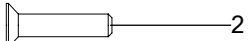
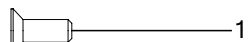

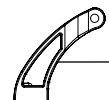
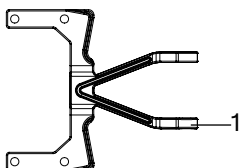
C9- Waterfall

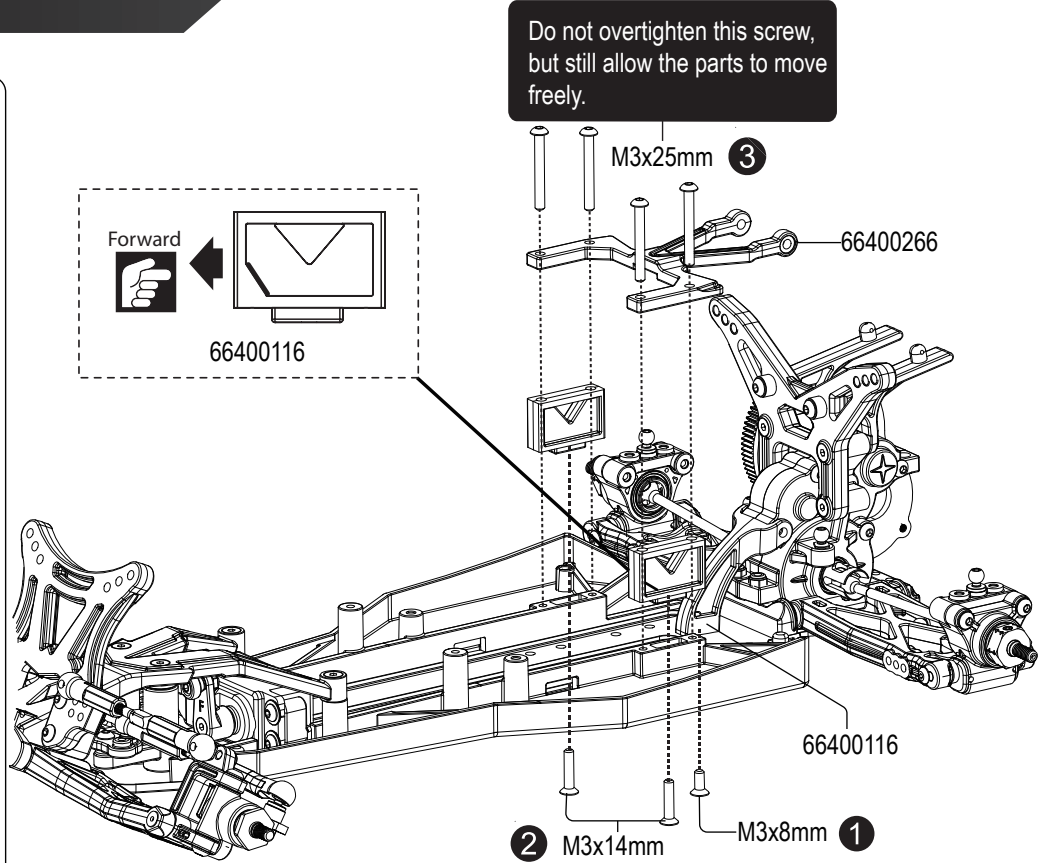
-  4
80400076 M3x25mm
-  2
82400046 M3x14mm
-  1
82400026 M3x8mm
-  1pr
66400116
-  Note the direction.
-  1
66400116
-  1
66400266



C10- Waterfall

-  1
83400026
M3 Lock Nut
-  1
80400086
M3x32mm

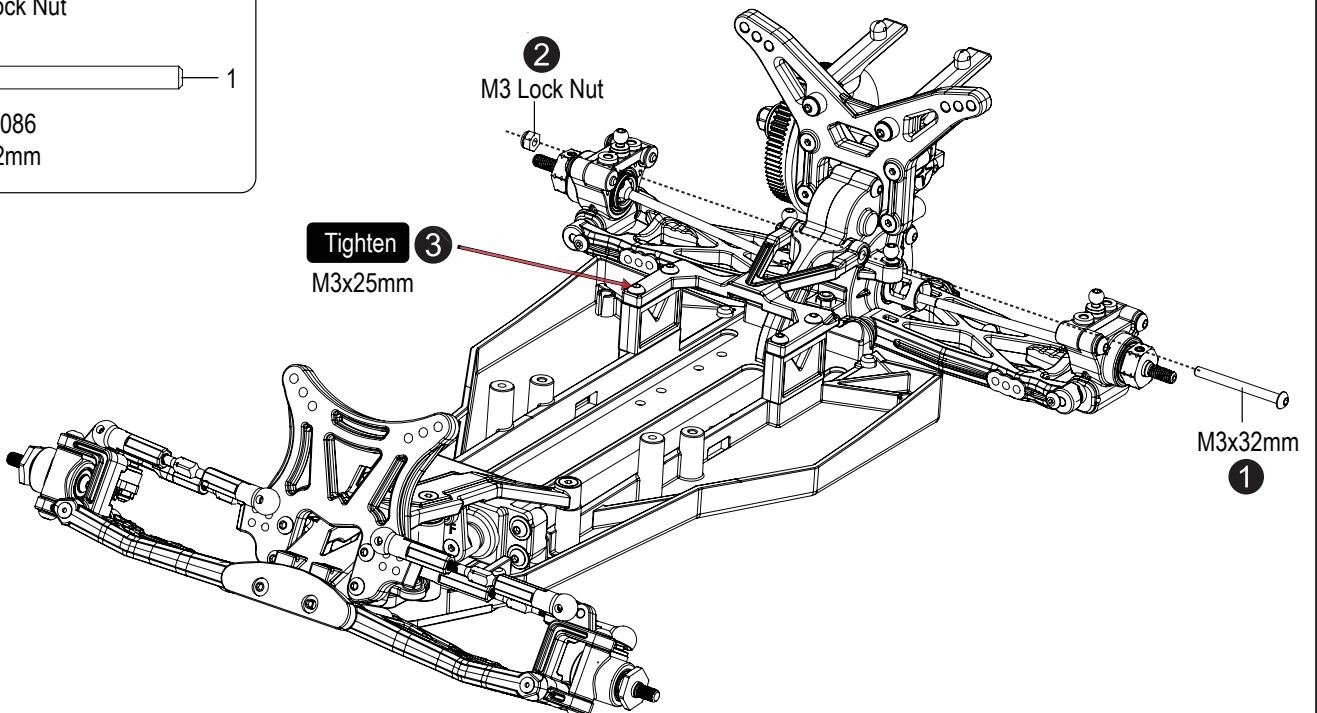

C11-Rear Upper Rod-Turnbuckle Assembly

One side is reverse threaded.

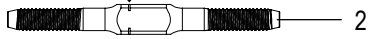

66400346
36mm

Note the direction.

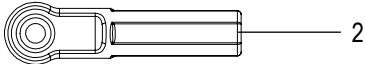

66400066
31.3mm

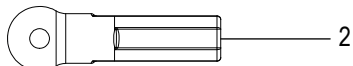

66400066
28.2mm

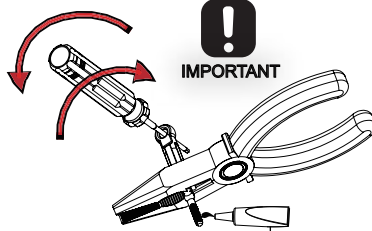

19460016
High Pressure Grease

Thread and unthread the turnbuckle into the plastic rod end a few times to allow easier adjustment after assembly.

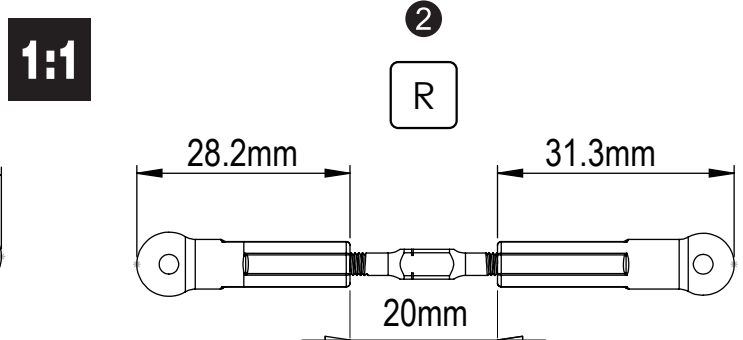
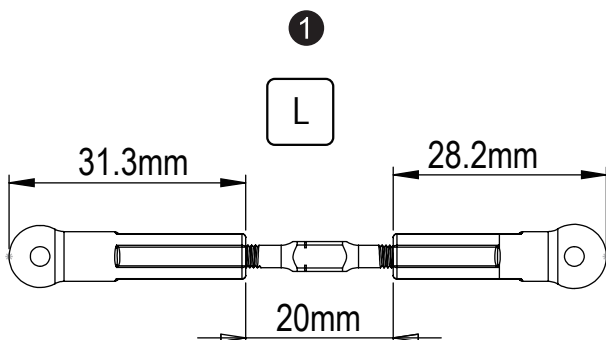
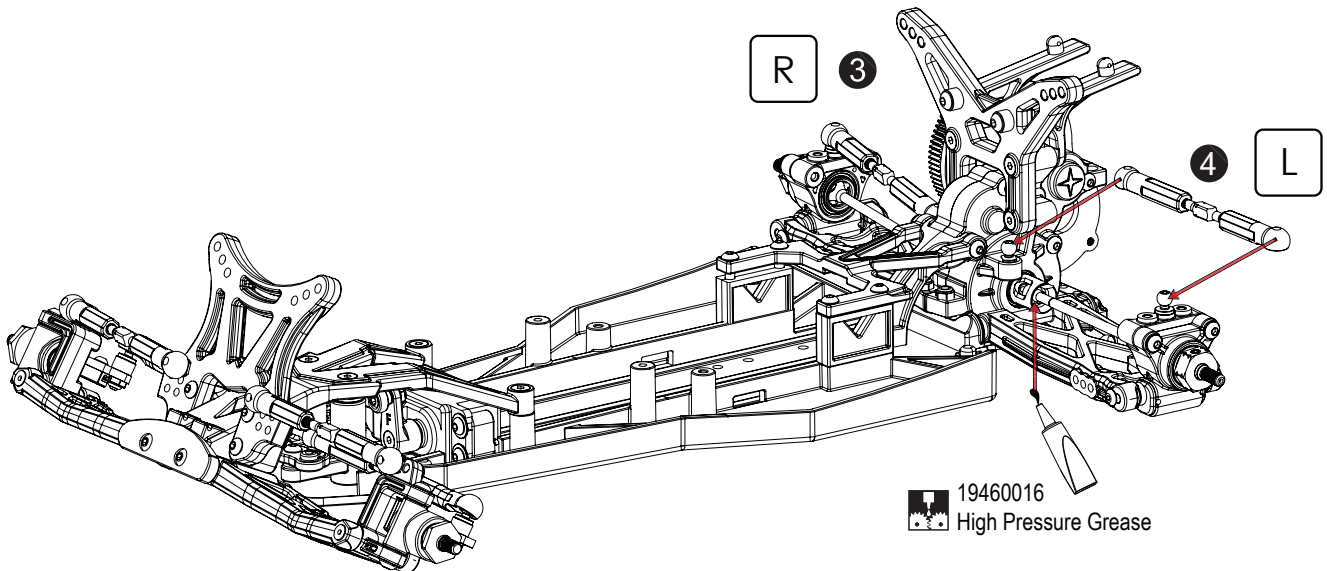
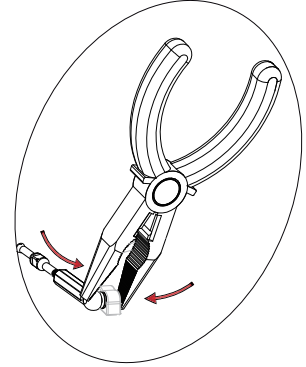

1:1



D1.1 Front & Rear Shock Assembly

BAG
D

!
IMPORTANT

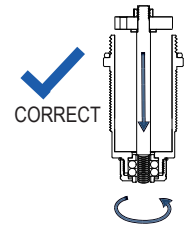
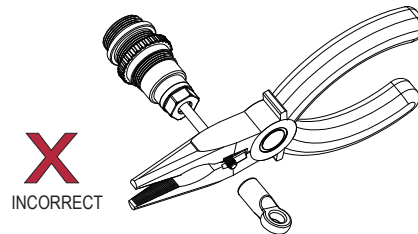
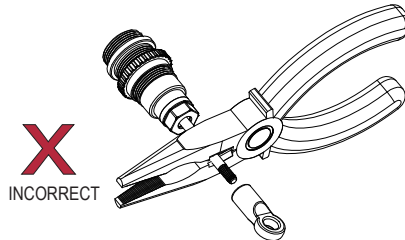
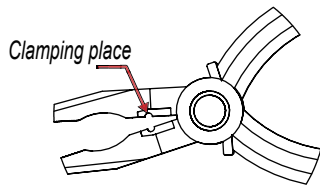
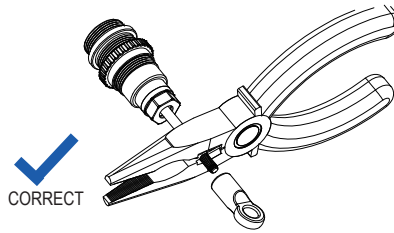

Twist the shock rod through the lower shock body assembly.

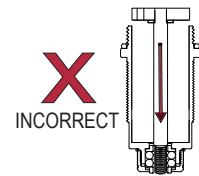

EXTREMELY IMPORTANT



Front Buildx2
Rear Buildx2
Initial setting

68410066

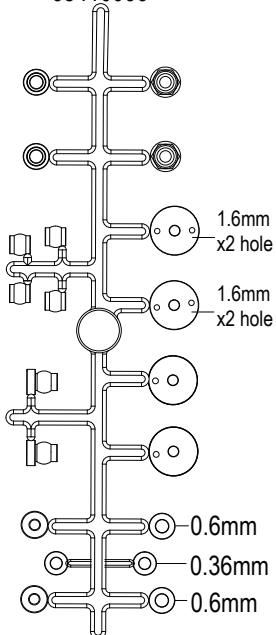

m2.5 Do not over tighten (screw cement)

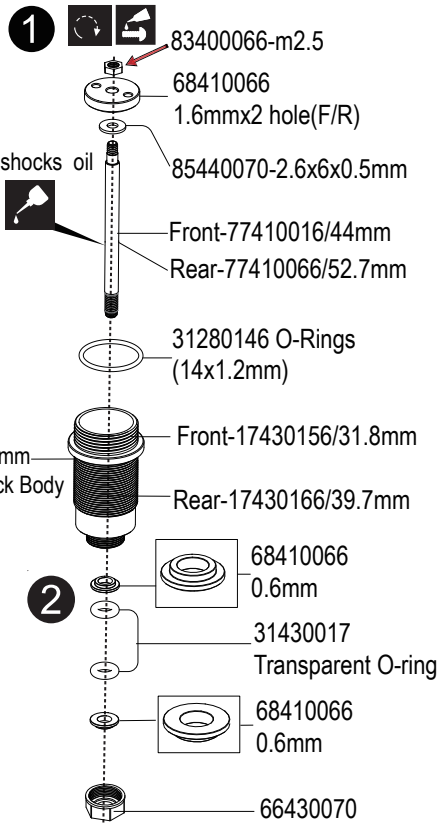

3



68410066
Downstop Shims
Front-0.36mmx2pcs
Rear-0mm

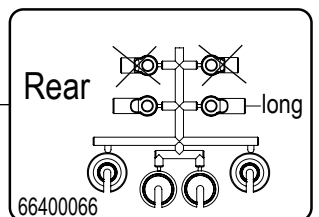
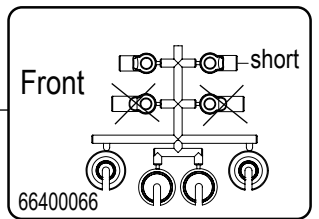
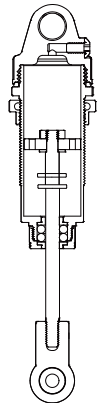

Part bags used.



Apply threadlocker (screw cement)



Do not over tighten.



Assemble in the specified order.

D1.2 Front & Rear Shock Assembly

BAG
D

Front Build x2
Rear Build x2

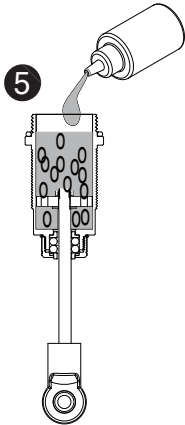

Initial Setting

Front shocks oil	Rear shocks oil
↑ 20° C 350Cst	↑ 20° C 350Cst
↓ 20° C 300Cst	↓ 20° C 300Cst

6

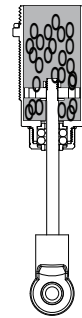

Slowly move up and down to remove air bubbles.

7

Do not over tighten

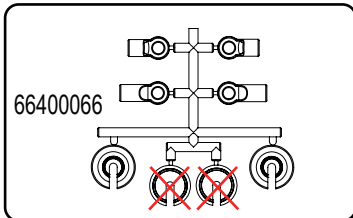
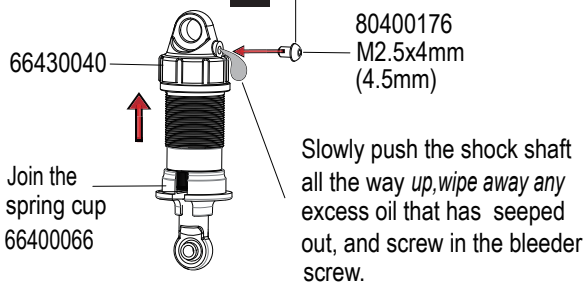

8

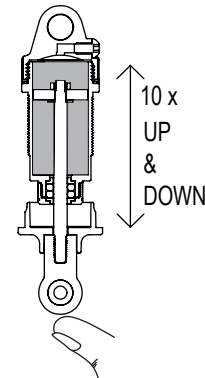

10 x push the shaft up and down.

9

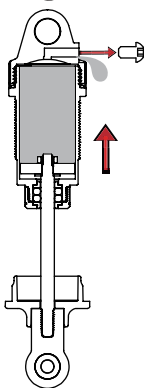

Untighten the screw.

10

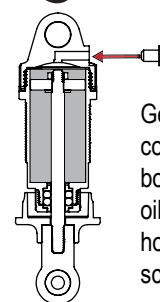

Gently push the shock shaft completely into the shock body. Wipe away any excess oil that flows through the hole in the shock cap and screw in the bleeder screw.



D1.3 Front & Rear Shock Assembly



Front Build x2 Initial setting

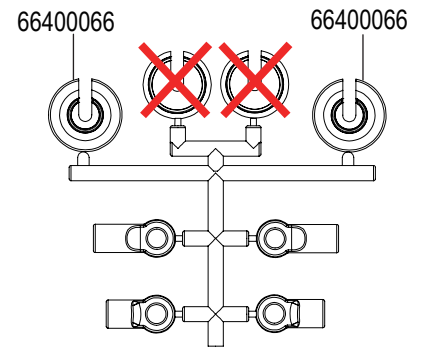
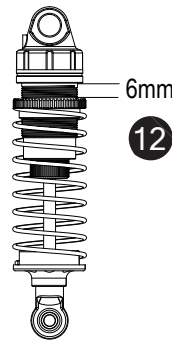
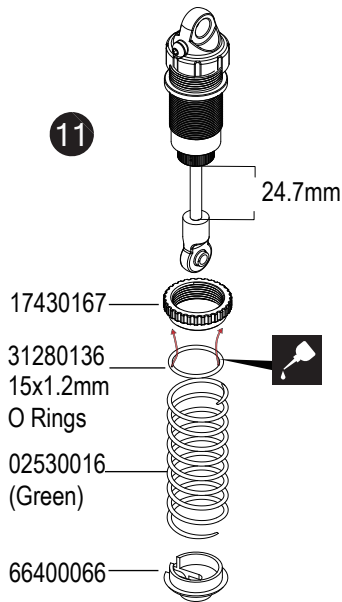

Rear Build x2 Initial setting

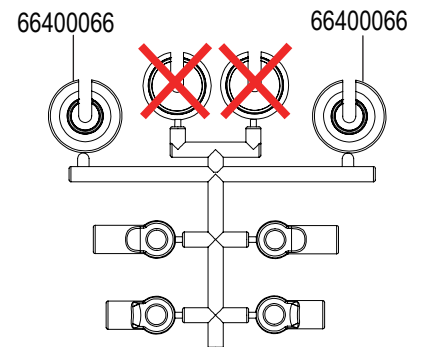
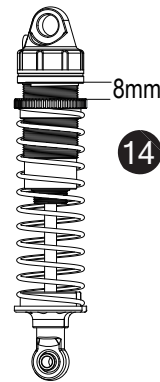
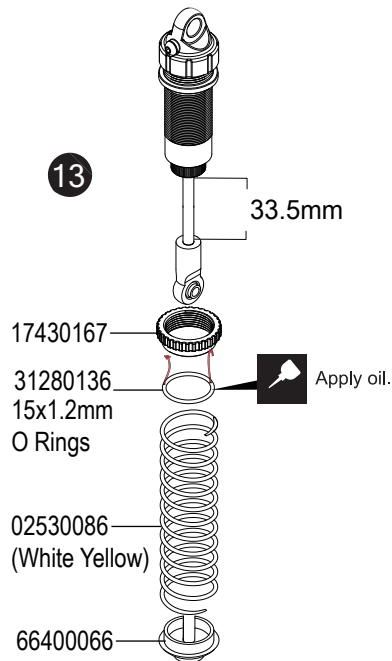

71530016-Type R Front Shock Spring Set

PART NO:	Color	kg mm	lbs/in
02500096	Transparent	0.053	2.97
02500106	Blue	0.058	3.25
02500146	White	0.061	3.42
02500116	Red	0.063	3.53
02500126	Yellow	0.068	3.81
02530016	Green	0.075	4.20
02530026	Black	0.080	4.48
02530036	Blue Red	0.085	4.76
02530046	White Yellow	0.090	5.04
02530116	Green Black	0.098-(RT)	5.88-(RT)

71530026-Type R Rear Shock Spring Set

PART NO:	Color	kg mm	lbs/in
02500056	Transparent	0.030	1.80
02500066	Blue	0.035	2.10
02500136	White	0.037	2.22
02500076	Red	0.040	2.40
02500086	Yellow	0.045	2.70
02530056	Green	0.050	3.00
02530066	Black	0.055	3.30
02530076	Blue Red	0.060	3.60
02530086	White Yellow	0.065	3.90
02530126	Green Black	0.073-(RT)	4.50-(RT)

Option



Part bags used.



Apply oil.







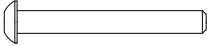

Assemble in the specified order.

PR S1 RM

BAG
D



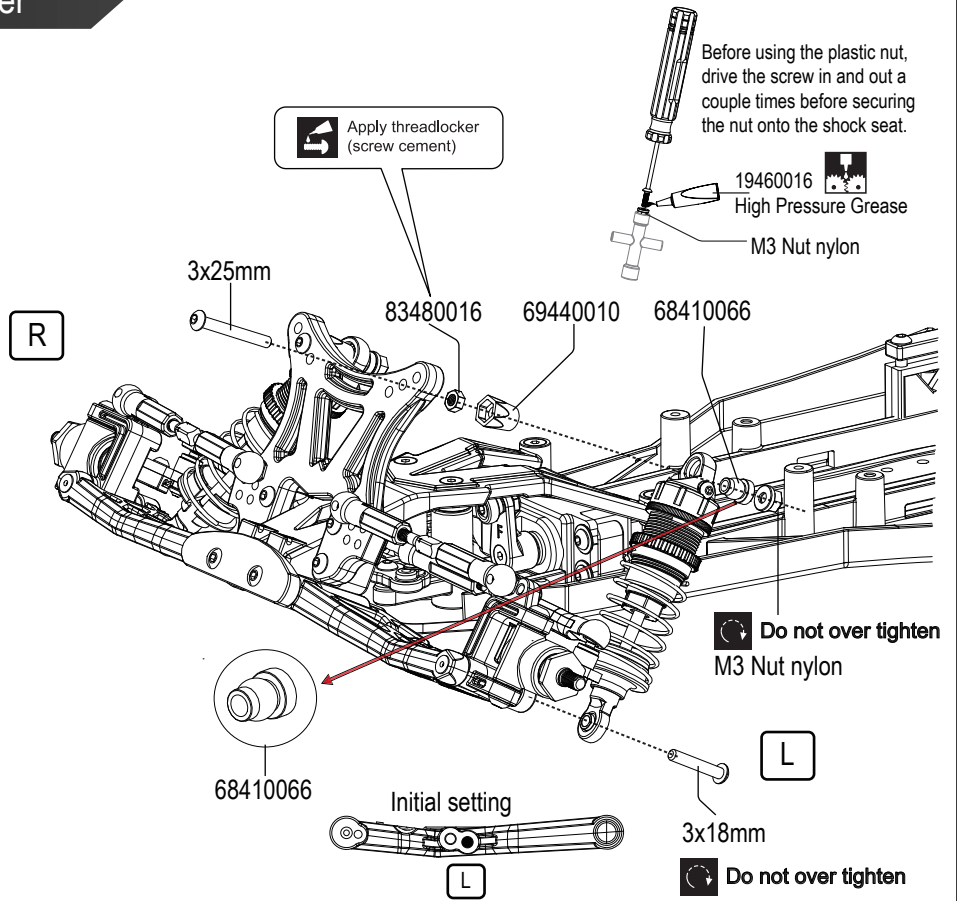

D2- Front Shock Tower

-  2
80400076 M3x25mm
-  2
80400196 M3 x18mm
-  2
68410066 M3 Nut nylon
-  2
68410066
-  2
69440010
-  2
83480016 M3 Nut

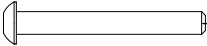
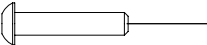

BAG
D

D3-Rear Shock Tower

-  2
80400076 M3x25mm
-  2
80400057 M3x15mm
-  2
68410066 M3 Nut nylon
-  2
68410066
-  2
69440010
-  2
83480016 M3 Nut

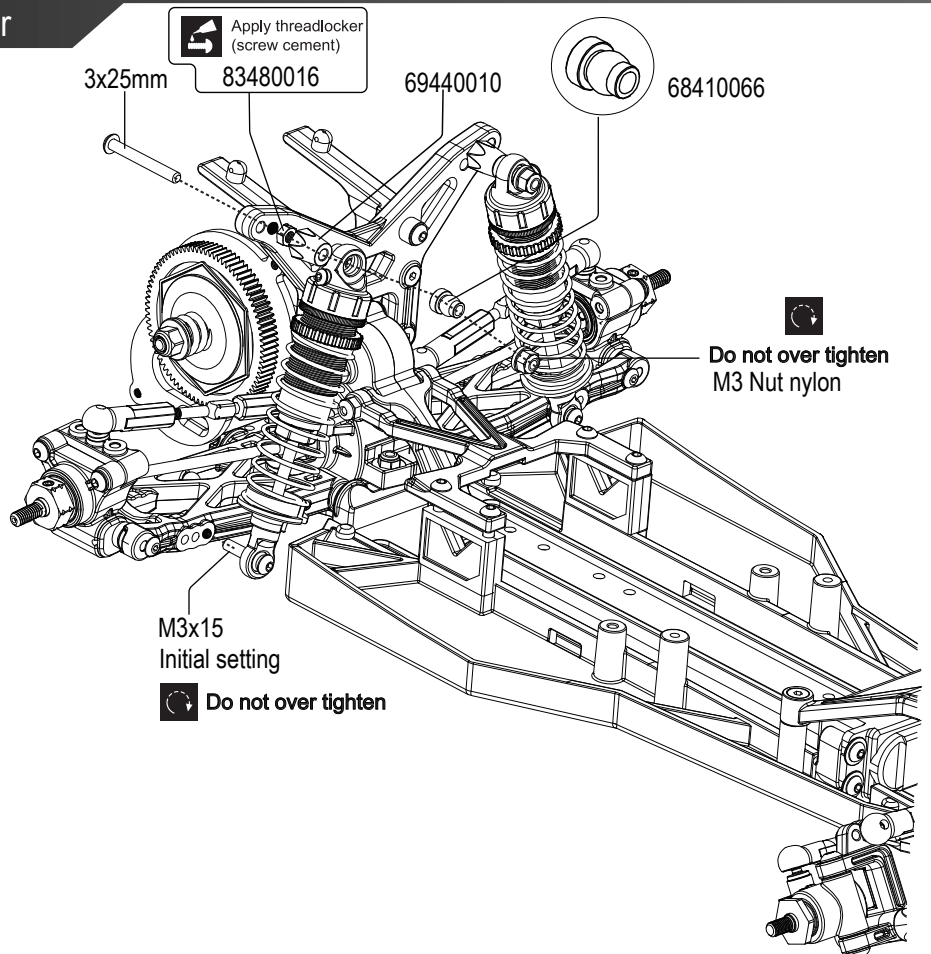



D4- Motor

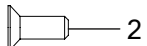

M3x8mm
82400026



X Must be purchased separately.

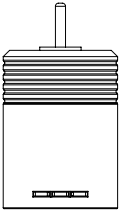

X Must be purchased separately.

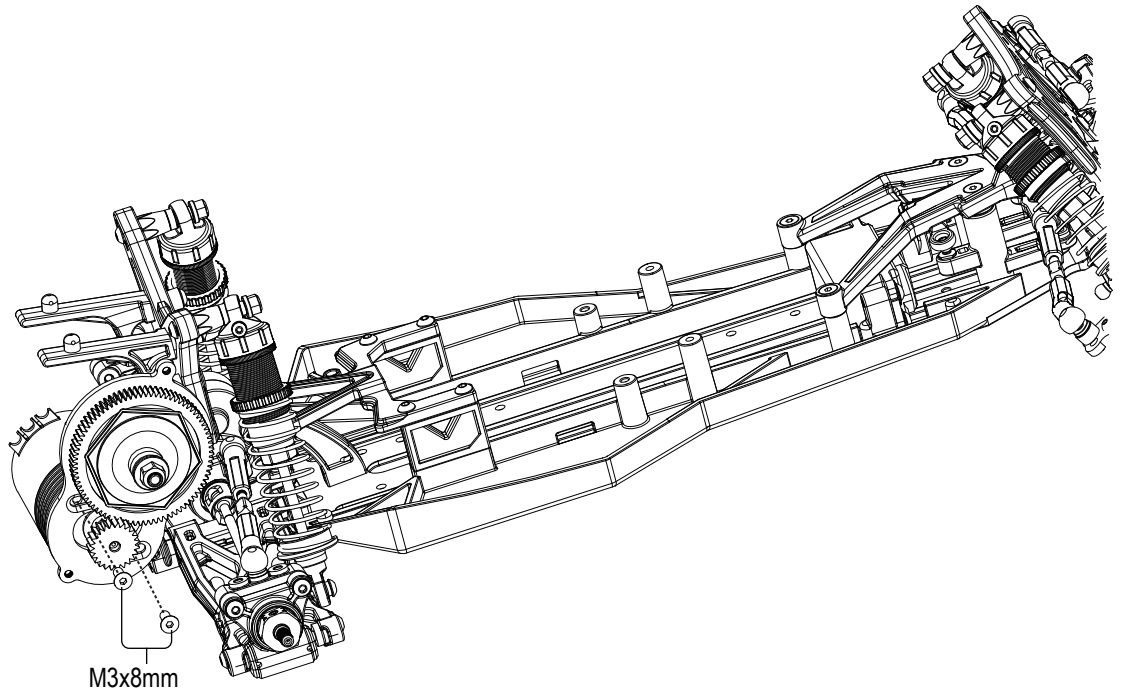

D5-Gear Cover Plug

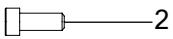

87400046
M2.6x6mm

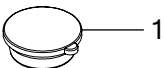

66400296

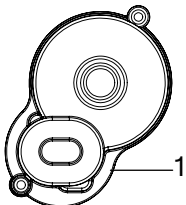

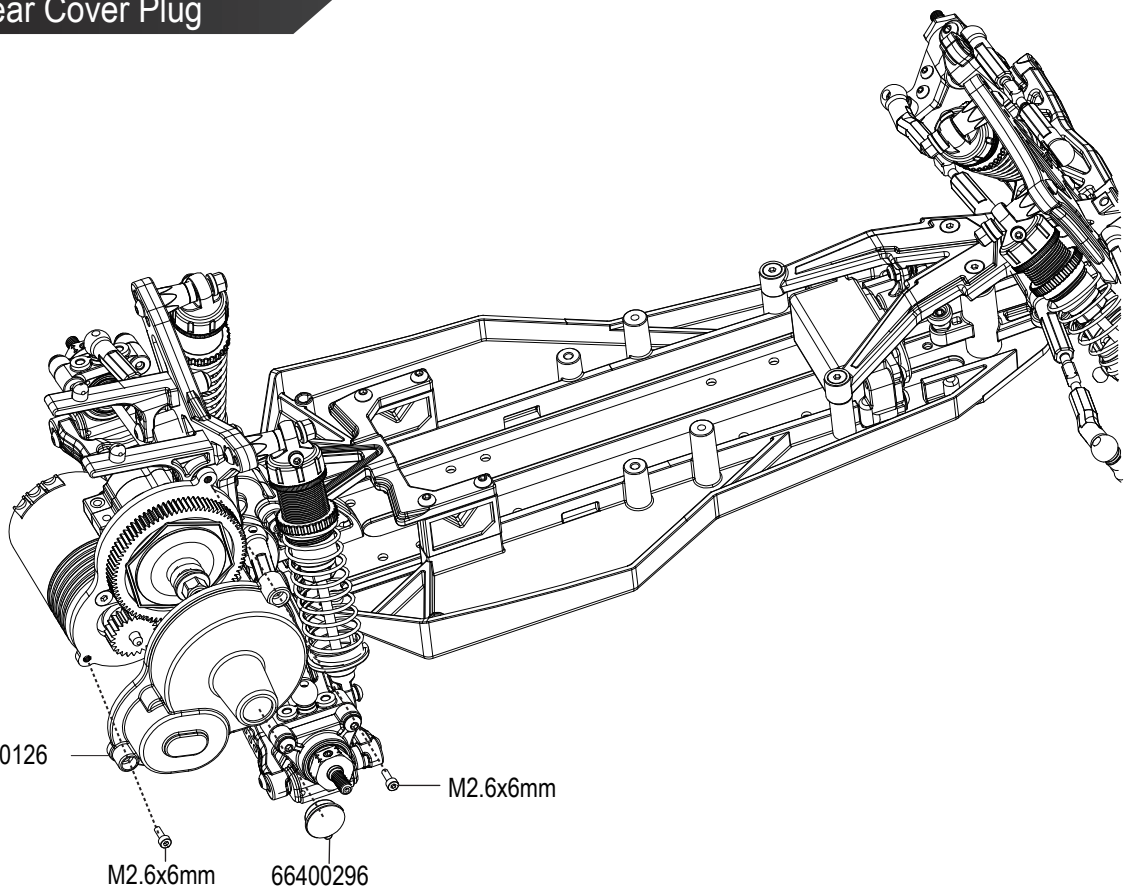

66400126



PR S1 RM





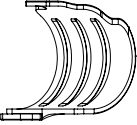

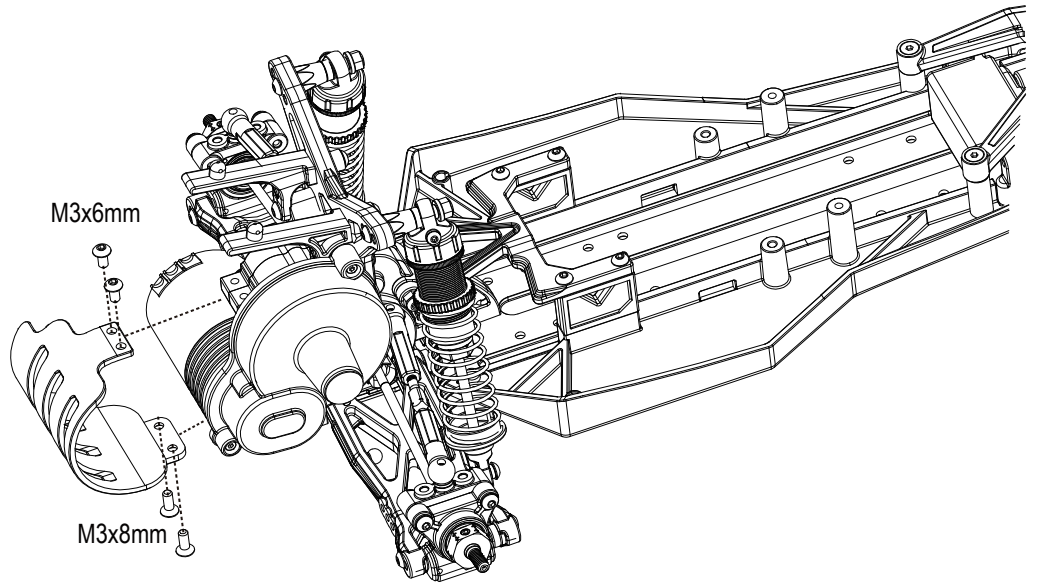
D6-Motor Cover

-  2
82400026 M3x8mm
-  2
80400026 M3x6mm
-  1
66400056

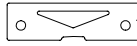

D7-Battery (Low Short)

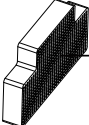
-  4
82400026 M3x8mm
-  2
87400036 Set Screw M3x16mm
-  2
66400126
-  2
66400036
-  1
66430020
-  1
77500276 Foam

Battery Selection

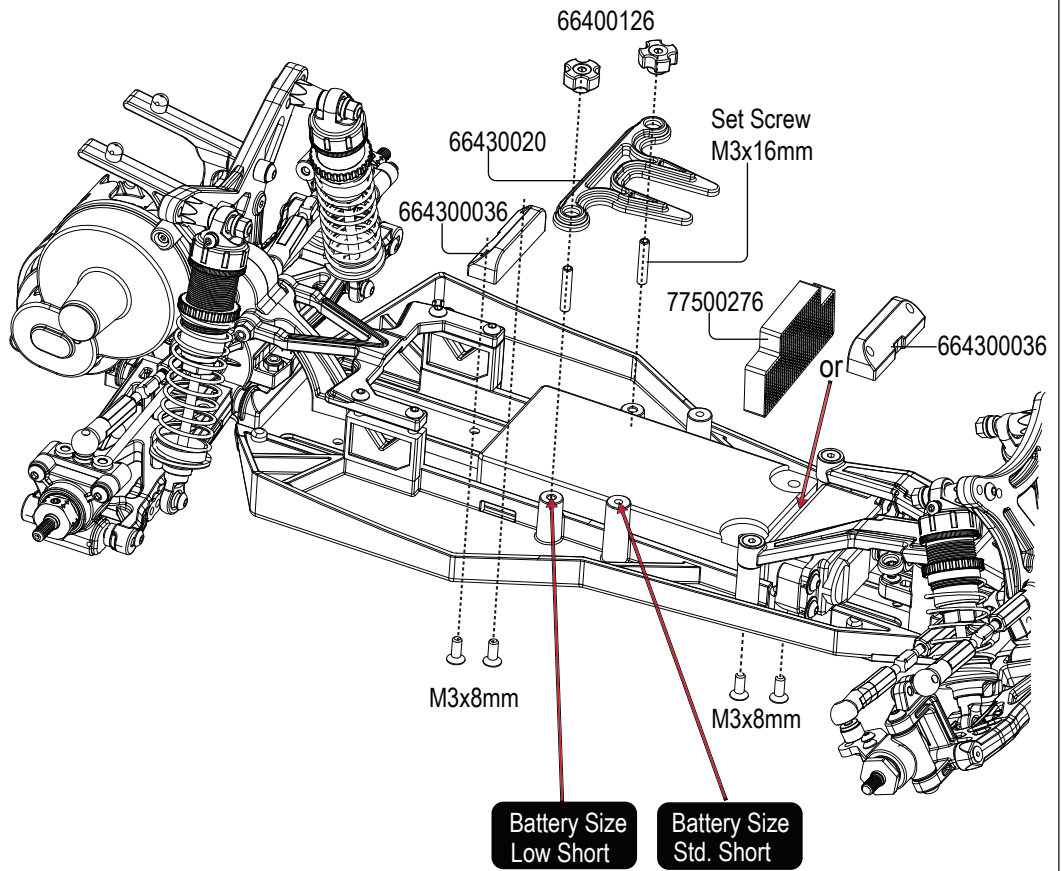



D8-Battery (Std. Short)

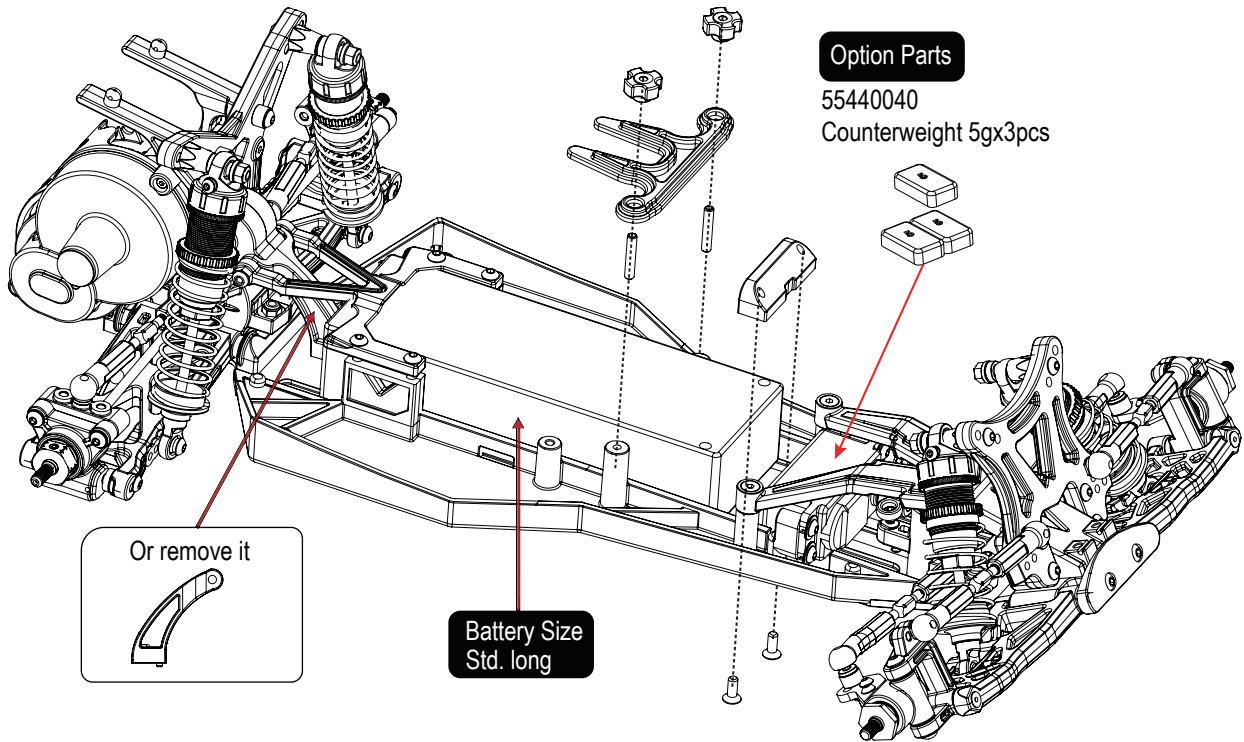

D9-Wing

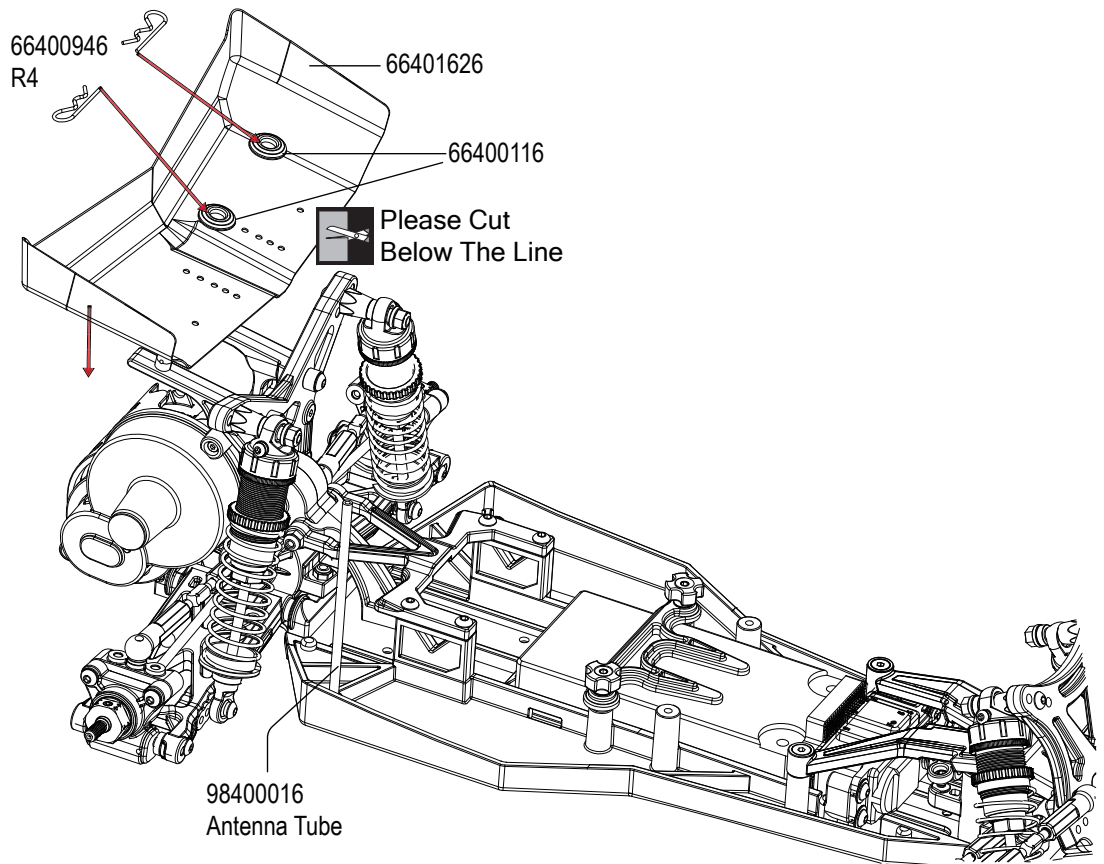
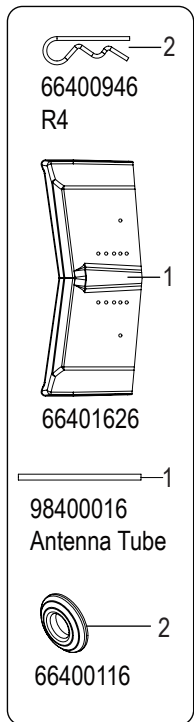

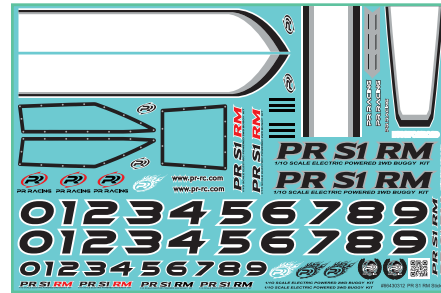
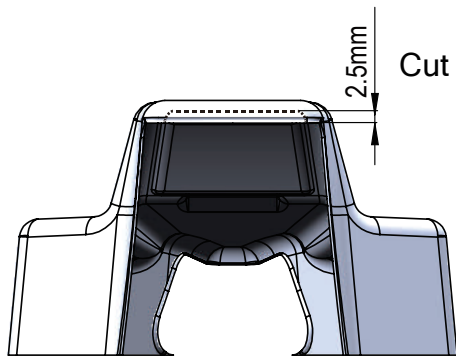

Body and Wing Cutting

Trimming on body and wing is required.
 For best paint results: -Scuff inside surfaces to be painted, be careful not to scuff windows.
 -Wash the inside of the body/wing with mild soap and warm water. -Dish washing liquid works great, be sure to rinse completely.
 -Wash hands before applying window masks and any graphic masking.

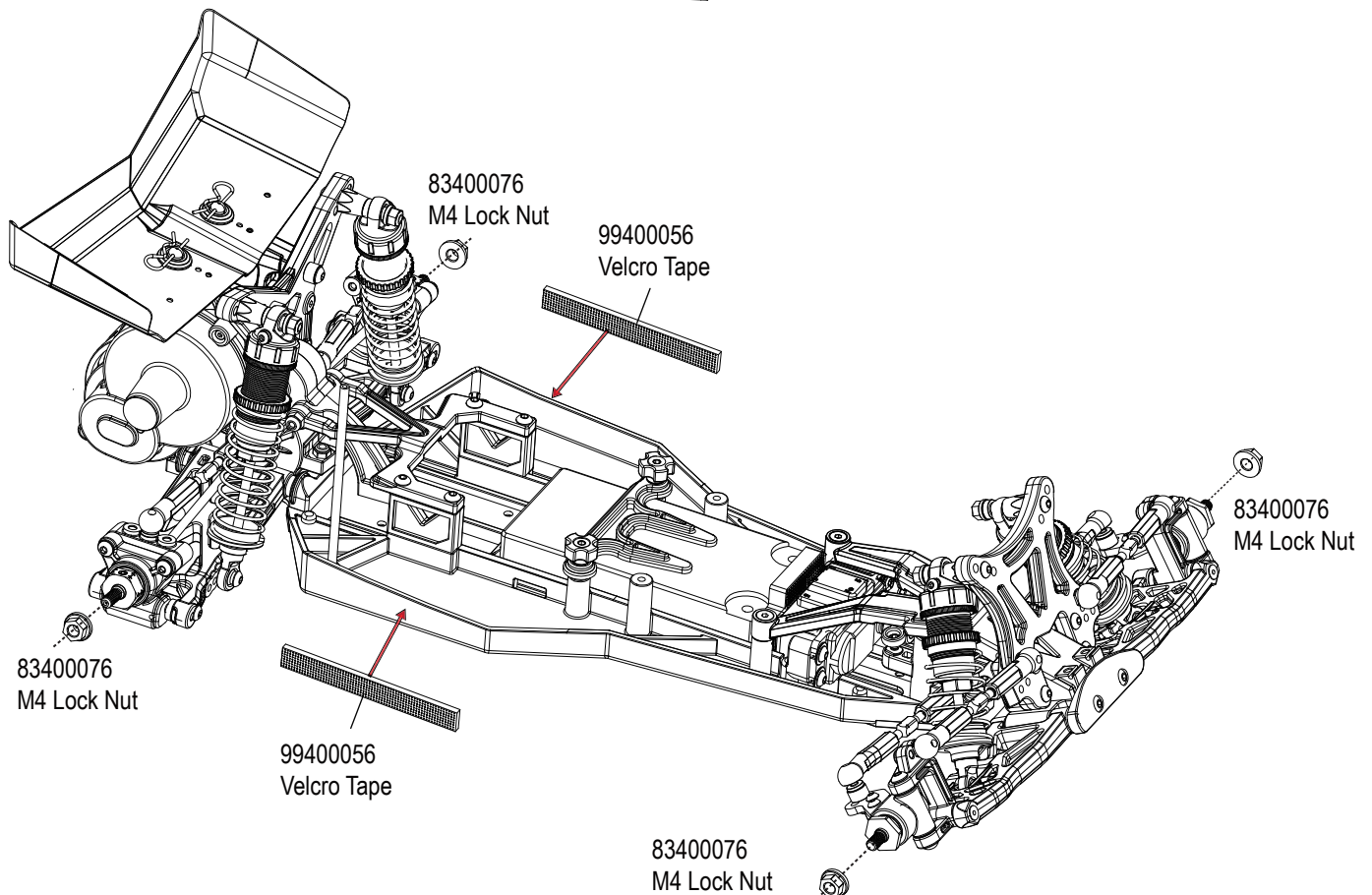
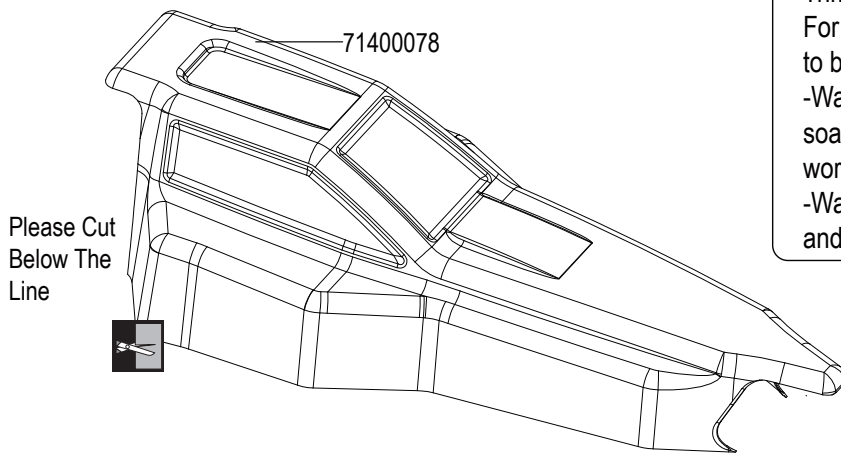

D11-ESC installation position

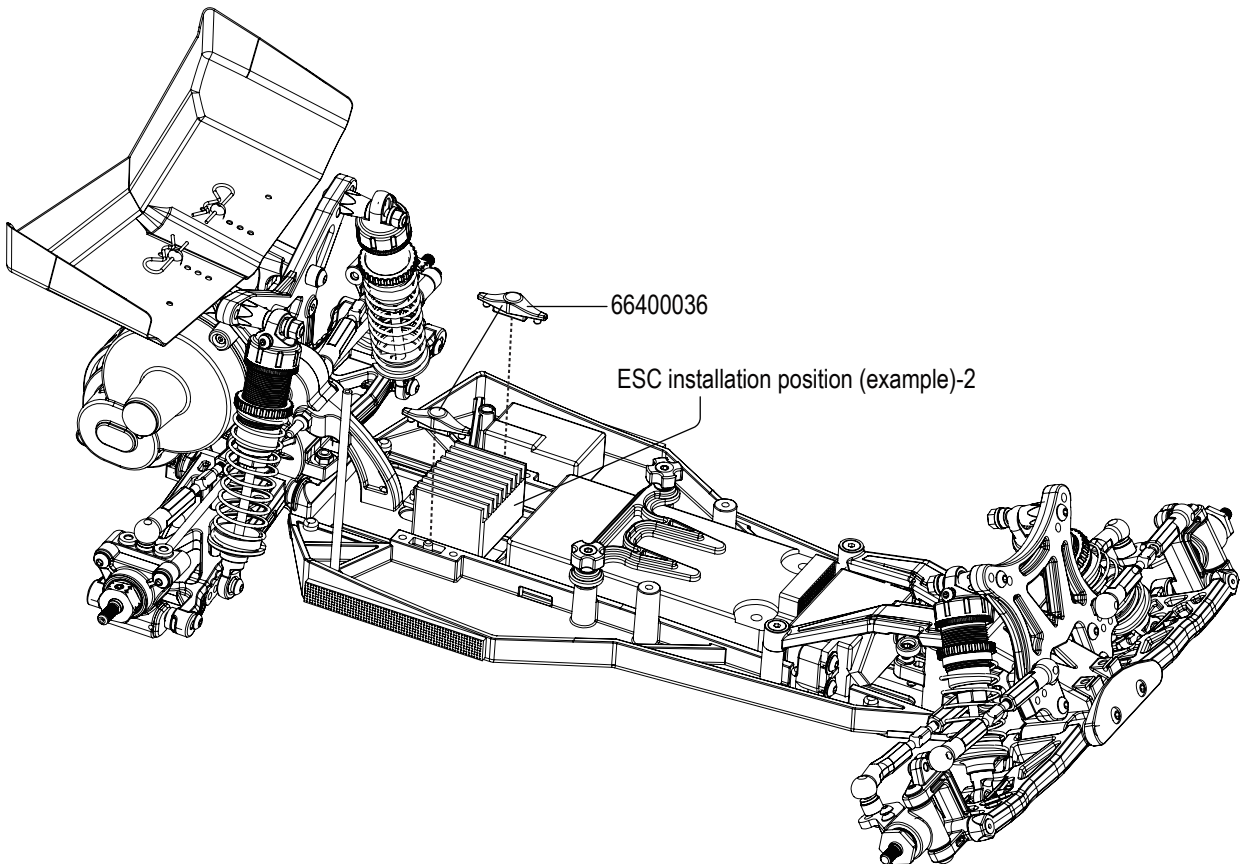
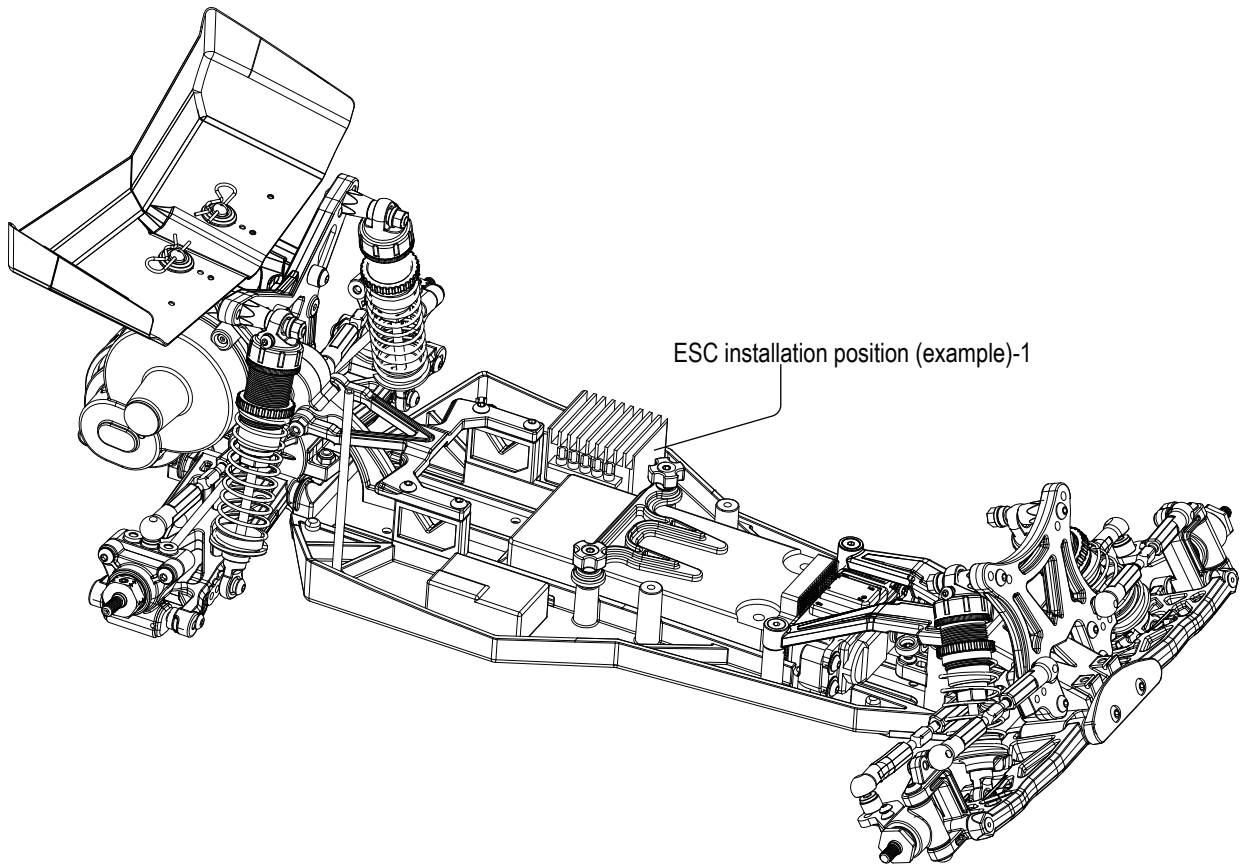





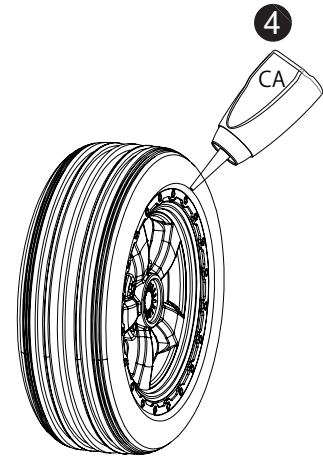
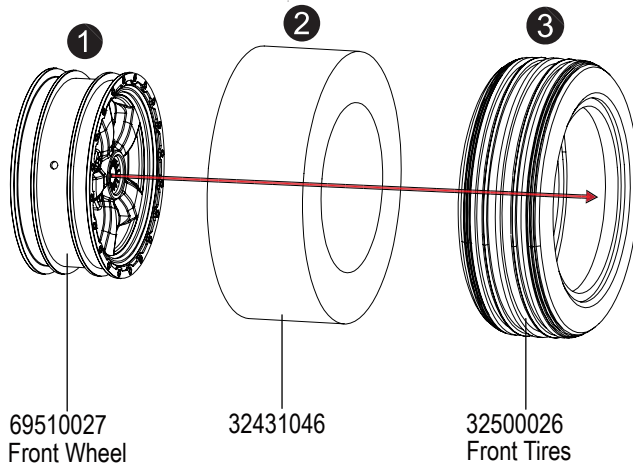



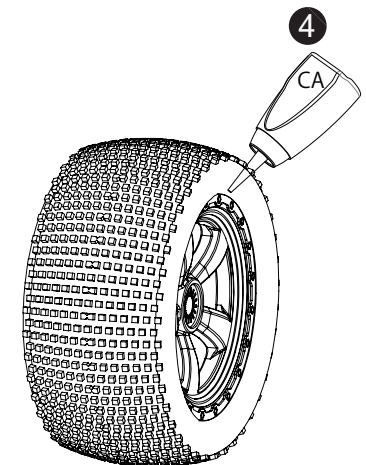
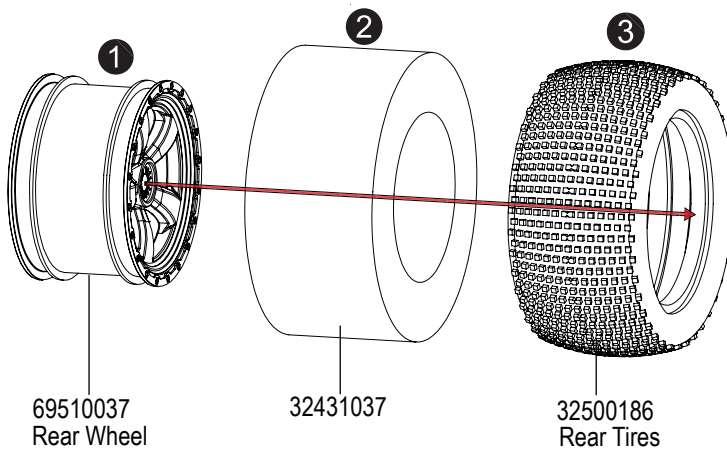





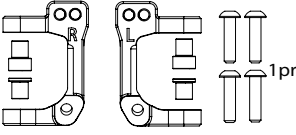

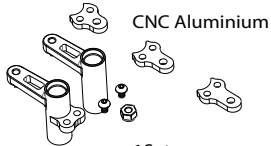
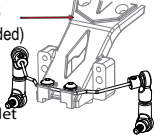
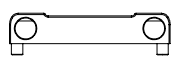
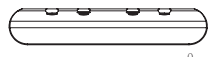

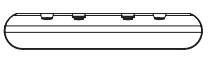
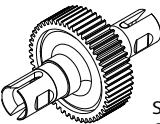
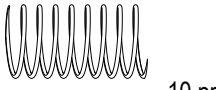
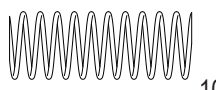
CA(Cyanoacrylate) glue sold separately.
Pull the sidewall of the tire slightly away
form the rim and apply CA(Cyanoacrylate)
glue in between the tire bead and rim

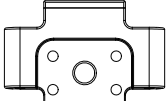
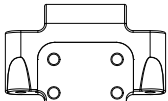
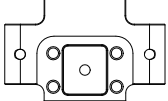
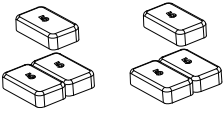
Place the tire insert into the tire and tire onto the wheel.

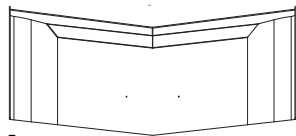
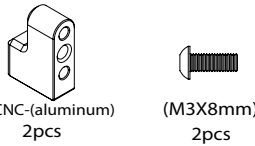

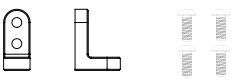
Place the tire insert into the tire and tire onto the wheel.

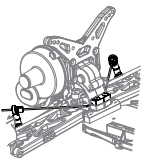

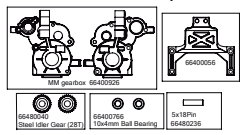
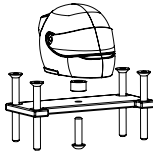
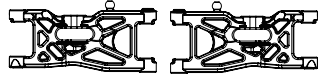
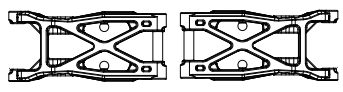
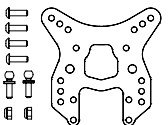
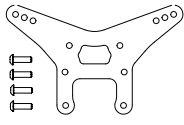
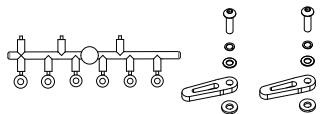
<p>66400376</p>  <p>1PCS (aluminum)</p>	<p>79400026</p> <p>Type-R</p>  <p>3x29.8mm 2PCS</p>	<p>79400036</p> <p>Type-R</p>  <p>3x36.8mm 4PCS</p>	<p>79400046</p> <p>Type-R</p>  <p>3x47.5mm 2PCS</p>
<p>91400039</p>  <p>CNC Aluminium</p>	<p>66430366</p> <p>Not included: 4.8mmx3mm Ball Studs</p>  <p>Type R Ackerman board CNC Aluminium-V3 (1)</p>	<p>66481256</p>  <p>CNC Aluminium</p> <p>1Set</p>	<p>66481556</p>  <p>75400036 (not included)</p> <p>(S1V3FM EVO) PR S1 V3 Front Anti-Roll Bar Drop Link & Collet 1.2mm.1.3mm1.4mm</p>
<p>71400236</p>  <p>1PCS (RF) CNC-(aluminum)</p>	<p>71400166</p>  <p>1PCS (RR-3.5) CNC-(aluminum)</p>	<p>71400096</p>  <p>1PCS (RR-3) CNC-(aluminum)</p>	<p>71400406</p>  <p>1PCS (RR-1.5) CNC-(aluminum)</p>
<p>66402687</p>  <p>S1 v4 Ball Diff Outdrive Set +1.3mm</p>	<p>71530016</p>  <p>10 pr Type R Front Shock Spring Set</p>	<p>71530026</p>  <p>10 pr Type R Front Shock Spring Set</p>	<p>55430086</p>  <p>25T CNC-(aluminum) 1PCS</p>
<p>66480456</p>  <p>(+3°)Caster lower swing arm mounts (aluminum)</p>	<p>66480536</p>  <p>(+7°)Caster lower swing arm mounts 66g (Brass)</p>	<p>66480476</p>  <p>(+0°)Caster lower swing arm mounts (aluminum)</p>	<p>55440040</p>  <p>6pcs Counterweight 5g</p>
<p>81430106</p>  <p>4PCS front Rear Steel Shock Stand off Set</p>	<p>66402697</p>  <p>1.5 mm 1PCS</p>	<p>66480936</p>  <p>CNC-(aluminum) 2pcs (M3X8mm) 2pcs</p>	<p>66400696</p>  <p>4PCS Aluminium Shock Stand off Set - Black</p>
<p>66481176</p>  <p>2PCS PR S1 Front Shock Tower Camber Plate</p>	<p>23440360</p>  <p>(aluminum) 1PCS M5.5mm</p>	<p>66481446</p>  <p>2pcs Battery retaining nut +oring(Black)</p>	<p>66480736</p>  <p>1set</p>
<p>68440096</p>  <p>S1V4/RM Rear +1mm 2pcs</p>	<p>67000020</p> <p>PR S1 V1 MM-Kitpack</p>  <p>MM gearbox 66400025 66480249 Steel Idler Gear (25T) 66400296 1204mm Ball Bearing 5x18Pin 66480236</p>	<p>71400079</p>  <p>PR SC/RM Rear Carbon Fiber Shock Tower 4mm (1)</p>	<p>69400157</p>  <p>PR S1 V4 Front Lower gull Wishbone Graphite (Hard) (1pr)</p>
<p>69400186</p>  <p>PR S1 V4 Rear Lower gull Wishbone Graphite (Hard) (1pr)</p>	<p>67480017</p>  <p>PR SC/RM Front Carbon Fiber Shock Tower 4mm (1)</p>	<p>66480256</p>  <p>PR SC/RM Rear Carbon Fiber Shock Tower 4mm (1)</p>	<p>91400037</p>  <p>Carbon Fiber Battery Hold Down</p>

Name _____

Date _____

Track/City _____

Event _____

Front Suspension

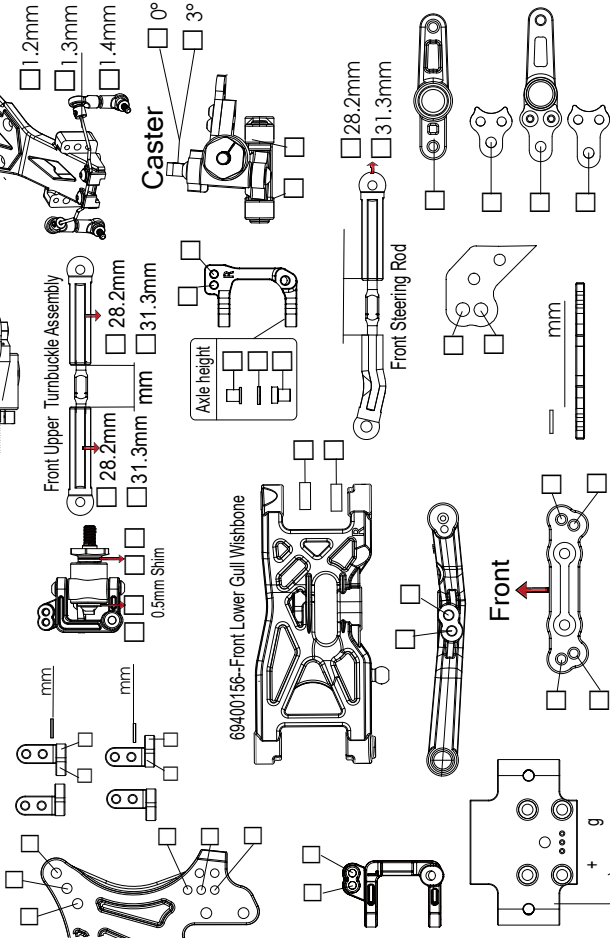

Camber		mm
Ride Height		mm
TOE In Out		mm
Type R		mm
Shock Spring		mm
Oil		transparent
Pistons		Red

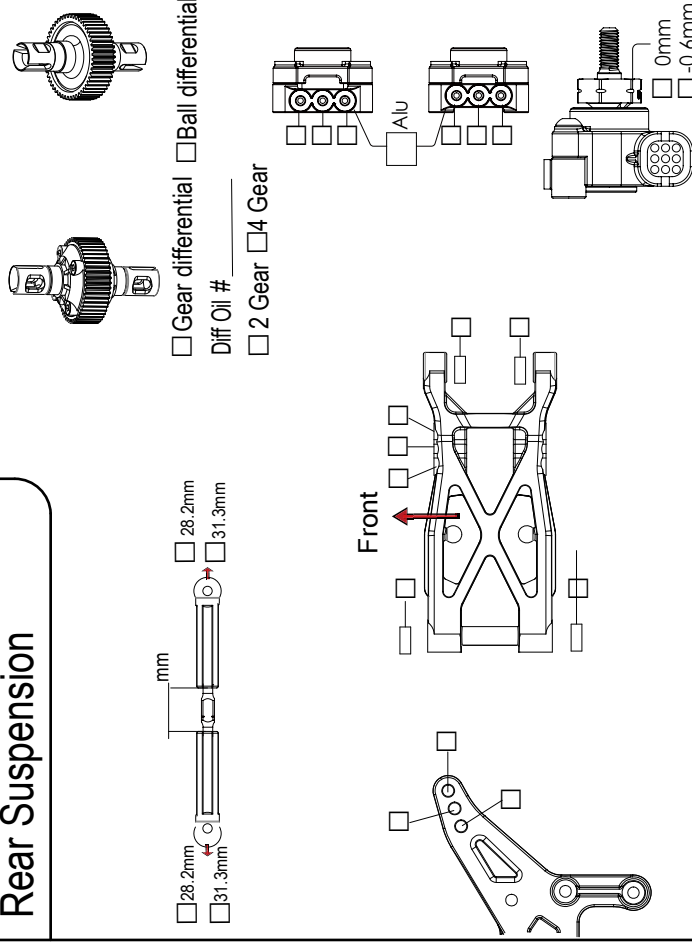

Holes		mm
Shim		mm
Up stop		mm
Length		mm
O Rings		transparent
Red		

Rear Suspension



0mm	
-0.6mm	
-1.2mm	

Front	Motor	T	Spur Gear	T	Size	<input type="checkbox"/> Open <input type="checkbox"/> Medium <input type="checkbox"/> Tight	Body	<input type="checkbox"/> Standard <input type="checkbox"/> Light
Tire	Pinion	T			Traction	<input type="checkbox"/> Very-Low <input type="checkbox"/> Medium <input type="checkbox"/> Very-High	Wishbone	<input type="checkbox"/> High Hardness <input type="checkbox"/> Medium Hardness
Inserts	Esc				Surface	<input type="checkbox"/> Smooth <input type="checkbox"/> Medium <input type="checkbox"/> Bumpy	Rear	<input type="checkbox"/> High Hardness <input type="checkbox"/> Medium Hardness
Wheels	Servo	<input type="checkbox"/> Std. Profile Servo <input type="checkbox"/> Low Profile Servo			Type	<input type="checkbox"/> Clay <input type="checkbox"/> Carpet <input type="checkbox"/> Astro	Ride Height	F R
Tire	Battery Size	<input type="checkbox"/> Std. Short <input type="checkbox"/> Std. Long			Condition	<input type="checkbox"/> Blue Groove <input type="checkbox"/> Hard Packed <input type="checkbox"/> Dry <input type="checkbox"/> Wet		
Inserts					Apply CA Glue if needed			
Wheels								Others

 PR S1 RM (Gear Diff) Gear Ratio Chart-Internal Gear Ratio 2.75:1									
(Gear Diff) Final Drive Ratio		 Spur							
									Option Parts
					73	75	77	81	83
Pinion	18								
	19								12.01
	20								11.41
	21							10.61	10.87
	22							10.13	10.38
	23							9.68	9.92
	24						8.82	9.28	9.51
	25						8.47	8.91	9.13
	26						8.14	8.57	
	27					7.64	7.84		
	28					7.37	7.56		
	29				6.92	7.11	7.30		
	30				6.69	6.88	7.06		
	31				6.48	6.65	6.83		
32				6.27	6.45				
33				6.08					

Option Parts		Pinion 	
66480986	PR Racing 48P Pinion (3.17mm ID) (18T)*1pcs	66481576	PR Racing 48P Pinion (3.17mm ID) (26T)*1pcs
66480996	PR Racing 48P Pinion (3.17mm ID) (19T)*1pcs	66481586	PR Racing 48P Pinion (3.17mm ID) (27T)*1pcs
66481006	PR Racing 48P Pinion (3.17mm ID) (20T)*1pcs	66481596	PR Racing 48P Pinion (3.17mm ID) (28T)*1pcs
66400556	PR Racing 48P Pinion (3.17mm ID) (21T)*1pcs	66481606	PR Racing 48P Pinion (3.17mm ID) (29T)*1pcs
66480096	PR Racing 48P Pinion (3.17mm ID) (22T)*1pcs	66481616	PR Racing 48P Pinion (3.17mm ID) (30T)*1pcs
66480106	PR Racing 48P Pinion (3.17mm ID) (23T)*1pcs		
66480116	PR Racing 48P Pinion (3.17mm ID) (24T)*1pcs		
66481566	PR Racing 48P Pinion (3.17mm ID) (25T)*1pcs		

PR S1 RM

1/10 SCALE ELECTRIC POWERED 2WD BUGGY KIT



EMAIL / infopracing@gmail.com.tw

1.2 Version