

PRS1 (FM)

V4R

1:10 Scale 2WD Off Road Electric Competition Buggy Kit

ITEM NO:75400056

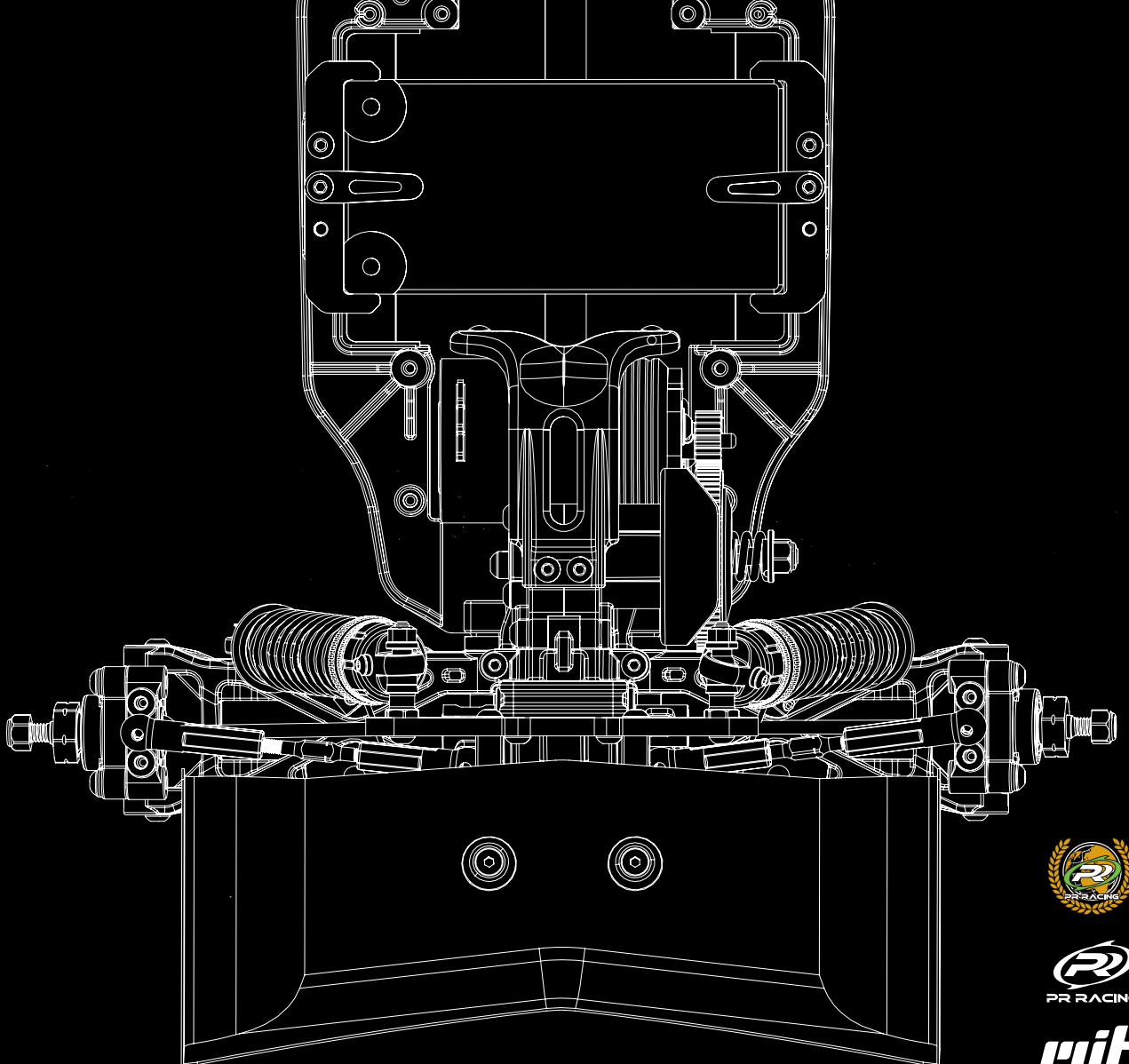

Specifications

- Length: 411mm
- Width: 248mm
- Height: 145mm
- Wheelbase: 280mm
- Front track: 248mm
- Rear track: 248mm
- Weight: 1420-1510g
- 12.8mm big-bore oil-filled shocks
- 3 Gear box with 3-gear transmission
- Metal gear differential
- Dual pad slipper clutch
- Complete sealed ball bearing set
- 12mm hex fit wheels
- Metric socket screw (Hex Screws)

Items Required To Complete

- Metric 1.5mm, 2.0mm hex tools
- Metric 5.5mm, 7.0mm nut driver
- 2 Channel surface radio system (Minimum)
- 1/10 ESC, motor & pinion gear
- High Speed Servo
- 2S LiPo shorty battery & compatible Lipo charger
- Polycarbonate paint for bodies
- 1/10 Buggy tires, inserts and CA glue



Manual connection

#75400056

PR S1 V4 R (FM) 1/10 Electric 2WD Off Road Buggy PRO Kit (Gear Diff Version)

PR V4R FM retains the main elements of the V3R. With the V4R, we have added more chassis flex options and quick adjustment design concepts.

Battery Mounting: A change was made to the mounting arm system, which increase chassis flex and also keeps the battery retainment method of the V3R. So using the V3R battery retainer plates, chassis flex can be decreased if needed.

Battery Placement: The front to rear weight can be quickly changed by moving the battery pack forward or back with ease.

Quick adjustments: The new quick access gearbox allows for faster adjustments of gear diff and easy maintenance of ball diffs.

Chassis Design: The 3mm thick chassis has more CNC machining done to create a lighter part along with moving the the car's center of gravity to a more optimized position.

The PR V4R FM inherits the stability of the previous generation and builds on it. For those with a spare parts bank already, you will be happy to know that instead of a completely new model, we have only redesigned the parts that needed to be. This makes it very easy to upgrade your previous model with the latest parts.

PR V4R FM保留了V3R的穩定元素，在V4R這版本中我們加入了更多扭動/重心轉移及快速調整的設計理念。

首先，電池的固定改為側向，完整釋放更多的扭動效應，但也保留了V3R的電池固定方式，有二種方式可供選擇。

再來藉由可調電池前後位置，讓車體重心的調整更加多元，快速改變前後重量比。

至於快速調整的部份，則是把重點放在後齒輪箱，以往更換差速器需要拆除許多的螺絲，V4R則改為快拆式設計，針對不同場地快速更換差速器。底盤選用3mm厚度，並搭配更多的鏤空加工，不僅減少了重量更讓後齒輪箱及馬達重心再次下降。

透過更精確的計算，大幅度的降低了整體的重心並更加前移。

PR V4R FM承襲了前一代的穩定性並加以優化。為了讓一直以來的支持者能沿續更多的零件。

而不是一年就必須更換一個新的車種，又要能找出更好的設計方向。雖然花了許多時間，但我們實現了～

● BEFORE INSTALLATION	01
● BAG A	03-06
Chassis Guard Installation	
Steering Bellcranks	
Steering Servo	
● BAG B	06-11
Front Suspension	
Front Spindle (L&R) Side	
Front Suspension (L&R)	
Front Upper Turnbuckle Assembly	Rear Hud & CVA
Turnbuckle Assembly-Steering Rod	Rear Hud (L&R)
	Rear Suspension
● BAG C	12-18
Gear Differential	
Transmission Assembly	
Rear Shock Stay	Rear Shock Stay
Rear Gear Box	Rear Suspension
	Rear Upper Rod Turnbuckle Assembly
● BAG D	19-25
Front & Rear Shock Assembly	
Front Suspension	
Rear Suspension	
Motor	
Battery Plate	
Body & Wheels	
Tires	
● SETUP SHEET	26
● SPARE PARTS & OPTIONAL PRTS	27

BEFORE INSTALLATION

- 1 Read through the instruction manual before installation in order to have an overview of what to do.
- 2 Check if there is any missing bags or defective parts, if there is, please contact our local dealer or our PR Distributor.
- 3 Symbols used throughout the instruction manual, comprises of:



Part bags used.



Assemble as many times as specified (here: twice).



Tighten securely.



Note the direction.



True-to-scale diagram.



Do not over tighten.



Must be purchased separately.



Apply threadlocker (screw cement)



Ensure smooth non-binding movement while assembling.



Assemble in the specified order.



Apply grease.



Cut off shaded portion.



Assemble left and right sides the same way.



Apply oil.

- 4 This kit contains screws and hardware in different metric sizes and shapes. Before using them, check the screws on the true-to-scale diagrams on the left side in each assembly step. Some screw are extras.

TOOLS REQUIRED

CAUTION: Handle tools carefully!

- Needle Nose Pliers

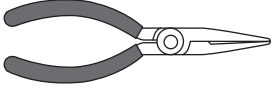

- Sharp Hobby Knife

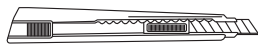

- Grease



- Round Cutter & Sander

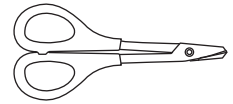

- Hex Wrench

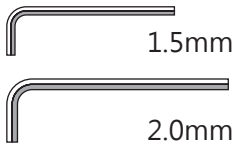

- Ball Differential Grease



- Screw Cement

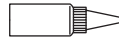

- Wire Cutters



- SP Knife Edge Reamer

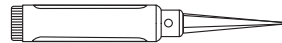

- Silicon Diff Oil

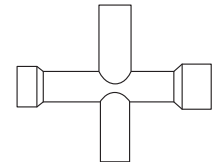

Cross Wrench

- 5.0mm-5.5mm
- 7.0mm

HEALTH WARNING

This model is a high performance radio controlled racing product that is designed for use on R/C car race tracks. If it is misused it could cause injury to the operator or others. Many of the items in this kit are small enough to be accidentally swallowed; therefore, it is not suitable for young children. All items, inclusive of liquids, contained in this kit are not intended for human consumption. Rotating parts of the car may cause injury if not handled with care.

RADIO PREPARATION

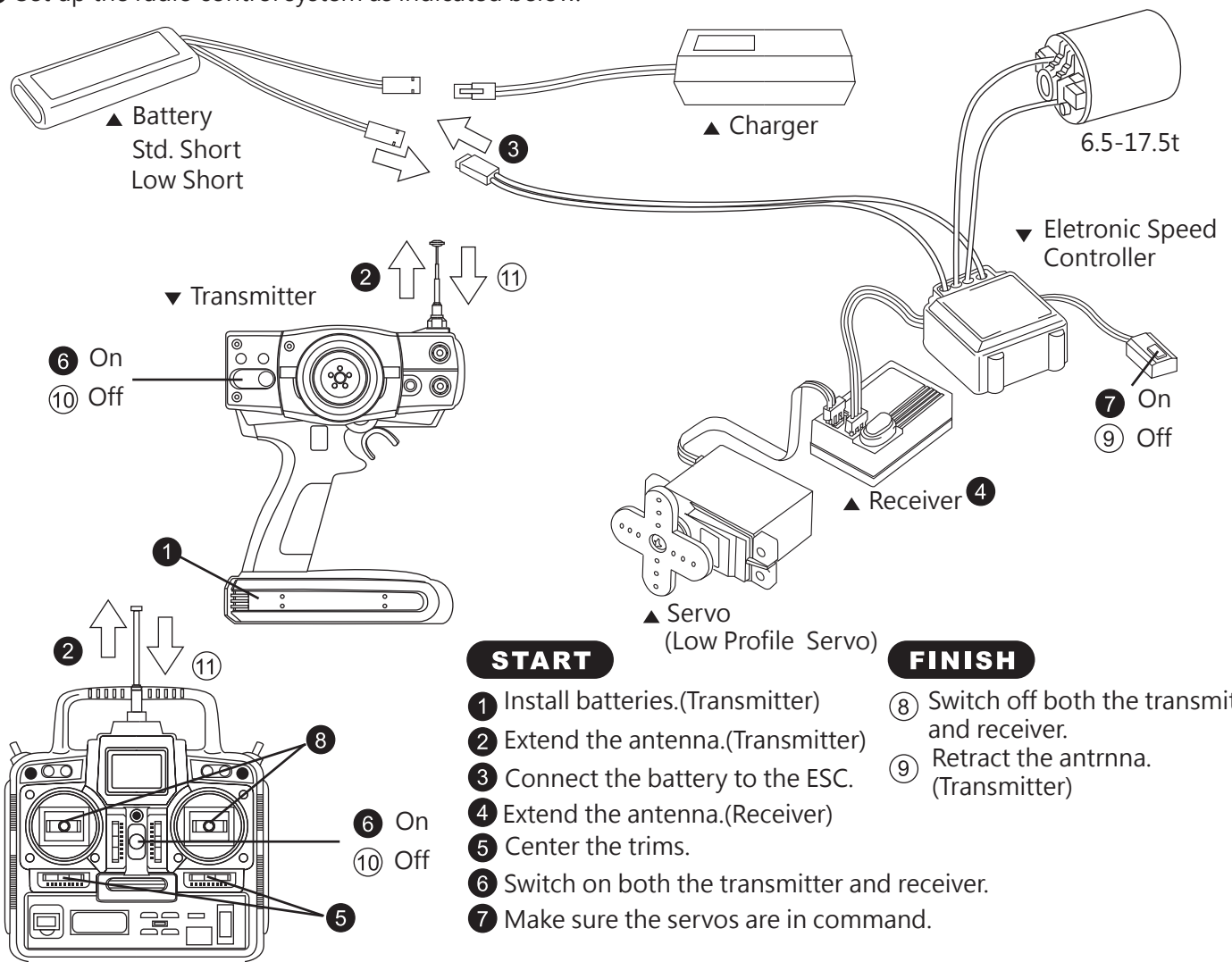

- A new battery must be charged before it is used. Refer to the charger instruction manual for charging.
- Set up the radio control system as indicated below.





BAG
A

A1 Chassis Guard Installation

-  10
82400016
M3x6mm
-  6
82400026
M3x8mm

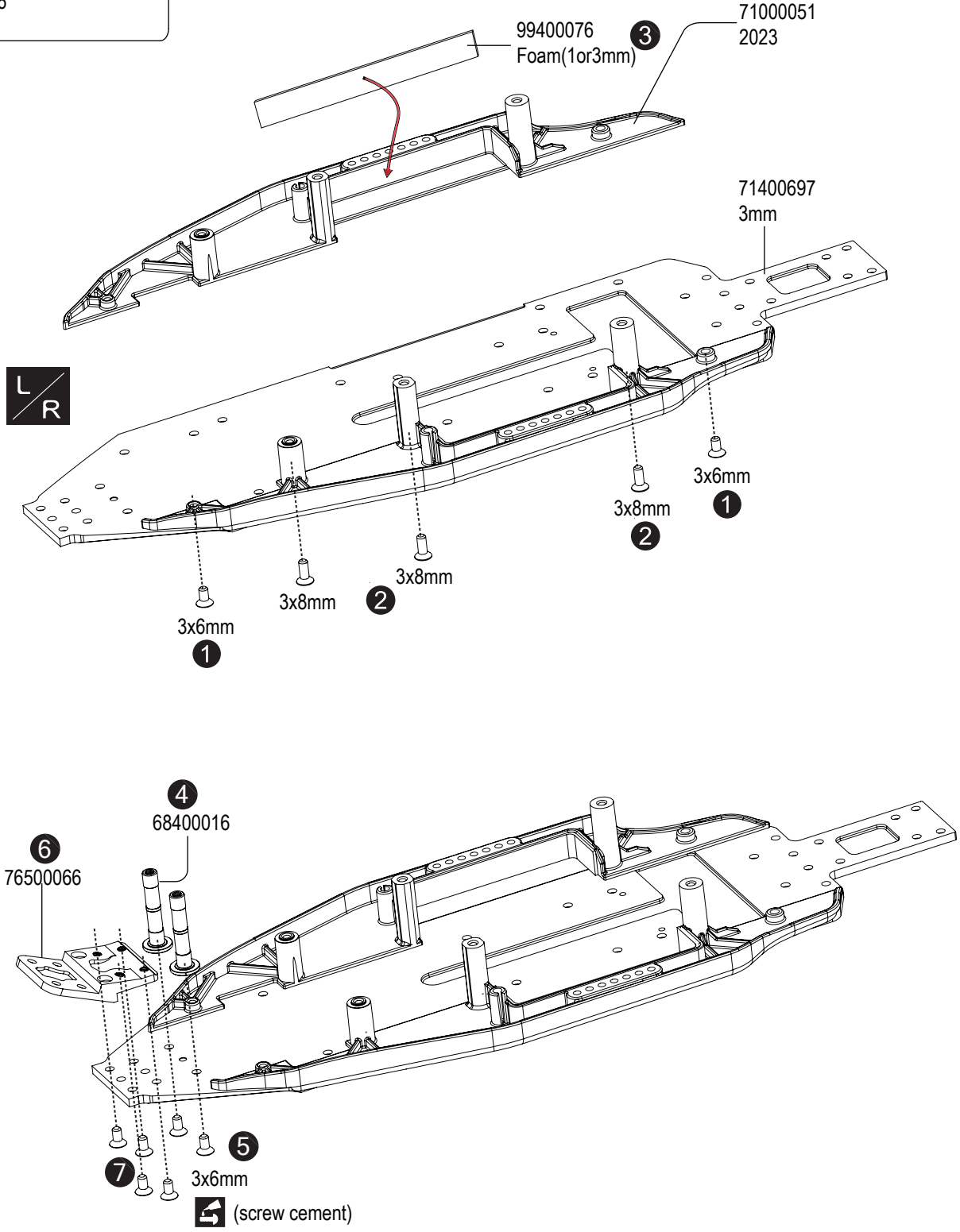

Part Bags used.



Assemble left and right sides the same way.



Apply threadlocker (screw cement)



Assemble in the specified order



BAG
A

A2 Steering Bellcranks

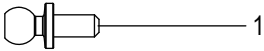

1
68430036 M4.8x6mm

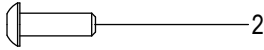

2
80400046 3x10mm



2
85430026 Shim 3x10x0.8mm



2
00430025
Steering Knuckle Bushing 3x6mm

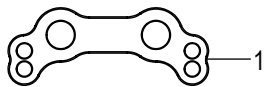

1
66430366
Ackerman Aluminium

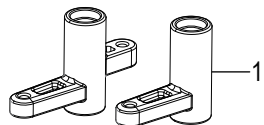

1
68480036
Steering Linkage

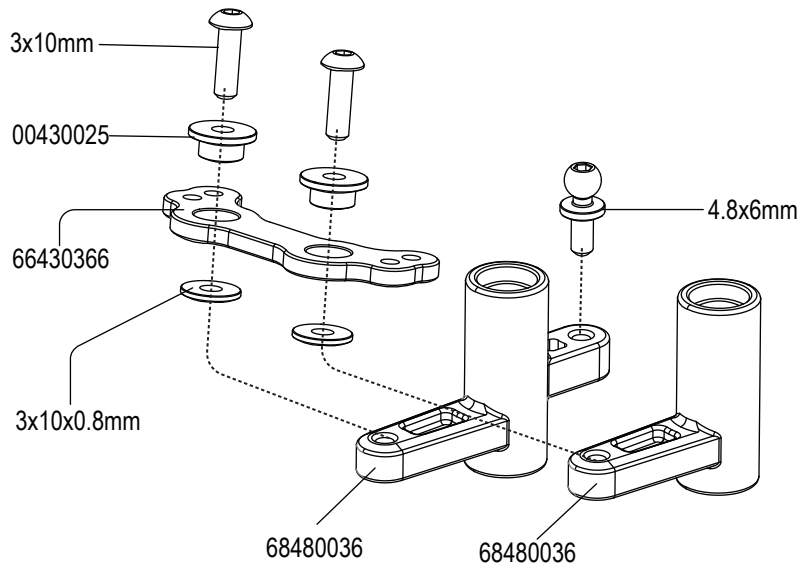

BAG
A

A3 Steering Bellcranks

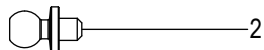

2
68430026
M4.8x3mm

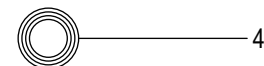

4
66400756
5x8x2.5mm Ball Bearing

Responsive

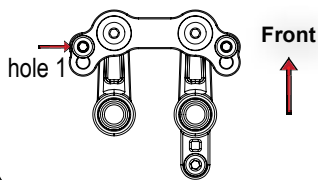

Stable

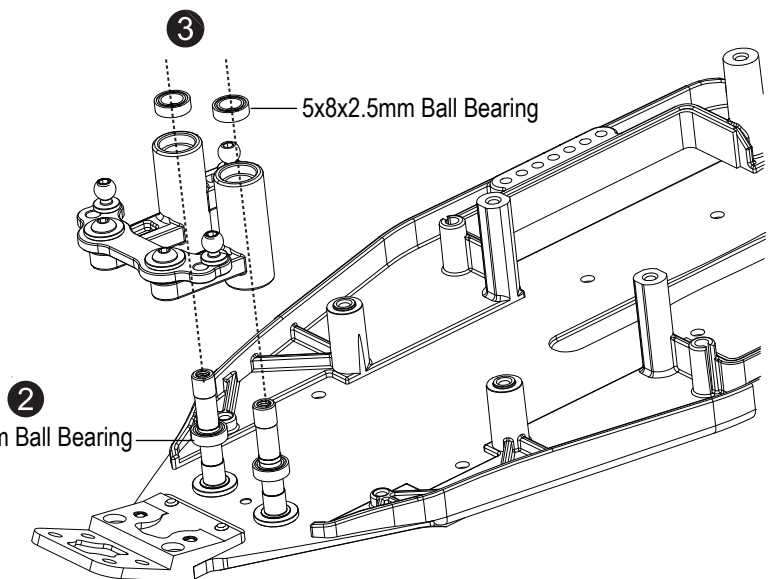
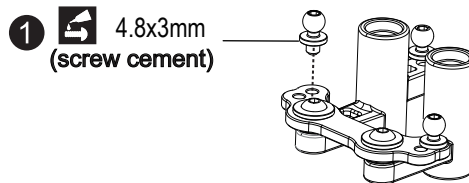
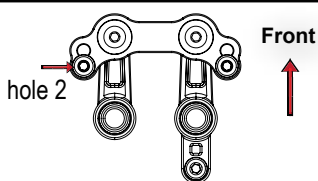



BAG
A

A4 Steering Servo

1
87400096
M3x8mm Set Screw

1
68430086
M4.8mmx6mm Ball Studs

1
82400106 M3x10mm

1
83400106 M3 Nut

1
66400036
Servo horns

2
66400066
Rod End

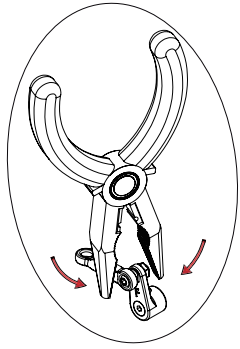
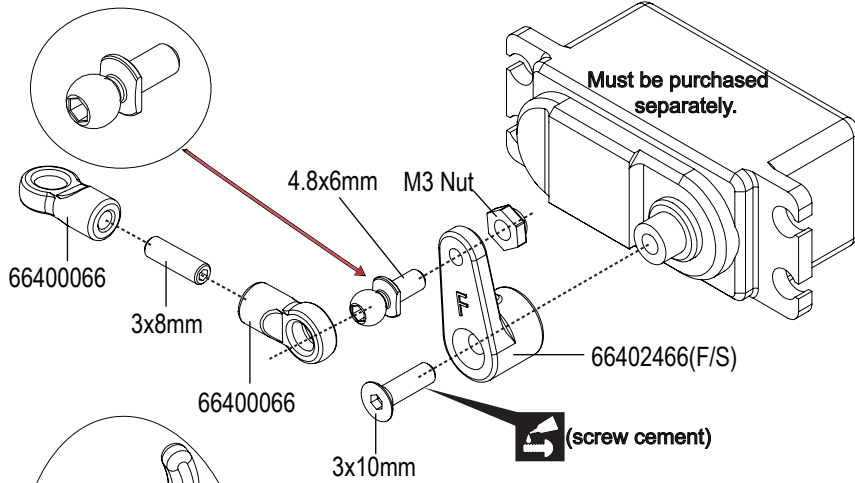

Modify

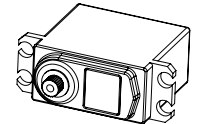

Std. Profile Servo

Stock

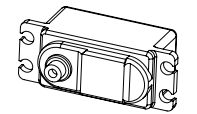

Low Profile Servo

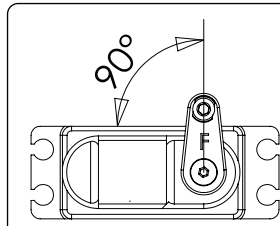
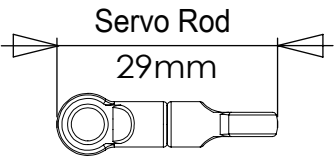

伺服機要安裝在底盤時，請先確認
伺服機的中立位置。

When installing the servo on the
chassis, please confirm the neutral
position of the servo first.

BAG
A

A5 Steering Servo

4
80400036
M3x8mm

4
85000010
Shim3x8x0.5mm

2
66480936
Aluminium Servo Mount

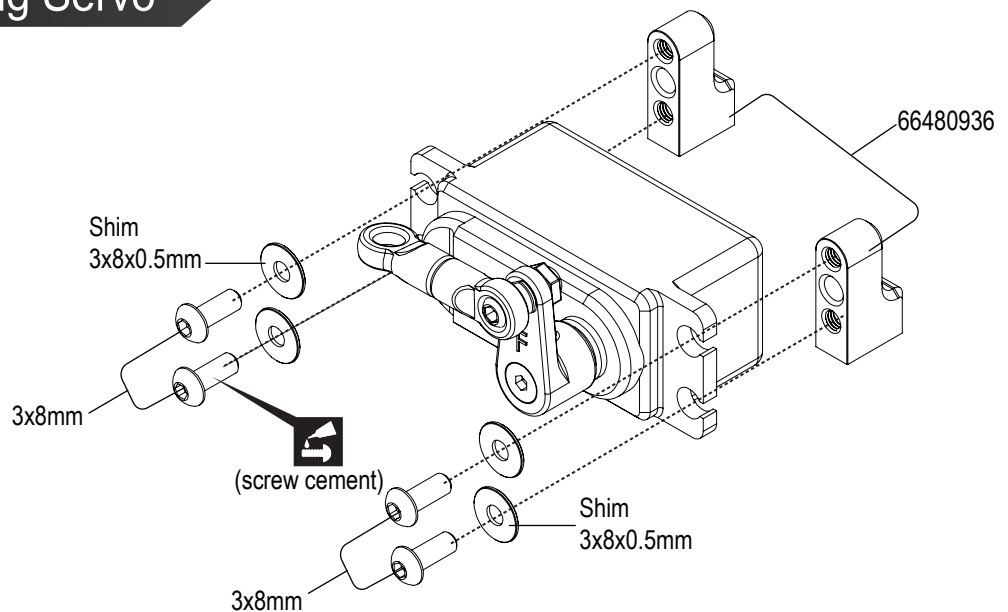



A6 Steering Servo

BAG
A

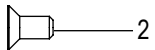

82400016
M3x6mm

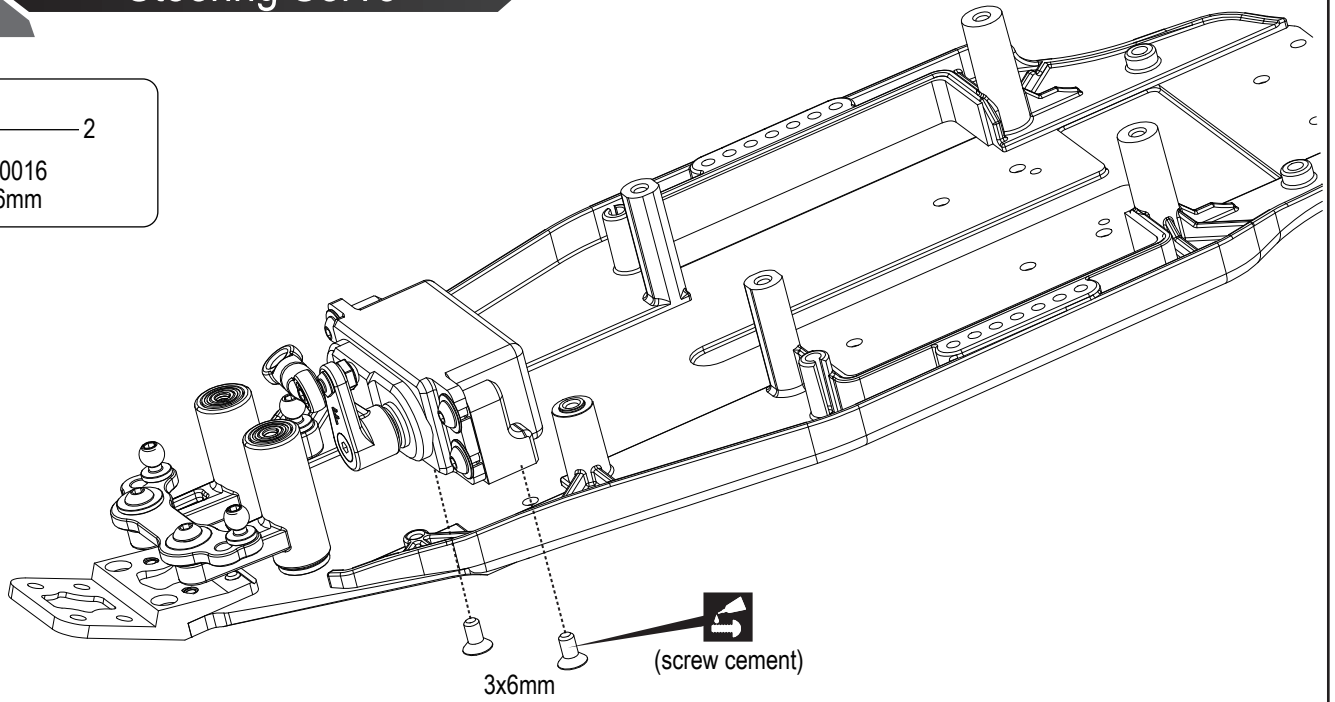

請先完成頁面A6(伺服機)在底盤上的安裝。
再前往B1頁面進行安裝。

We strongly recommend installing the steering servo now
as shown in Step A6 before proceeding with Step B1.

BAG
B

B1 Front Suspension

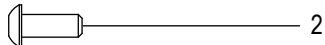

80400036 M3x8mm

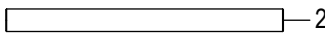

79400036 3x36.8mm Pin

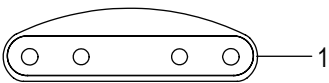

66400036

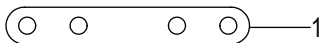

66000020

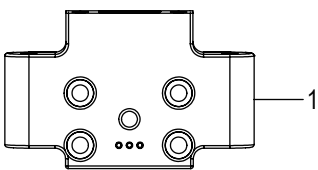

75400036
Lower Swing Arm Mount

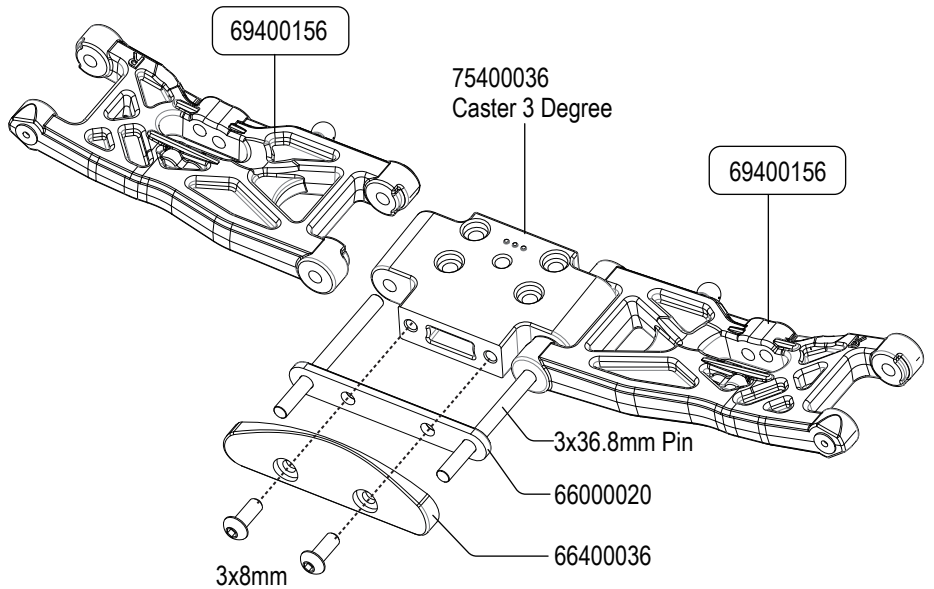

69400146

Responsive



Front Wishbone

69400156

Stable



Front Lower Gull Wishbone

B2 Front Spindle (L&R) Side

BAG
B

80400186
M2.5x6mm

80400036
M3x8mm

68430086
M4.8mmx6mm Ball Studs
Lower 0.8mm

68430076
M4.8x10mm

83400106-M3 Lock Nut

66401686
Steering Screw Stepped

89430010
5x10x4mm Ball Bearing

85440180 Shim 5x8x0.5mm

85440320
Shim 3x8x0.15mm

66481337

71400699

66480856

66401876

Corner Speed

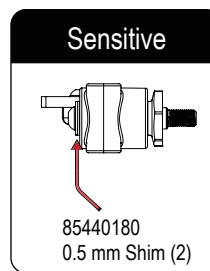
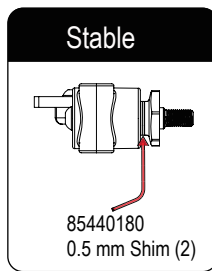

(screw cement)

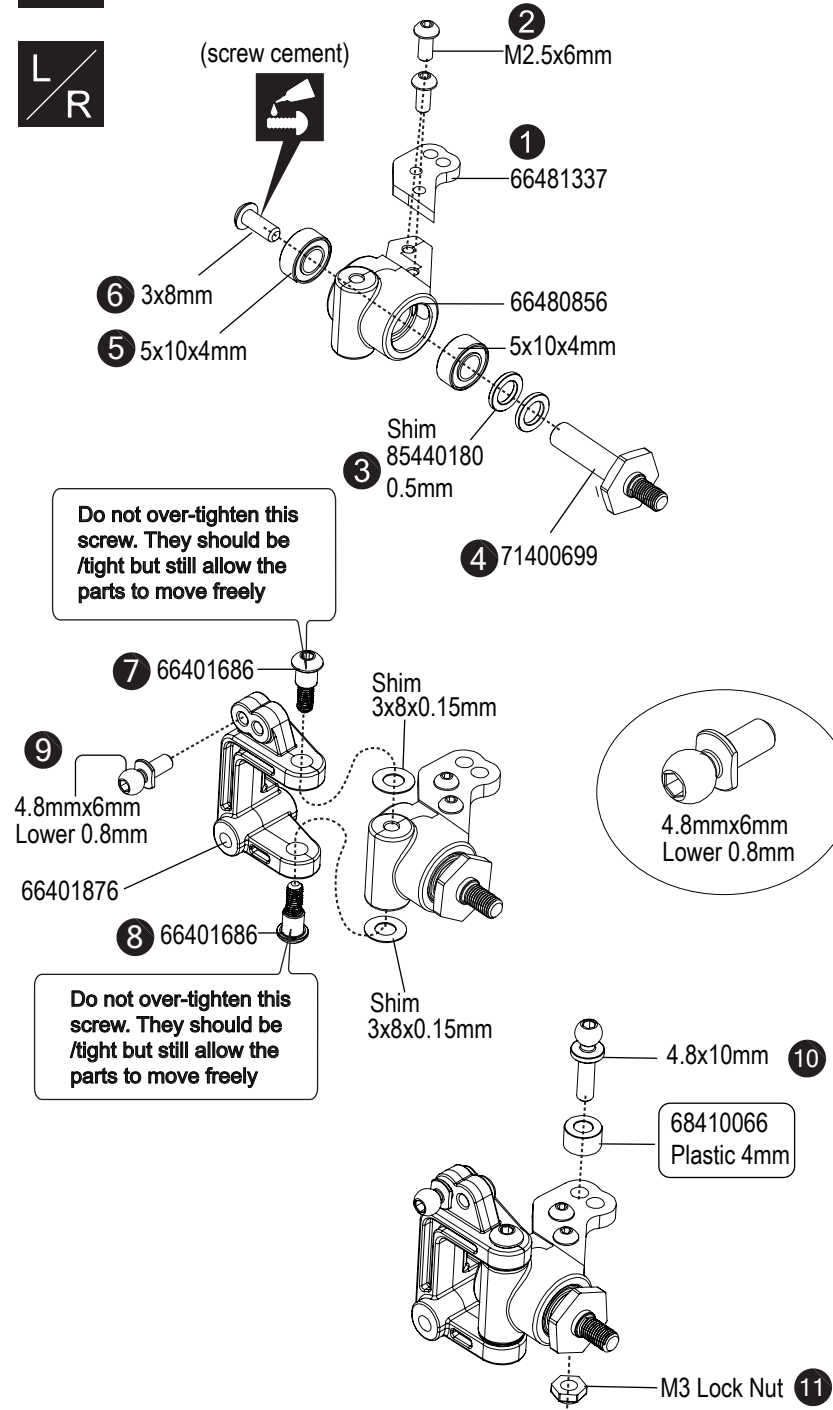

IMPORTANT
For the threading of plastic parts... "Pre-thread holes before installing steering hub."





BAG
B

B3 Front Suspension (L&R)



79400026 — 2

3x29.80mm

80400016 — 2

M2.5x4mm(5.5mm)

85440320 — 2

Shim 3x8x0.15mm

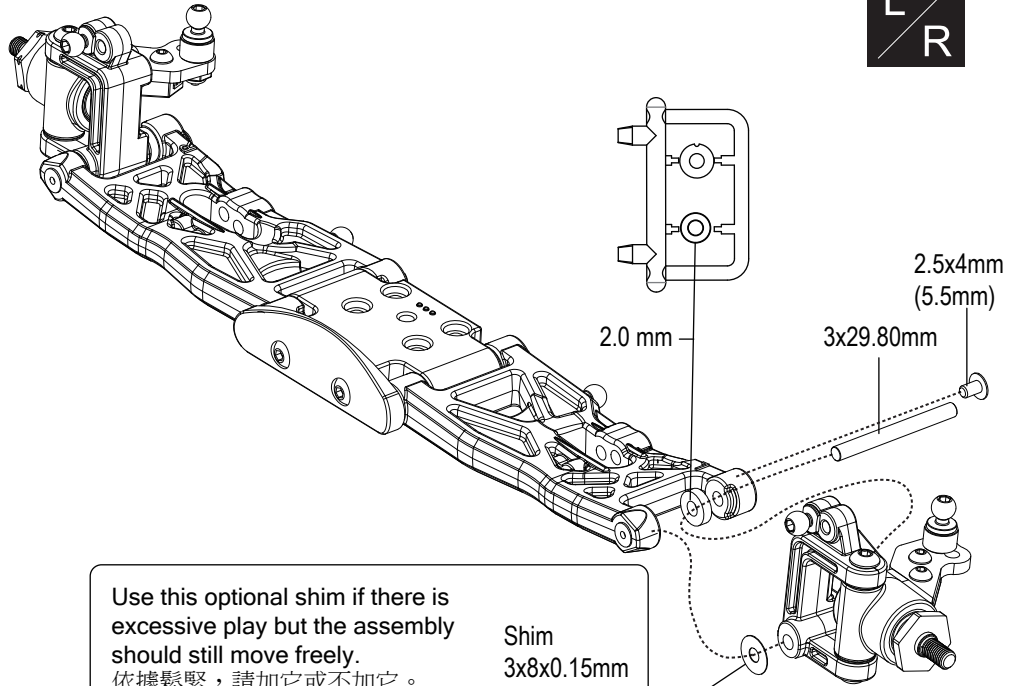

Use this optional shim if there is excessive play but the assembly should still move freely.
依據鬆緊，請加它或不加它。

Shim
3x8x0.15mm

BAG
B

B4 Front Shock Stay

82400046 M3x14mm — 4

82400026 M3x8mm — 2

80400036 M3x8mm — 4

80400046 M3x10mm — 4

68430046 M4.8x8mm — 2

85440311 3x6x2mm Silver Aluminum Spacer — 2

66481176 — 1pr

94500015 — 1

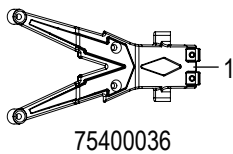

75400036

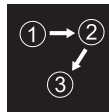

Do not over tighten

3 3x8mm

4.8x8mm

85440311 2mm

66481176

94500015

3x8mm

1

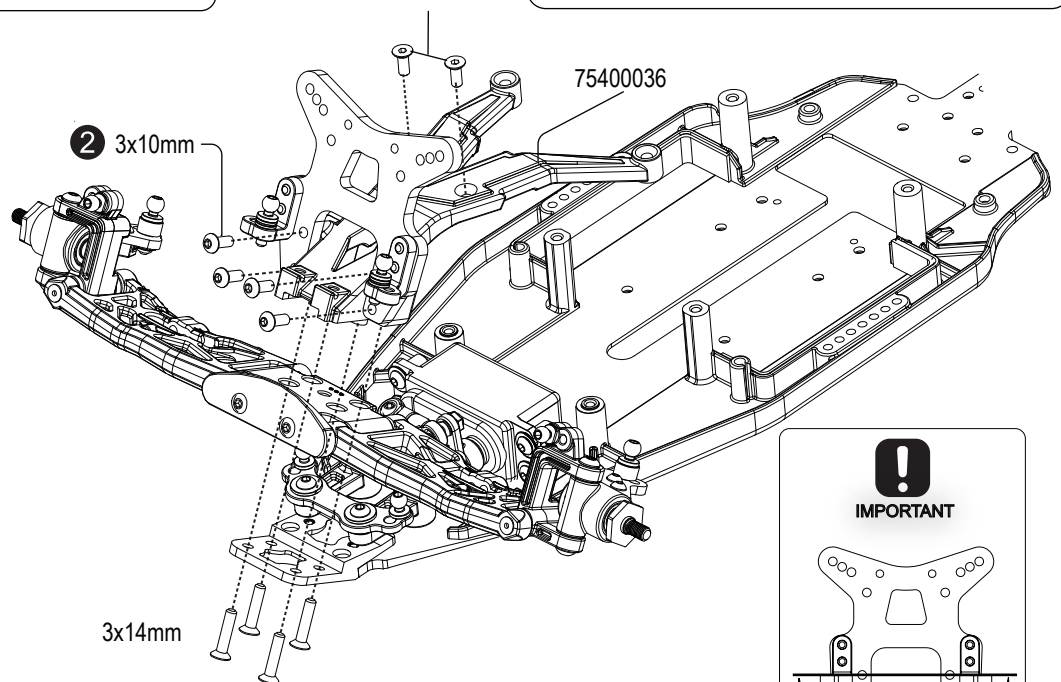

!
IMPORTANT

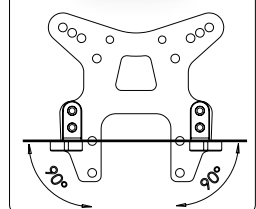



BAG
B

B5 Front Upper Turnbuckle Assembly

One side is reverse threaded.

66400346 36mm Turnbuckle — 2

82400046 M3x14mm

66400066 28.2mm Rod End — 4

66400066 28.2mm Rod End

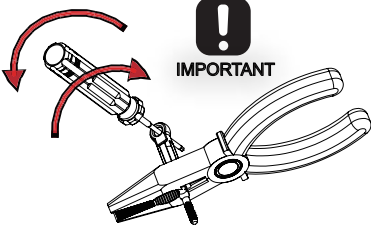
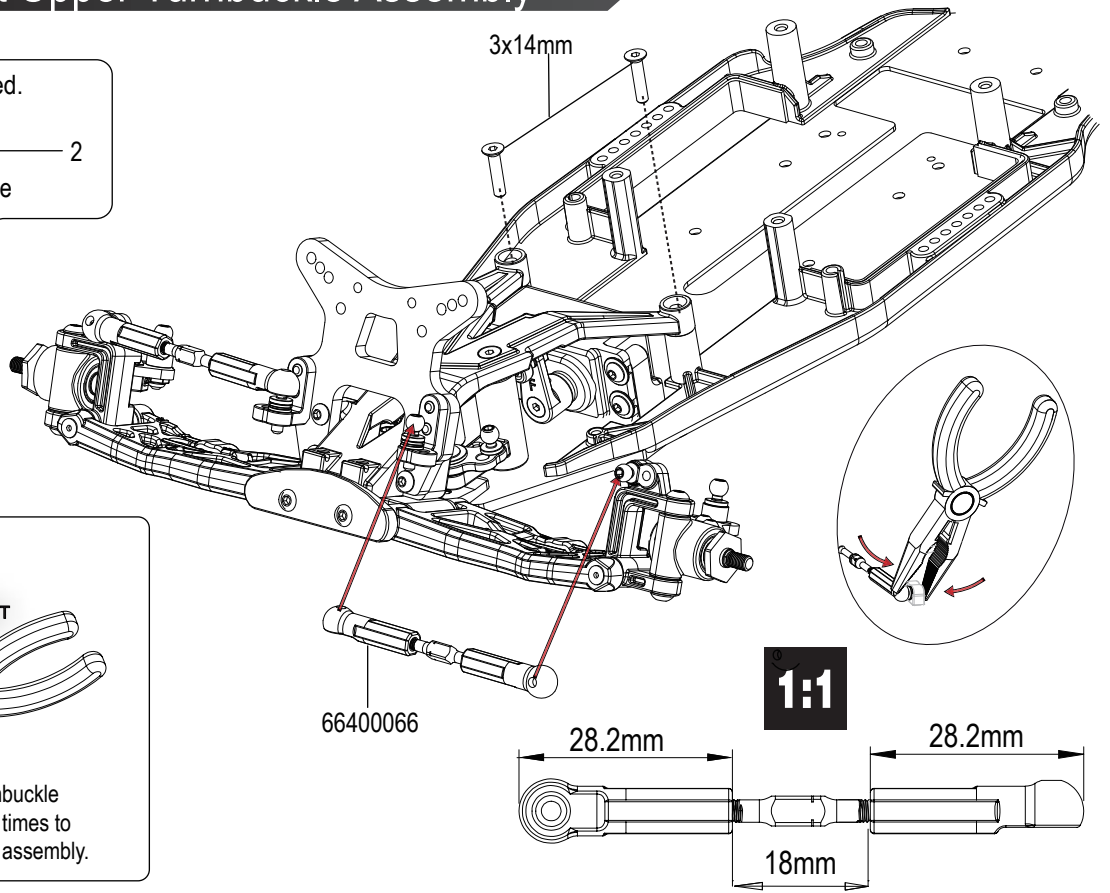

IMPORTANT

Thread and unthread the turnbuckle into the plastic rod end a few times to allow easier adjustment after assembly.

BAG
B

B6 Turnbuckle Assembly-Steering Rod

One side is reverse threaded.

66400346 36mm Turnbuckle — 2

66400066 31.3mm Rod End — 2

66400066 31.3mm Rod End

66400066 L — 1

66400066 L

66400066 R — 1

66400066 L



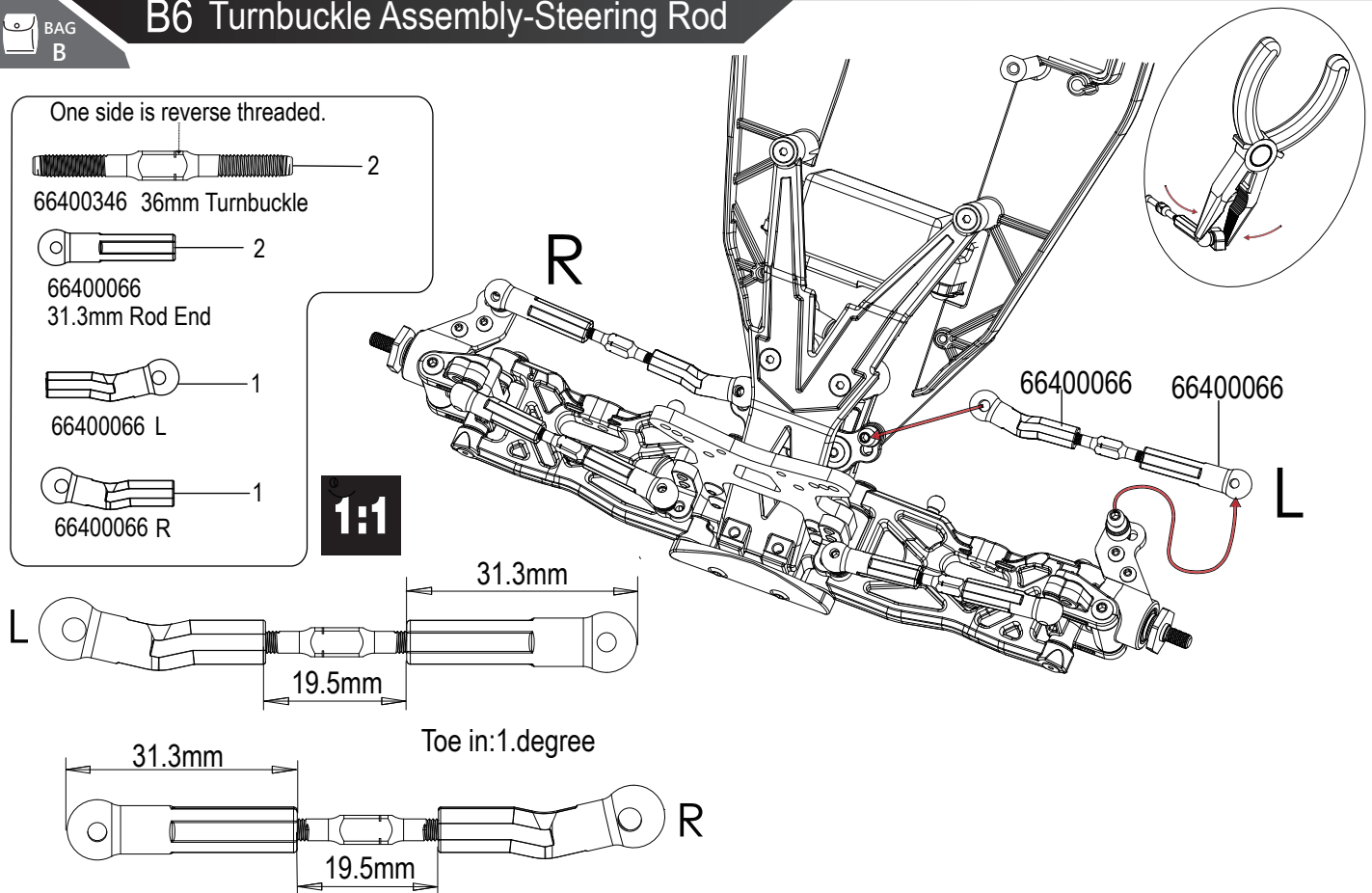

66400066 R

1:1

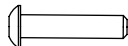
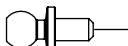
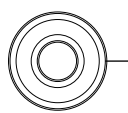

B7 Rear Hub & CVA

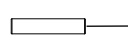
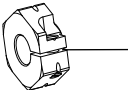
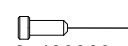
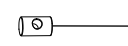
BAG
B

-  4
80400056 M3x14mm
-  2
68430066 M4.8x5mm
-  2
89430020
5x13x4mm Ball Bearing
-  2
89430030
10x15x4mm Ball Bearing
-  4
79400086 2x9.8mm
-  2
68440095 (Kit)
-  2
87400066 M2x5mm
-  2
66401096
-  2
71400701

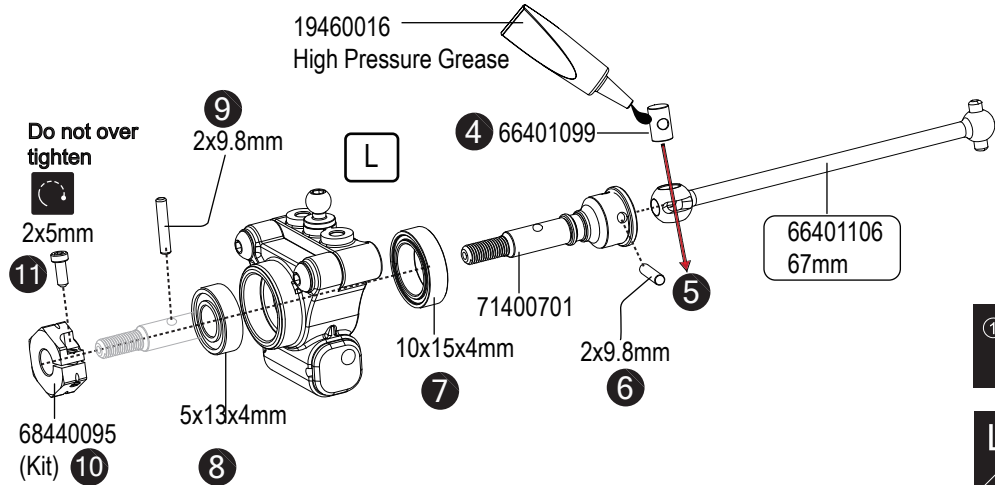
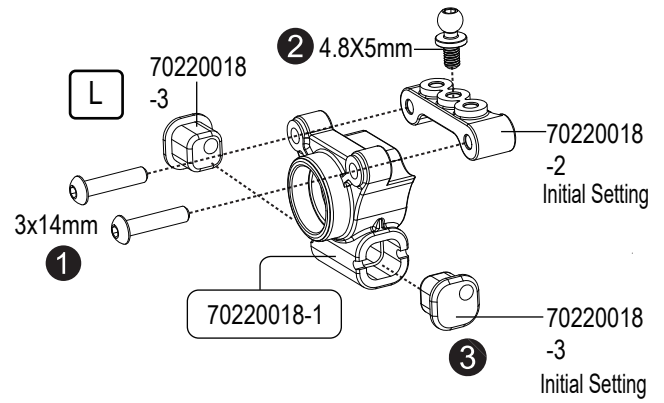
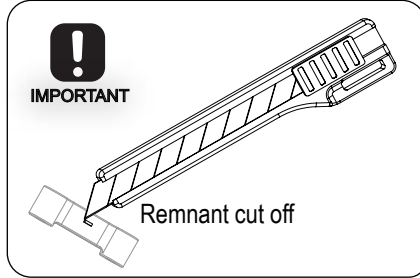

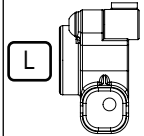
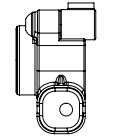
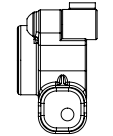
Suspension Insert	Corner Speed	
70220018-1	70220018-1	70220018-1
		
Stable	Neutral	Responsive

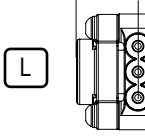
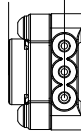
Hub Plate	Corner Speed
14.2mm	12.8mm
	
Stable	Responsive

B8 Rear Hub (L&R)

BAG
B

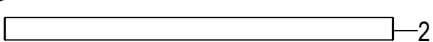
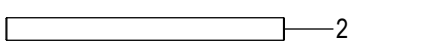
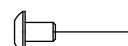
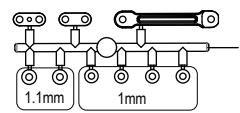
-  2
79480046
3x50.8mm
-  2
79400036
3x36.8mm
-  4
80400016
M2.5x4mm(5.5mm)
-  1
66430200
1.1mm 1mm

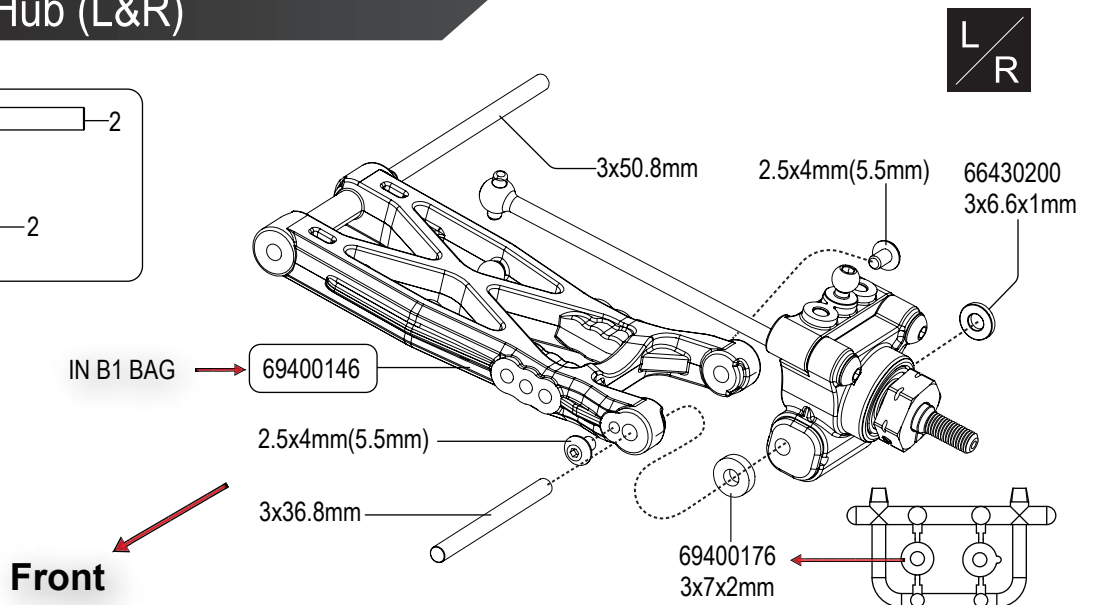

 Part Bags used.

 Assemble left and right sides the same way.

 Do not over tighten

 Assemble in the specified order



BAG
B

B9 Rear Suspension



- 4
82400026
M3X8mm
- 1
RF.
94500053/RF
- 1
RR
70220019/RR

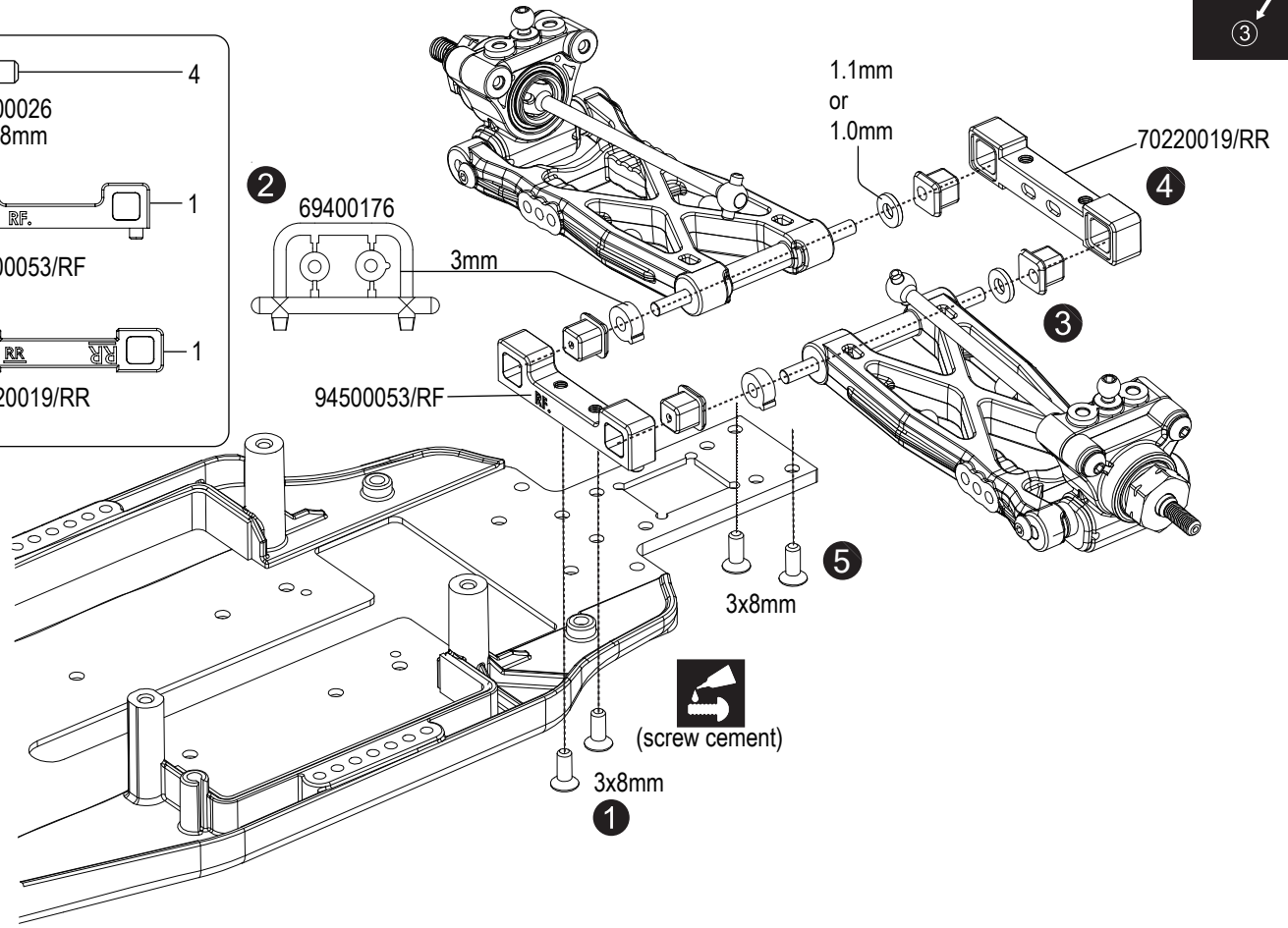

ANTI-SQUAT +1 degree

Initial Setting **TOE IN** **SQUAT**
+2.5 +1.5

Wishbone Shim selection

66430200

ANTI-SQUAT degrees

RF		RR	SQUAT
RF	RR	RR	
			0
			+0.5
			+1.5
			+2
			+2.5

TOE IN degrees

RF	RR	TOE
		+3
		+2.5
		+2
		+1.5
		+1

77500156

Use combinations of these 3 inserts to adjust ANTI-SQUAT and TOE IN

C1 Gear Differential

BAG
C

4
8000021
M2.5x8mm

2
85440170
5x8x0.8mm Shim

2
31450016 O-ring

4
85440160
4x10x0.15mm Shim

2
85400016 3.5mm
E-Clip

2
66480356

2
66480336 14T

4
66480336 9T

2
66481366

1
66480366

1
74480036

2
89430030
10x15x4mm Ball Bearing

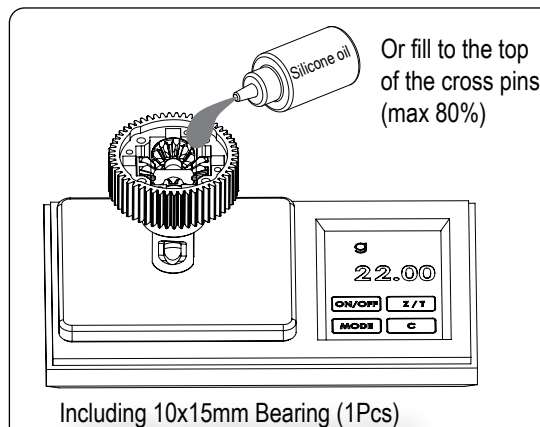
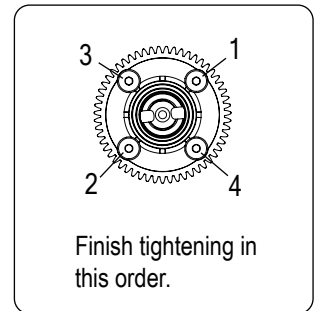
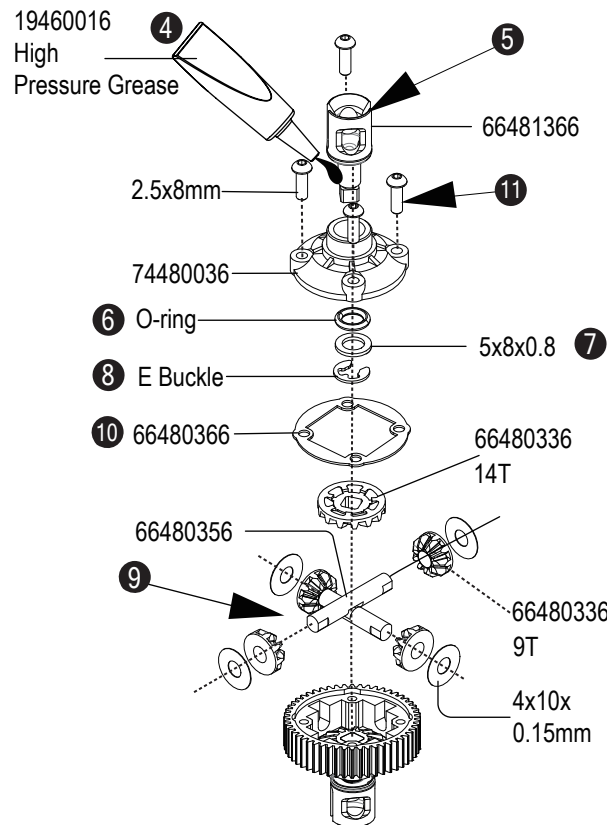
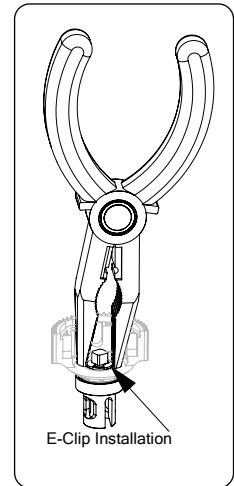
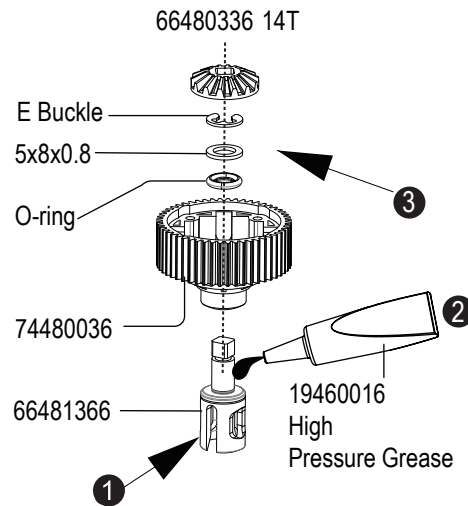
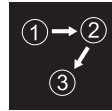

Silicone oil	
Low Traction	3000cst
Medium High Traction	5000cst
Super High Traction	7000cst

C2.1 Transmission Assembly



BAG
C

OP

66402086
34T Aluminium
Idler Gear

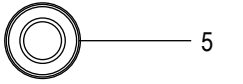

5
89430010
5x10x4mm Ball Bearing



1
66480236-5x18mm
Aluminium Idler Shaft



4
80400196
M3x18mm



1
80400066
M3x20mm

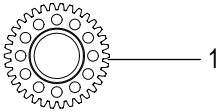

1
66402086
34T Aluminium Idler Gear

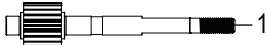

1
66480646 20T

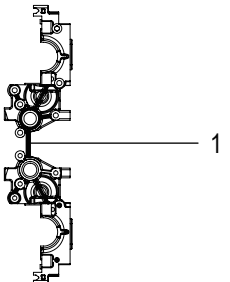

1
70220021

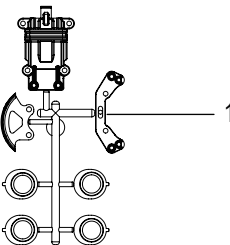

1
70220020

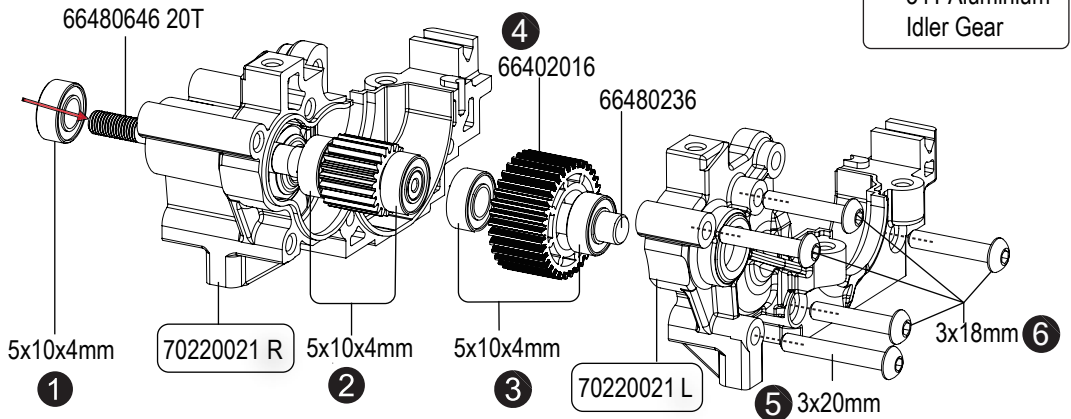

!
Tighten the screws equally
but do NOT
tighten them completely.

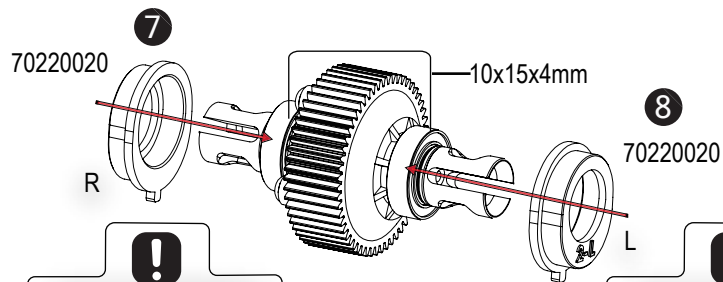
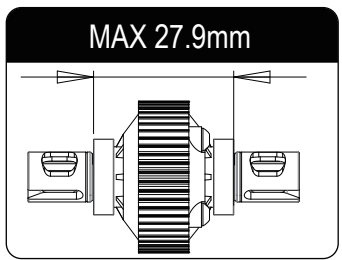
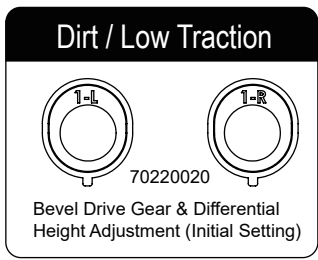
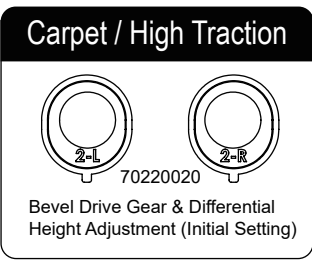

!
NOTE ORIENTATION
Numbers must have
the same orientation
on each side

!
NOTE ORIENTATION
Numbers must have
the same orientation
on each side

C2.2 Transmission Assembly

BAG
C

9

M3x3mm Set Screw

75400017

70220011 / 1.3mm

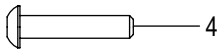

4
80400057
M3x15mm

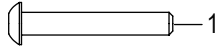

1
80400066
M3x20mm



1
82400066 M2.5x8mm

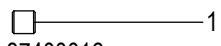

1
87400016
M3x3mm Set Screw

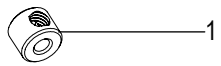

1
75400017
Sway Bar Stop Collar



70220011 / 1.3mm

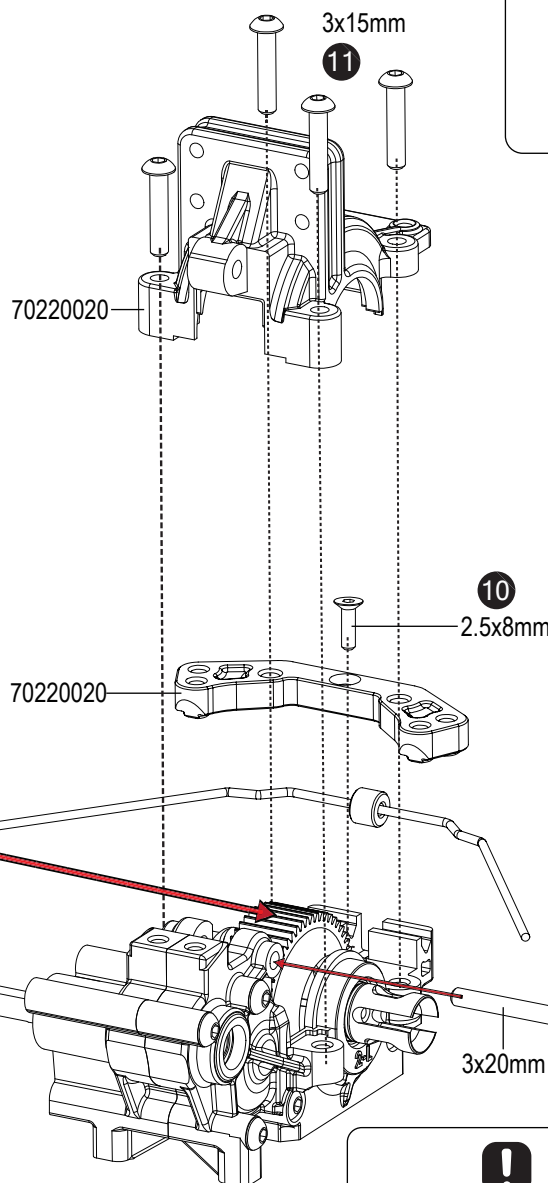
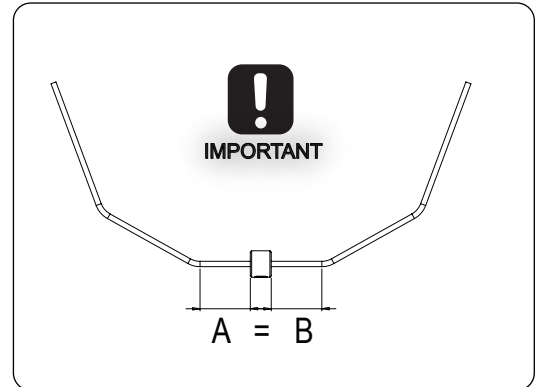
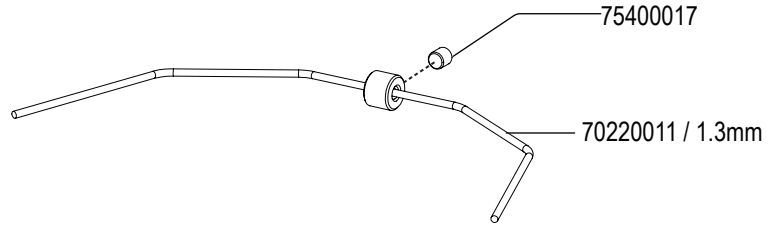

19460016
High
Pressure Grease

!
Tighten the screws equally
but do NOT
tighten them completely.

C3 Transmission Assembly

BAG
C

3
82400036
M3x12mm

1
83400036-M4 Lock Nut

1
66402696
S1 support piece

1
66402666
S1 Slipper Spring

1
94500036
PRS1V4
Carbon Motor Plate

1
66400466
Vented Slipper Plate

1
66480596
77T

1
74430016
Vented Slipper Plates

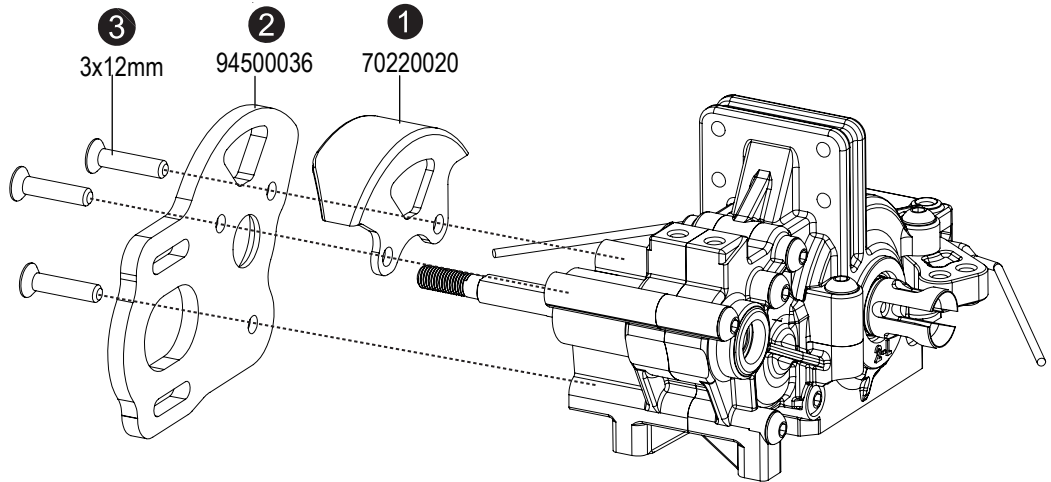

Tighten the lock nut for the slipper spring to 0mm for first drive. Adjust according to track conditions and motor turn.

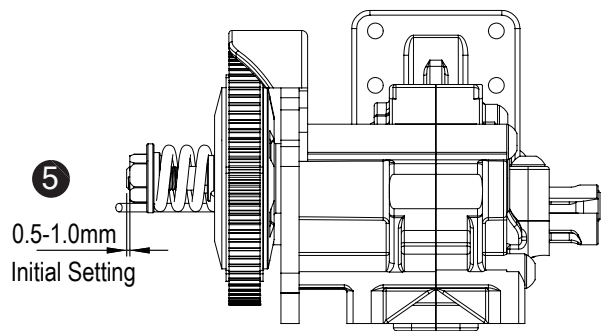

Carpet / High Traction

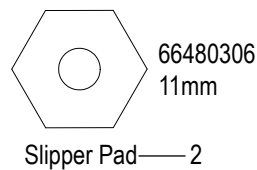

Slipper Pad — 2

Dirt / Low Traction



Slipper Pad — 2

M4
Lock Nut

66402696

66402666

66400466

Slipper
Pad

66480596
77T

66480306
11mm

74430016

4



Assembly Video



Part Bags used.



Assemble in the specified order



BAG
C

C4 Rear Shock Stay

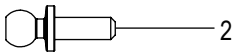

68430046
M4.8x8mm Ball Studs

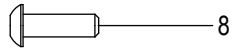

80400046
M3x10mm

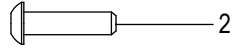

82400036
M3x12mm

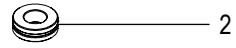

85440311
3x6.0x2mm Aluminum Spacer

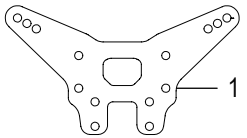

94500013

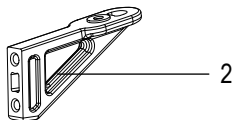

68480106

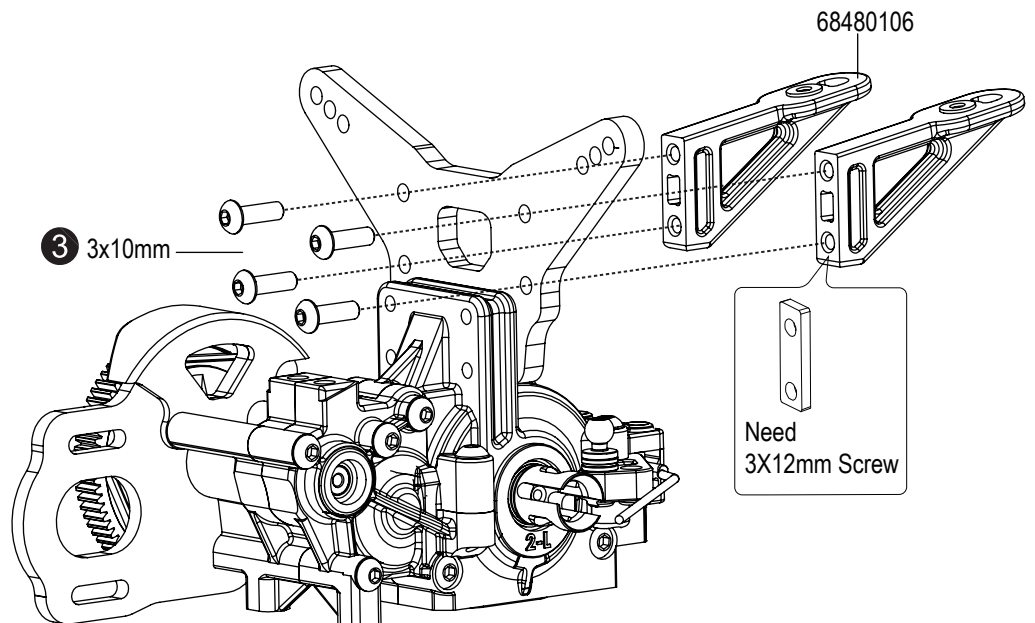
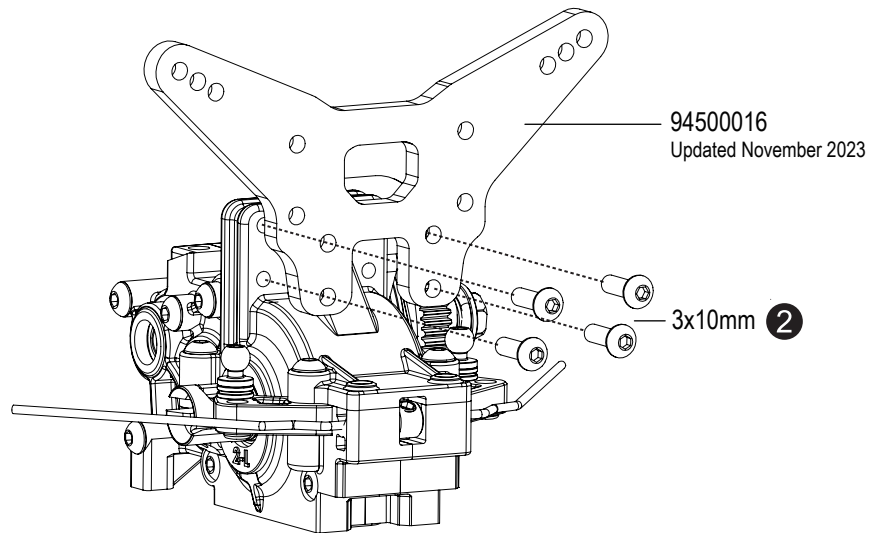
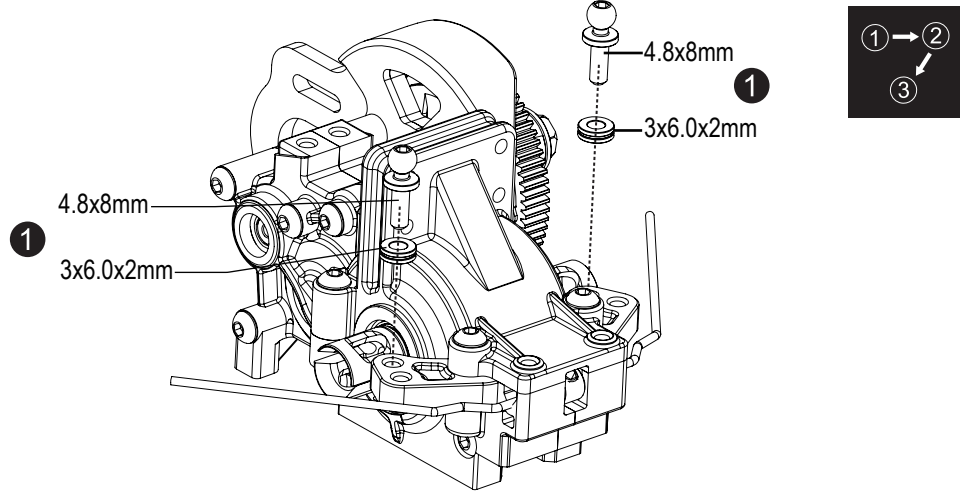

C5 Rear Gear Box

齒輪箱裝入底盤時 請先完成馬達安裝。
 Note: complete installation of the motor to the gearbox before installing gearbox to chassis.

80400036
 M3x8mm

85440301
 3x6x0.5mm Shims

85440240
 M3 Antislip Shims

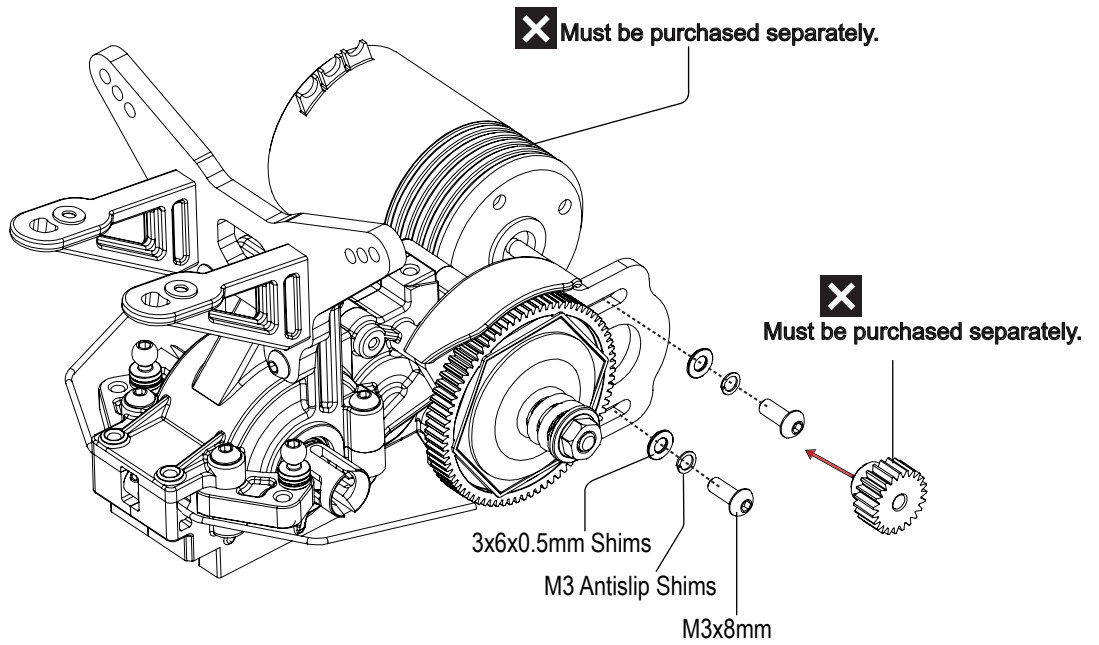

C6 Anti-Roll bar Balls

82400026 M3x8mm

M3x6mm Set Screw
 78400026



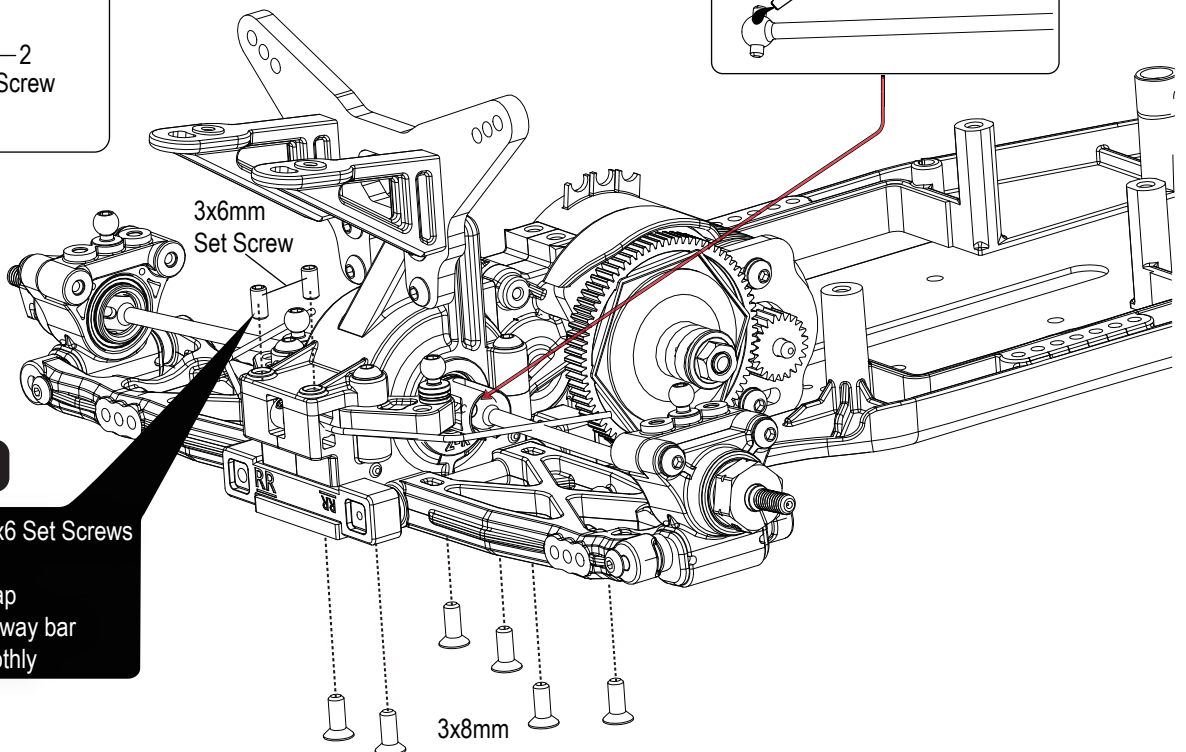

19460016
 High Pressure Grease

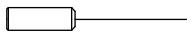

Adjust the M3x6 Set Screws and stopper to remove any gap but allow the sway bar to swivel smoothly

C7 Anti-Roll Bar Balls

BAG
C

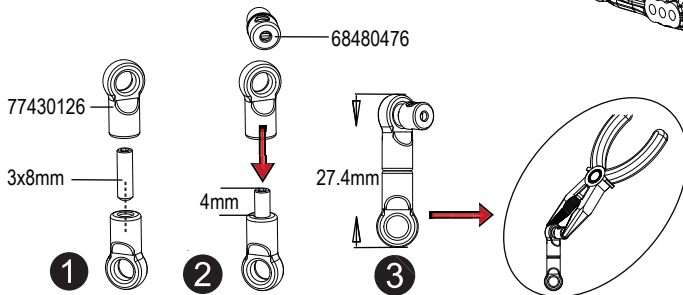
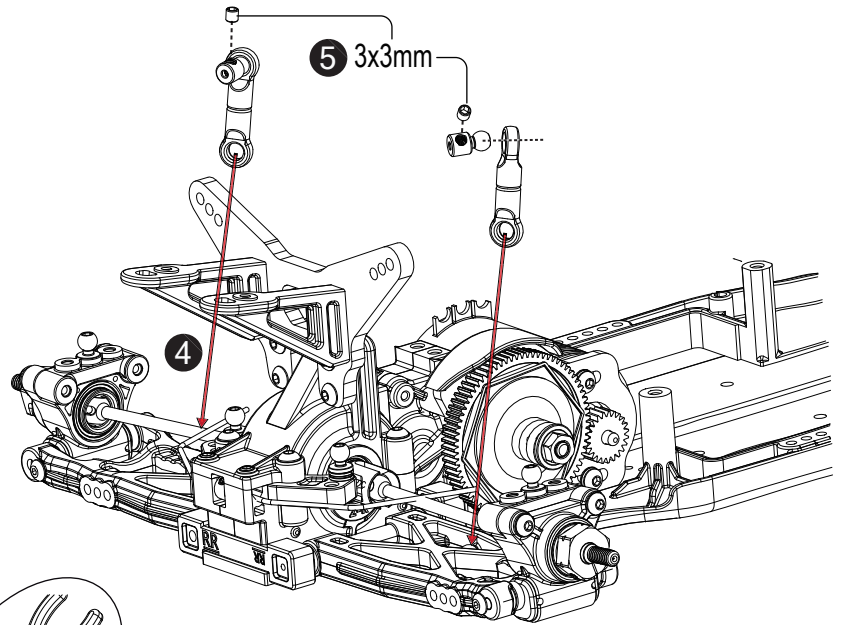

-  2
87400096
Set Screw 3x8mm
-  2
68480476
Anti-Roll bar Balls 1.7mm
-  4
77430126
-  2
87400016
Set Screw 3x3mm



C8 Rear Upper Rod-Turnbuckle Assembly

BAG
C

One side is reverse threaded.

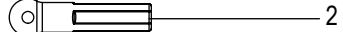
-  2
66400346
36mm Turnbuckle
-  2
66400066
28.2mm Rod End
-  2
66400066
31.3mm Rod End

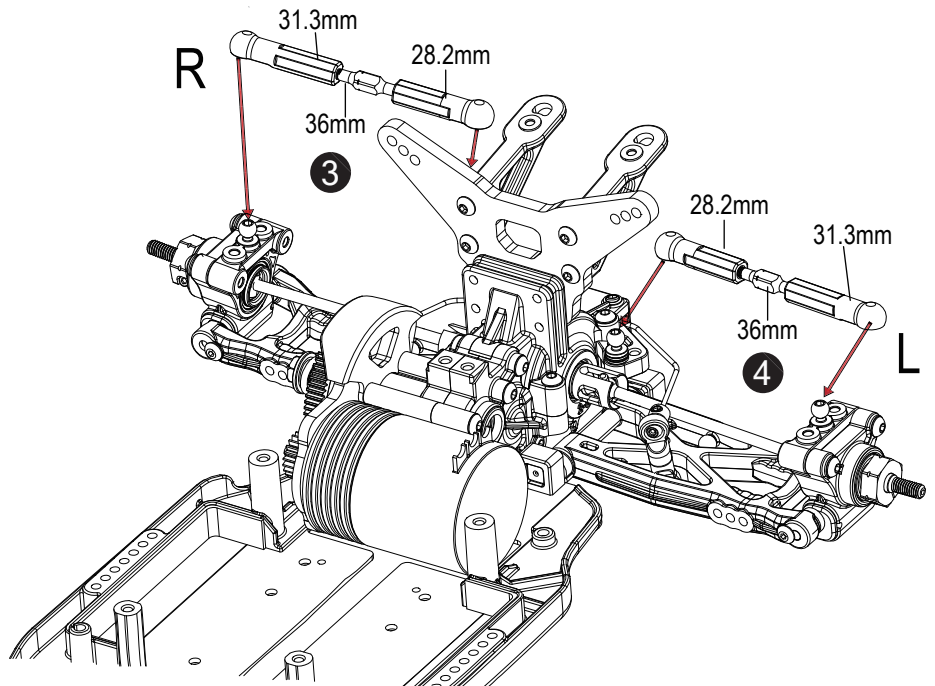

1:1

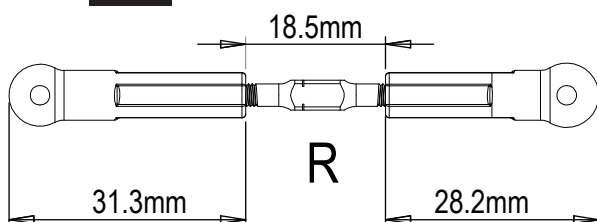

1

2

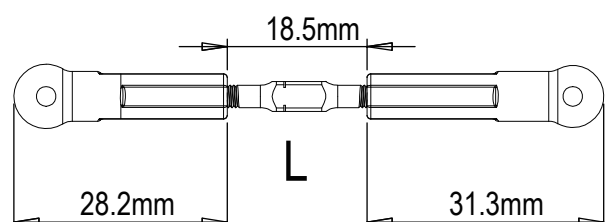

D1.1 Front & Rear Shock Assembly



BAG
D

!
IMPORTANT

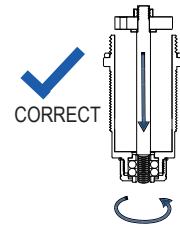
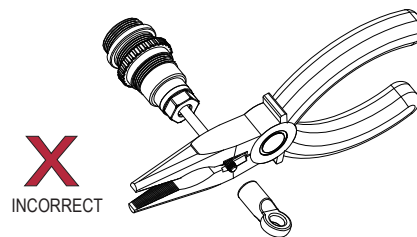
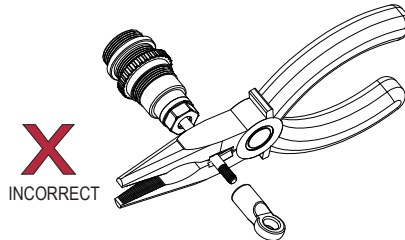
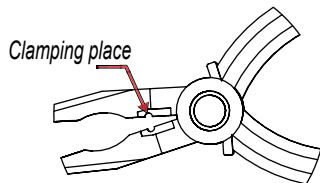
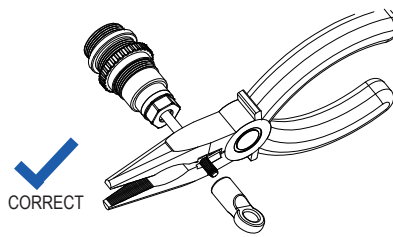

Twist the shock rod through the lower shock body assembly.

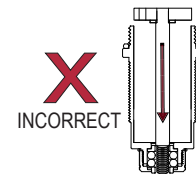

EXTREMELY IMPORTANT

Do not push the shock rod straight through the lower shock body assembly; O-ring damage may result.



Rear Buildx2
Front Buildx2
Initial setting

68410066

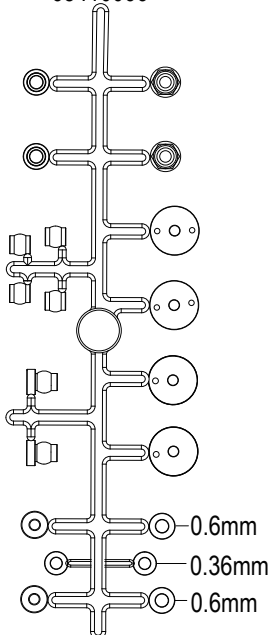

m2.5 Do not over tighten (screw cement)

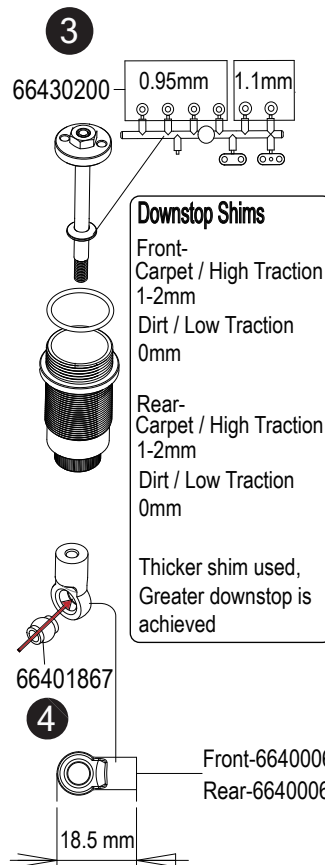
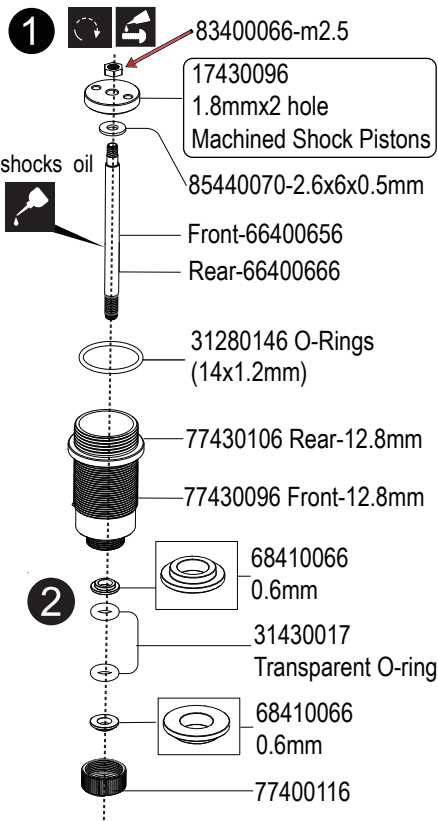

D1.2 Front & Rear Shock Assembly



BAG
D

Front Build x2
Rear Build x2

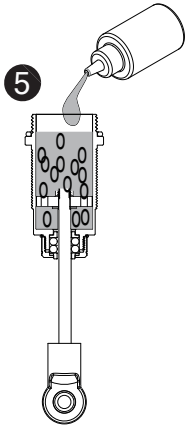

Initial Setting

Front shocks	oil	Rear shocks	oil
↑ 20°C	500Cst	↑ 20°C	450Cst
↓ 20°C	450Cst	↓ 20°C	400Cst

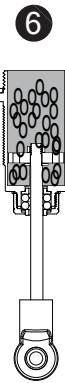

Slowly move up and down to remove air bubbles.

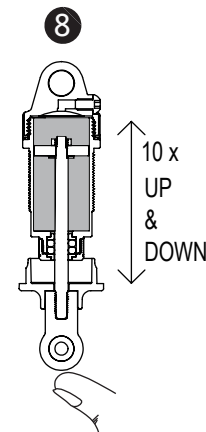
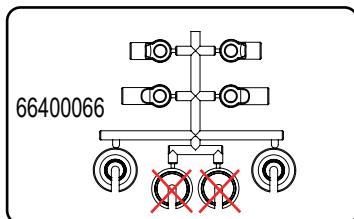
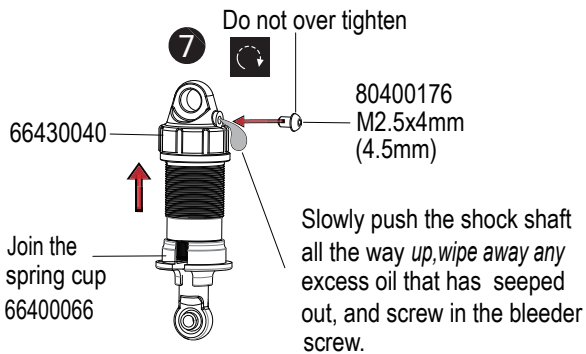

10 x push the shaft up and down.

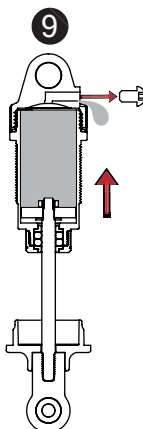

Untighten the screw.

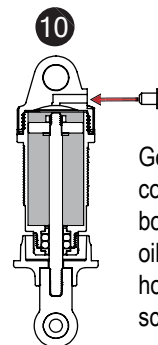

Gently push the shock shaft completely into the shock body. Wipe away any excess oil that flows through the hole in the shock cap and screw in the bleeder screw.

D1.3 Front & Rear Shock Assembly



BAG
D

Front Build x2 Initial setting

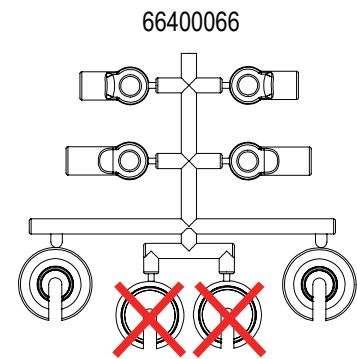
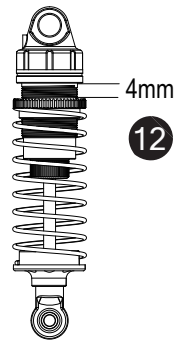
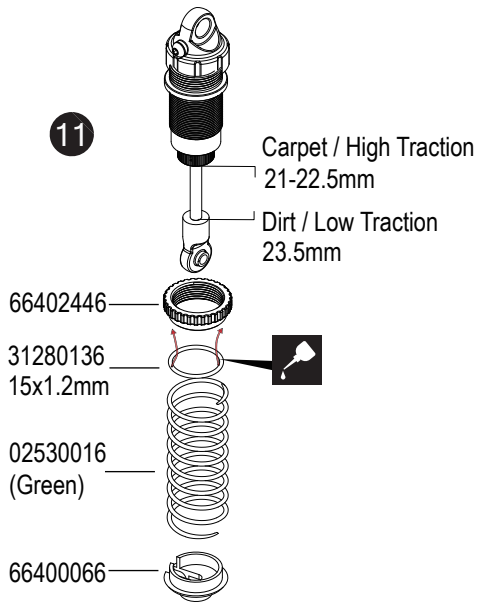

Rear Build x2 Initial setting

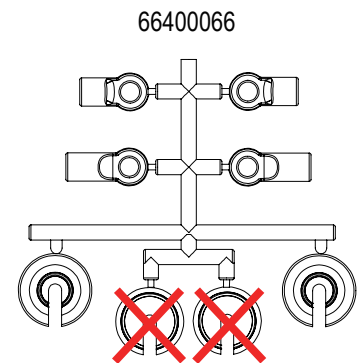
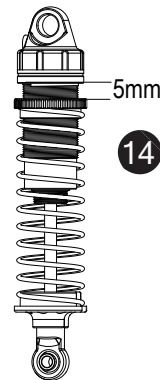
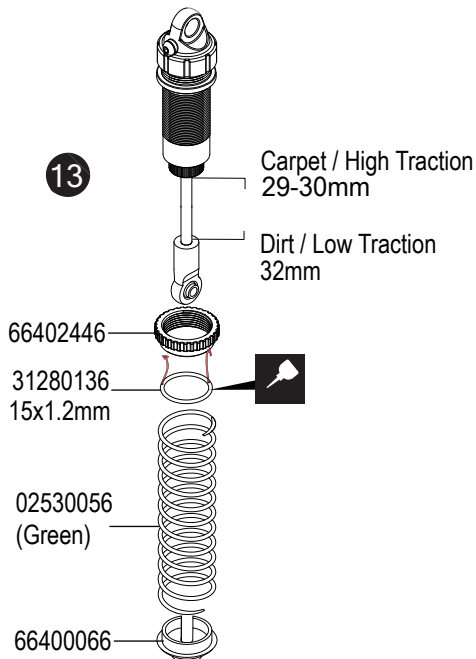

Option

71530016-Type R Front Shock Spring Set			
PART NO:	Color	kg mm	lbs/in
02500096	Transparent	0.053	2.97
02500106	Blue	0.058	3.25
02500146	White	0.061	3.42
02500116	Red	0.063	3.53
02500126	Yellow	0.068	3.81
02530016	Green	0.075	4.20
02530026	Black	0.080	4.48
02530036	Blue Red	0.085	4.76
02530046	White Yellow	0.090	5.04
02530116	Green Black	0.098-(RT)	5.88-(RT)

71530026-Type R Rear Shock Spring Set			
PART NO:	Color	kg mm	lbs/in
02500056	Transparent	0.030	1.80
02500066	Blue	0.035	2.10
02500136	White	0.037	2.22
02500076	Red	0.040	2.40
02500086	Yellow	0.045	2.70
02530056	Green	0.050	3.00
02530066	Black	0.055	3.30
02530076	Blue Red	0.060	3.60
02530086	White Yellow	0.065	3.90
02530126	Green Black	0.073-(RT)	4.50-(RT)



Part Bags used.



Apply oil.







Assemble in the specified order.

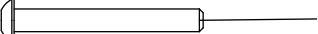

BAG
D

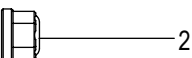

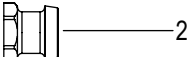
D2 Front Suspension

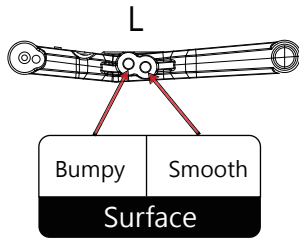
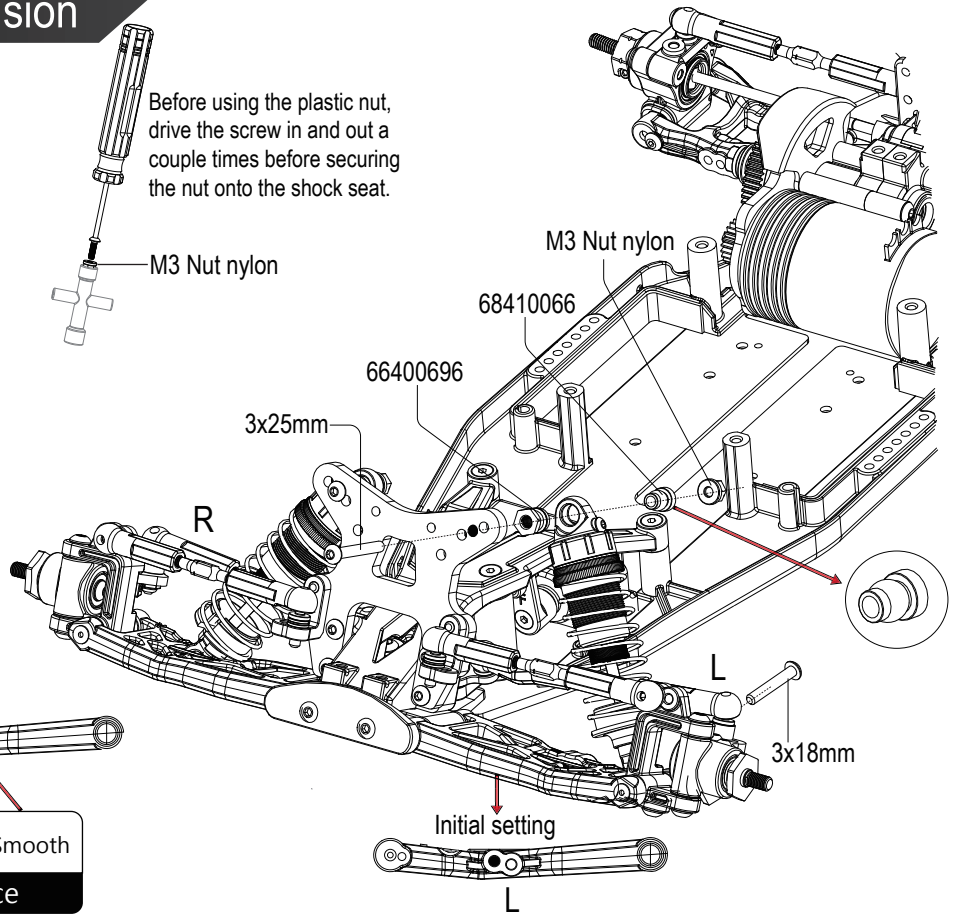
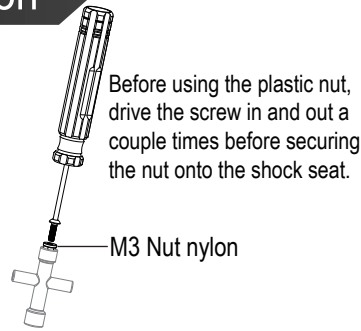
-  2
80400076 M3x25mm
-  2
80400196 M3 x18mm
-  2
68410066 M3 Nut nylon
-  2
68410066
-  2
66400696

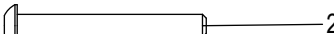
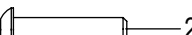
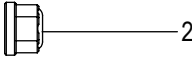
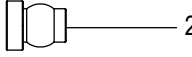

BAG
D

D3 Rear Suspension

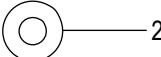
-  2
80400076 M3x25mm
-  2
80400057 M3x15mm
-  2
68410066 M3 Nut nylon
-  2
-  2
-  2
85440211 Shim3x8x1mm

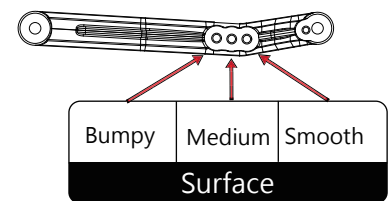
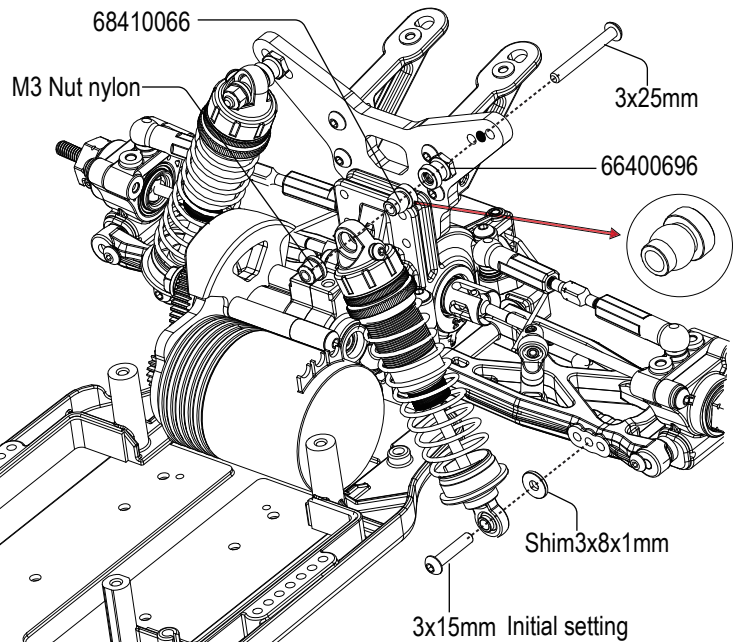

D4 Motor

BAG
D

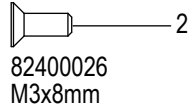
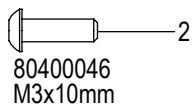

Hard Responsive

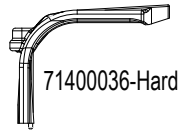

Soft Stable



0 Stable+



2 3x10mm

1 3x8mm

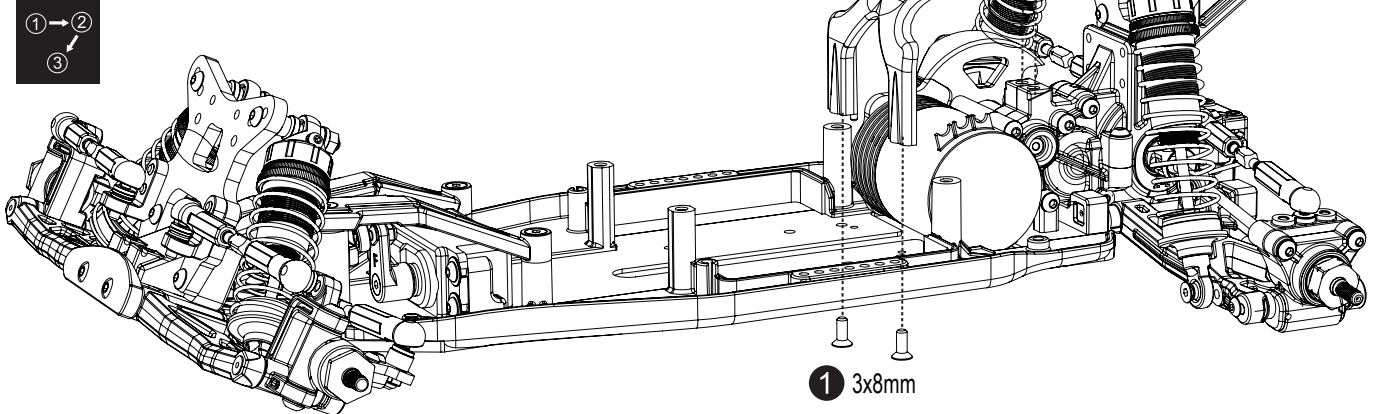

D5 Battery Plate

BAG
D

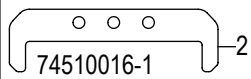
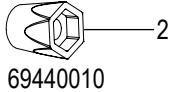
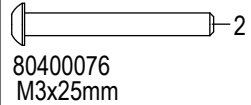
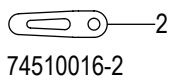
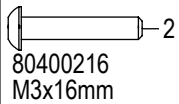
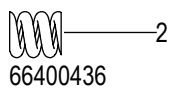
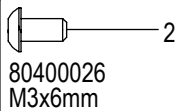

3x16mm

74510016-2

74510016-1

66400436

3x6mm

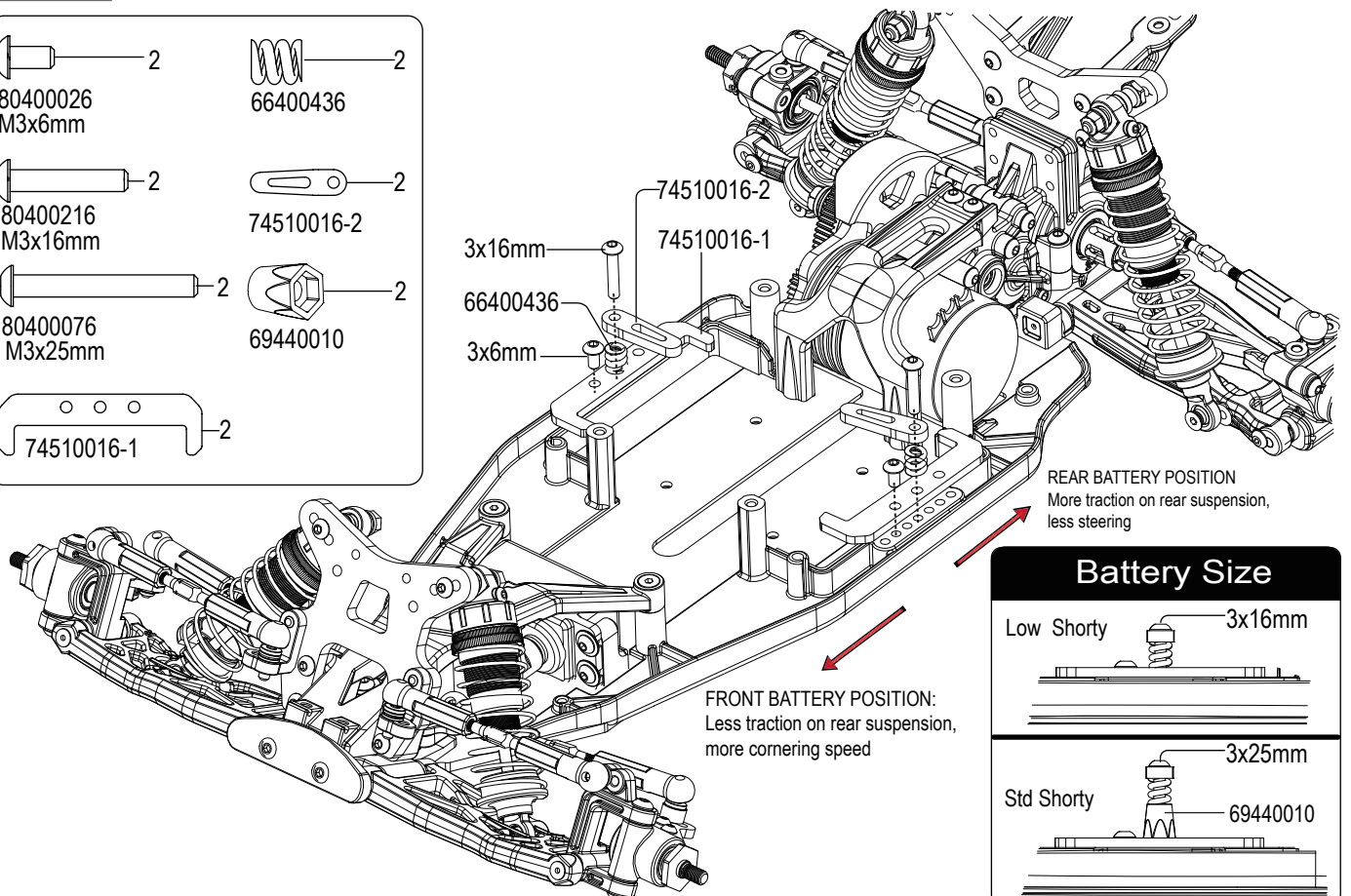

REAR BATTERY POSITION
More traction on rear suspension,
less steering

FRONT BATTERY POSITION:
Less traction on rear suspension,
more cornering speed

Battery Size

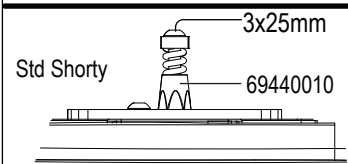
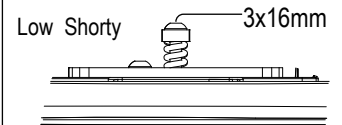



D6 Battery Plate

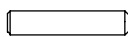

BAG
D

 2
87400036 M3x16mm Set Screw

 2
66481446
Battery retaining nut +oring(Black)

 2
80400046 M3x10mm

 2
82400026 M3x8mm

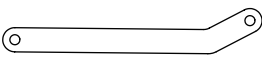
 2
91400016
(Std Shorty) Battery Size

 1
73400066

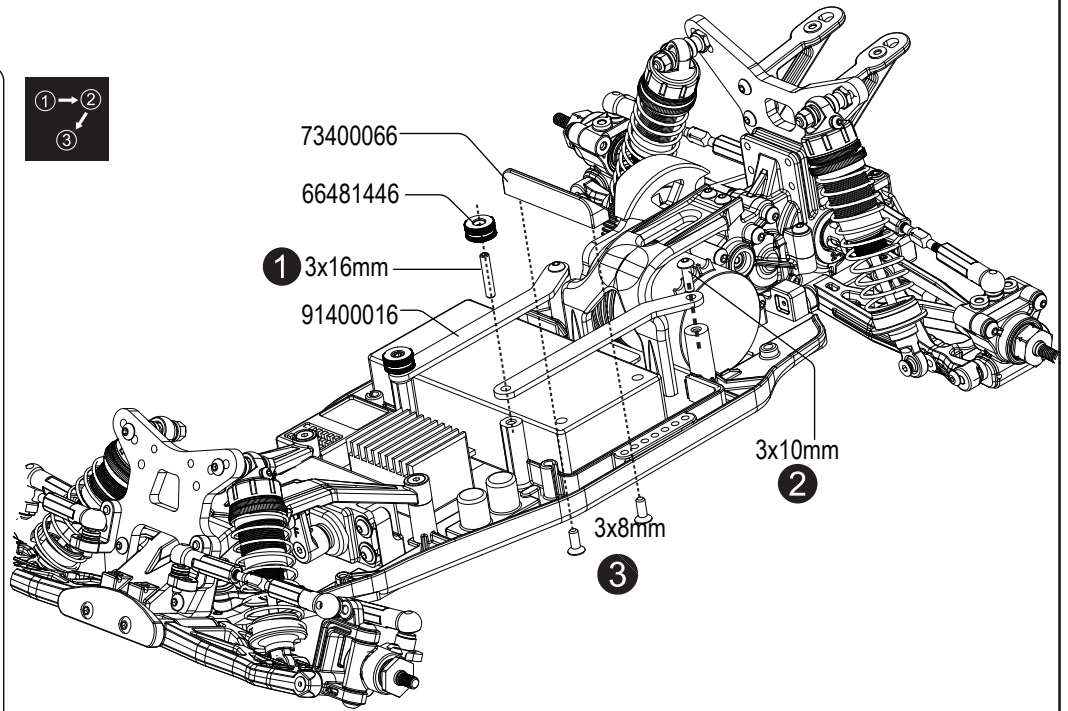

Battery Selection

Battery Size

Std Shorty

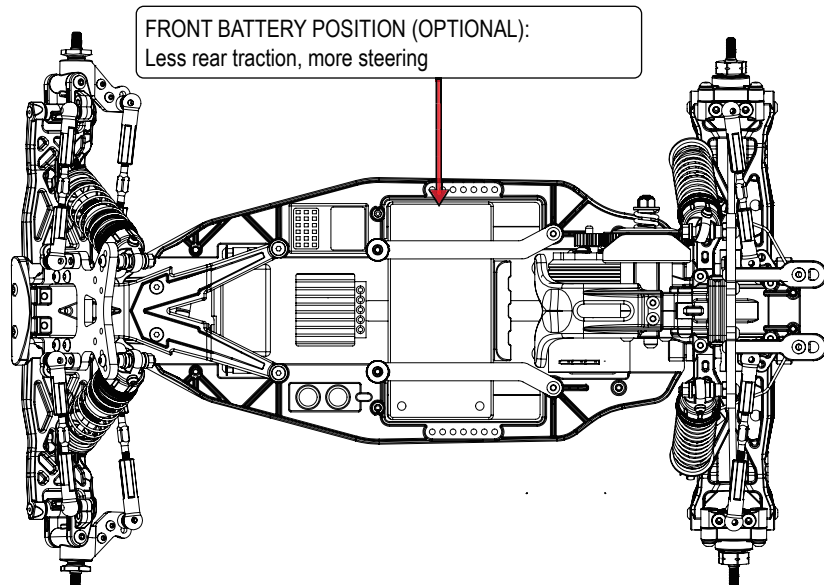
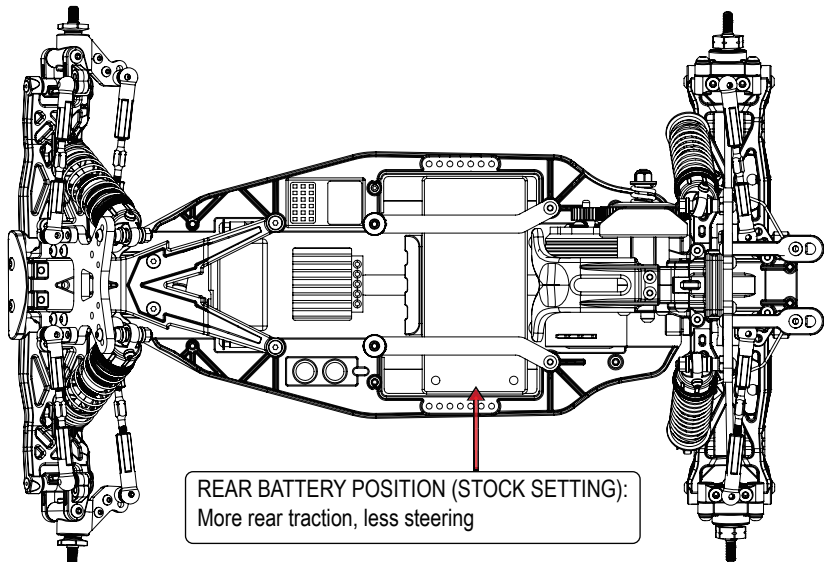



BAG
D

D7 Body

66430241 PRS1 V4 Sticker



- 2
82400026 M3x8mm
- 2
82400106 M3x10mm
- 4
83400076 M4 Nut
- 2
68480036
- 2
99400056 Velcro Tape
- 1
98400016 Antenna Tube

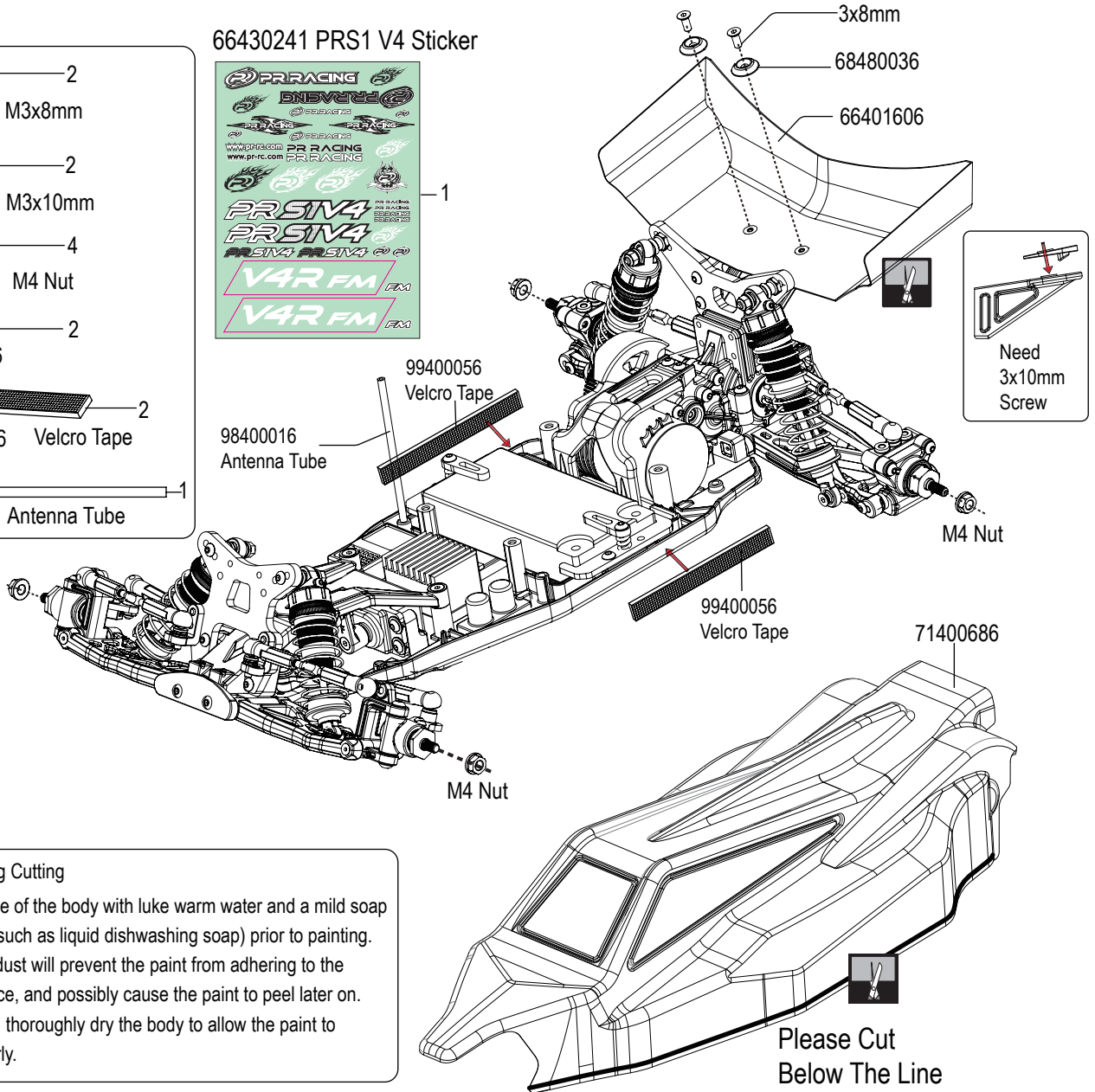

Body and Wing Cutting

Wash the inside of the body with luke warm water and a mild soap or detergent (such as liquid dishwashing soap) prior to painting. Oil residue or dust will prevent the paint from adhering to the painting surface, and possibly cause the paint to peel later on. After washing, thoroughly dry the body to allow the paint to adhere properly.

Tires

34430018
2WD Front Wheel Counterweight Ring

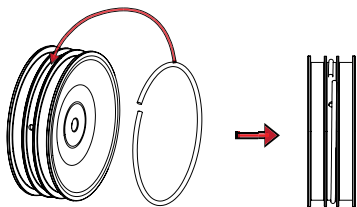

1. Add more weight to the front of the chassis to increase steering response.
2. Increase the rotational inertia of the front wheels for more precise in-air control during jumps.

Option Parts

Mounting Tires

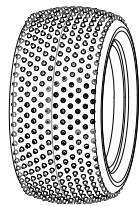

Place the tire insert into the tire and tire onto the wheel.
Tire and insert (Sold separately)
CA(Cyanoacrylate) glue sold separately.

Wheel Installation

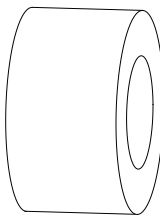

kit 68400316 Rear Wheel
kit 68400296 Front Wheel

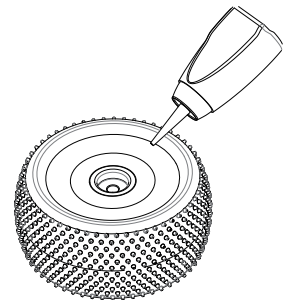
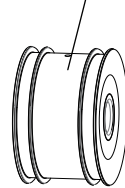

Pull the sidewall of the tire slightly away from the rim and apply CA(Cyanoacrylate) glue in between the tire bead and rim





PRSI (FM) V4-R

ITEM NO: 75400056

Name _____

Date _____

Track/City _____

Event _____

Front Suspension

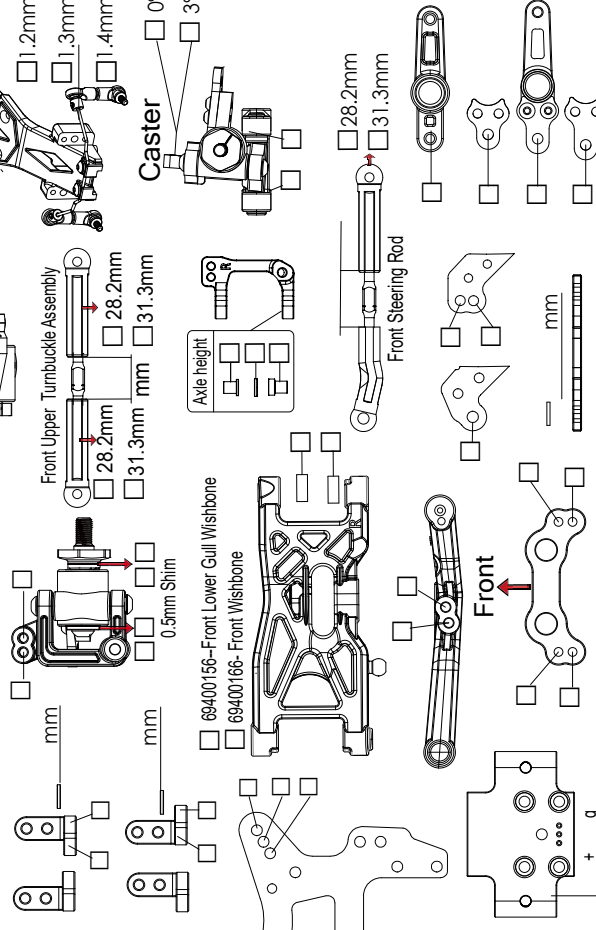

Rear Suspension

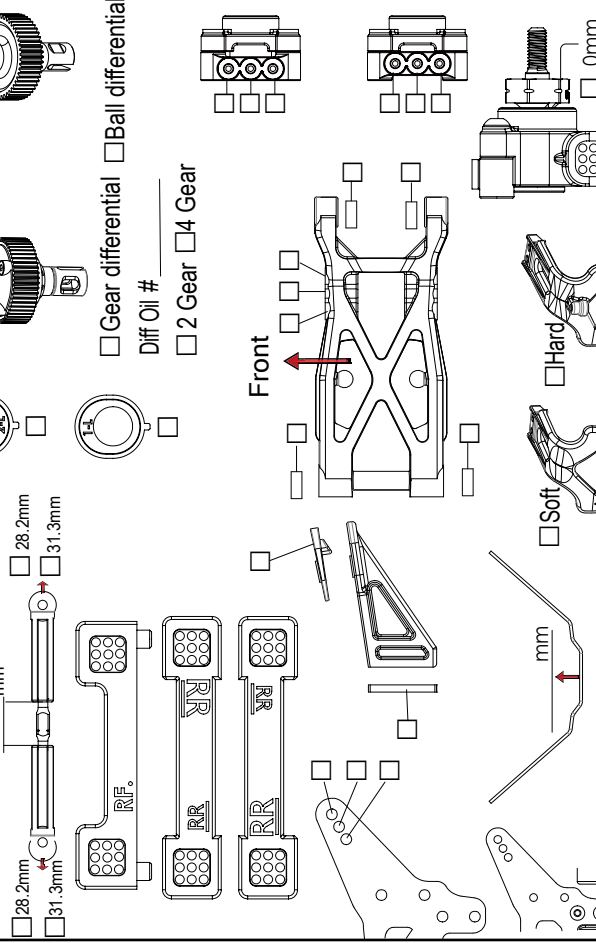

Camber	mm
Ride Height	mm
TOE In Out	mm
Type R	
Shock Spring	

Camber	mm
Ride Height	mm
TOE In	mm
Type R	
Shock Spring	









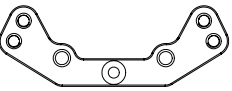
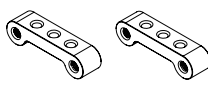
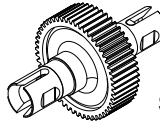
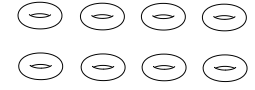
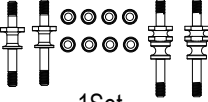
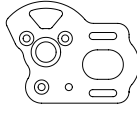
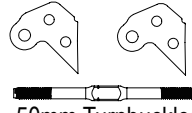

Front	Motor	Body	Light
Tire	Spur Gera T	Standard	
Inserts	Pinion T	Wishbone Rear	High Hardness Graphite <input type="checkbox"/> Medium Hardness <input type="checkbox"/>
Wheels	Esc	Ride Height	F R
Rear	Servo		
	<input type="checkbox"/> Std. Profile Servo <input type="checkbox"/> Low Profile Servo		
Tire	Battery Size		
Inserts	<input type="checkbox"/> Std. Short <input type="checkbox"/> Low Short	Others	
Wheels		<input type="checkbox"/> 34430018 Wheel Counterweight Ring	

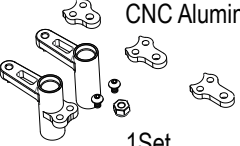
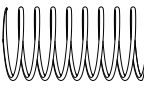
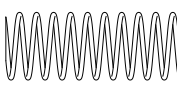
TRACK

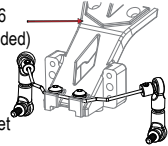
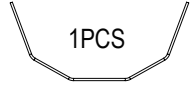
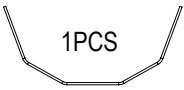
Size	Open <input type="checkbox"/> Medium <input type="checkbox"/> Tight <input type="checkbox"/>
Traction	Very-Low <input type="checkbox"/> Medium <input type="checkbox"/> Very-High <input type="checkbox"/>
Surface	Smooth <input type="checkbox"/> Medium <input type="checkbox"/> Bumpy <input type="checkbox"/>
Type	Clay <input type="checkbox"/> Carpet <input type="checkbox"/> Astro <input type="checkbox"/>
Condition	Blue Groove <input type="checkbox"/> Hard Packed <input type="checkbox"/> Dry <input type="checkbox"/> Dusty <input type="checkbox"/> Loamy <input type="checkbox"/> Wet <input type="checkbox"/>

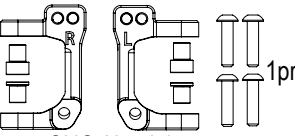
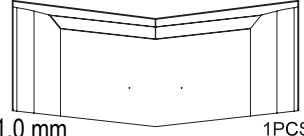
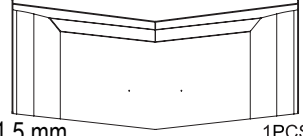
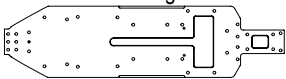
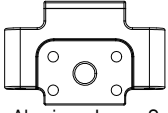
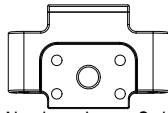
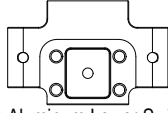
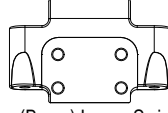

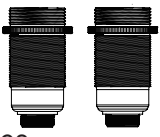
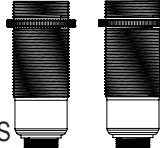
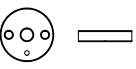
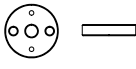
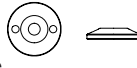
Apply CA Glue if needed

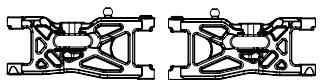
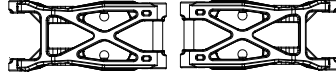
Option Parts

<p>94500063</p>  <p>CNC Aluminium 1PCS</p>	<p>71400702</p>  <p>CNC Aluminium 2PCS</p>	<p>66402686</p>  <p>S1 Ball Diff Outdrive Set +1.3mm</p>	<p>31430016</p> <p>PR P3 Shock O-Rings(Red)</p>  <p>8PCS Hard</p>
<p>81430106</p>  <p>1Set Front Rear Steel Shock Stand off Set</p>	<p>94500037</p>  <p>Carbon Motor Plate heighten 1.5mm</p> <p>1PCS</p>	<p>66481388</p>  <p>50mm Turnbuckles For:Tight Track/Carpet use</p>	<p>17430116</p>  <p>4PCS id 12.8mm x 2.0mm x 2 Hole</p>
<p>66481256</p>  <p>CNC Aluminium 1Set</p>	<p>71530016</p>  <p>10 pr Type R Front Shock Spring Set</p>	<p>71530026</p>  <p>10 pr Type R Front Shock Spring Set</p>	<p>55430086</p>  <p>1PCS 25T For:S1 CNC-(aluminum)</p>
<p>66481556</p>  <p>75400036 (not included)</p> <p>(S1V3FM EVO) PR S1 V3 Front Anti-Roll Bar Drop Link & Collet 1.2mm.1.3mm1.4mm</p>	<p>70220010</p>  <p>1PCS Team PR Racing S1 V4 Back Sway Bar 1.2mm</p>	<p>70220012</p>  <p>1PCS Team PR Racing S1 V4 Back Sway Bar 1.4mm</p>	<p>23440360</p>  <p>(aluminum) 1PCS M5.5mm</p>
<p>91400039</p>  <p>CNC Aluminium 1pr</p>	<p>66400286</p>  <p>1.0 mm 1PCS</p>	<p>66402697</p>  <p>1.5 mm 1PCS</p>	<p>71400705</p> <p>stock usage</p>  <p>PR S1 V4(FM) 3mm carbon fiber chassis 1PCS</p>
<p>66480456</p>  <p>1PCS 21g Caster 3 Degree Aluminum Lower Swing Arm Mount</p>	<p>66481186</p>  <p>1PCS 21.3g Caster 7 Degree Aluminum Lower Swing Arm Mount</p>	<p>66480476</p>  <p>1PCS 19.7g Caster 0 Degree Aluminum Lower Swing Arm Mount</p>	<p>66480536</p>  <p>1PCS 66g Caster 7 Degree (Brass) Lower Swing Arm Mount</p>
<p>68440093</p>  <p>PR RACING 12mm (-1.2mm) 2PCS Clamping Wheel Hex</p>	<p>68440094</p>  <p>PR RACING 12mm (-0.6mm) 2PCS Clamping Wheel Hex</p>	<p>93430016</p>  <p>TYPE R Front Shock Body id 12mm 2PCS</p>	<p>93430026</p>  <p>TYPE R Rear Shock Body id 12mm 2PCS</p>
<p>17430126</p>  <p>4PCS Machined Shock Pistons id 12mm (1.6mm x2 Hole)</p>	<p>17430136</p>  <p>4PCS Machined Shock Pistons id 12mm (1.7mm x2 Hole)</p>	<p>17430146</p>  <p>4PCS Machined Shock Pistons id 12mm Conical (1.6mm x2 Hole)</p>	<p>94500038</p>  <p>1PCS PRS1V4 Aluminum Motor Plate</p>
<p>69400157</p>  <p>PR S1 V4 Front Lower gull Wishbone Graphite (Hard) (1pr)</p>	<p>69400186</p>  <p>PR S1 V4 Rear Lower gull Wishbone Graphite (Hard) (1pr)</p>		





PR S1 (Gear Diff) Gear Ratio Chart-Internal Gear Ratio 2.75:1

(Gear Diff) Final Drive Ratio		Spur 				
		73	75	77	81	83
Pinion 	18					
	19					
	20			10.59		
	21			10.08		
	22		9.38	9.63		
	23		8.97	9.21		
	24	8.36	8.59	8.82		
	25	8.03	8.25	8.47		
	26	7.72	7.93	8.14		
	27	7.44	7.64	7.84		
	28	7.17	7.37			
	29	6.92	7.11			
	30	6.69				
	31	6.48				
32						
33						



PR S1 (Ball Diff) Gear Ratio Chart-Internal Gear Ratio 2.6:1

(Gear Diff) Final Drive Ratio		Spur 				
		73	75	77	81	83
Pinion 	18					
	19			10.54		
	20			10.01		
	21			9.53		
	22		8.86	9.10		
	23		8.48	8.70		
	24	7.91	8.13	8.34		
	25	7.59	7.80	8.01		
	26	7.30	7.50	7.70		
	27	7.03	7.22	7.41		
	28	6.78	6.96			
	29	6.54	6.72			
	30	6.33				
	31	6.12				
32						
33						

66480986	PR Racing 48P Pinion (3.17mm ID) (18T)*1pcs	66481576	PR Racing 48P Pinion (3.17mm ID) (26T)*1pcs
66480996	PR Racing 48P Pinion (3.17mm ID) (19T)*1pcs	66481586	PR Racing 48P Pinion (3.17mm ID) (27T)*1pcs
66481006	PR Racing 48P Pinion (3.17mm ID) (20T)*1pcs	66481596	PR Racing 48P Pinion (3.17mm ID) (28T)*1pcs
66400556	PR Racing 48P Pinion (3.17mm ID) (21T)*1pcs	66481606	PR Racing 48P Pinion (3.17mm ID) (29T)*1pcs
66480096	PR Racing 48P Pinion (3.17mm ID) (22T)*1pcs	66481616	PR Racing 48P Pinion (3.17mm ID) (30T)*1pcs
66480106	PR Racing 48P Pinion (3.17mm ID) (23T)*1pcs	66481626	PR Racing 48P Pinion (3.17mm ID) (31T)*1pcs
66480116	PR Racing 48P Pinion (3.17mm ID) (24T)*1pcs	66481636	PR Racing 48P Pinion (3.17mm ID) (32T)*1pcs
66481566	PR Racing 48P Pinion (3.17mm ID) (25T)*1pcs	66481646	PR Racing 48P Pinion (3.17mm ID) (33T)*1pcs

66480576	73T Spur Gear (For S1)*1pcs
66480586	75T Spur Gear (For S1)*1pcs
66480596	77T Spur Gear (For S1)*1pcs

In case of any errors in the manual, the most current information published by manufacturer shall prevail.

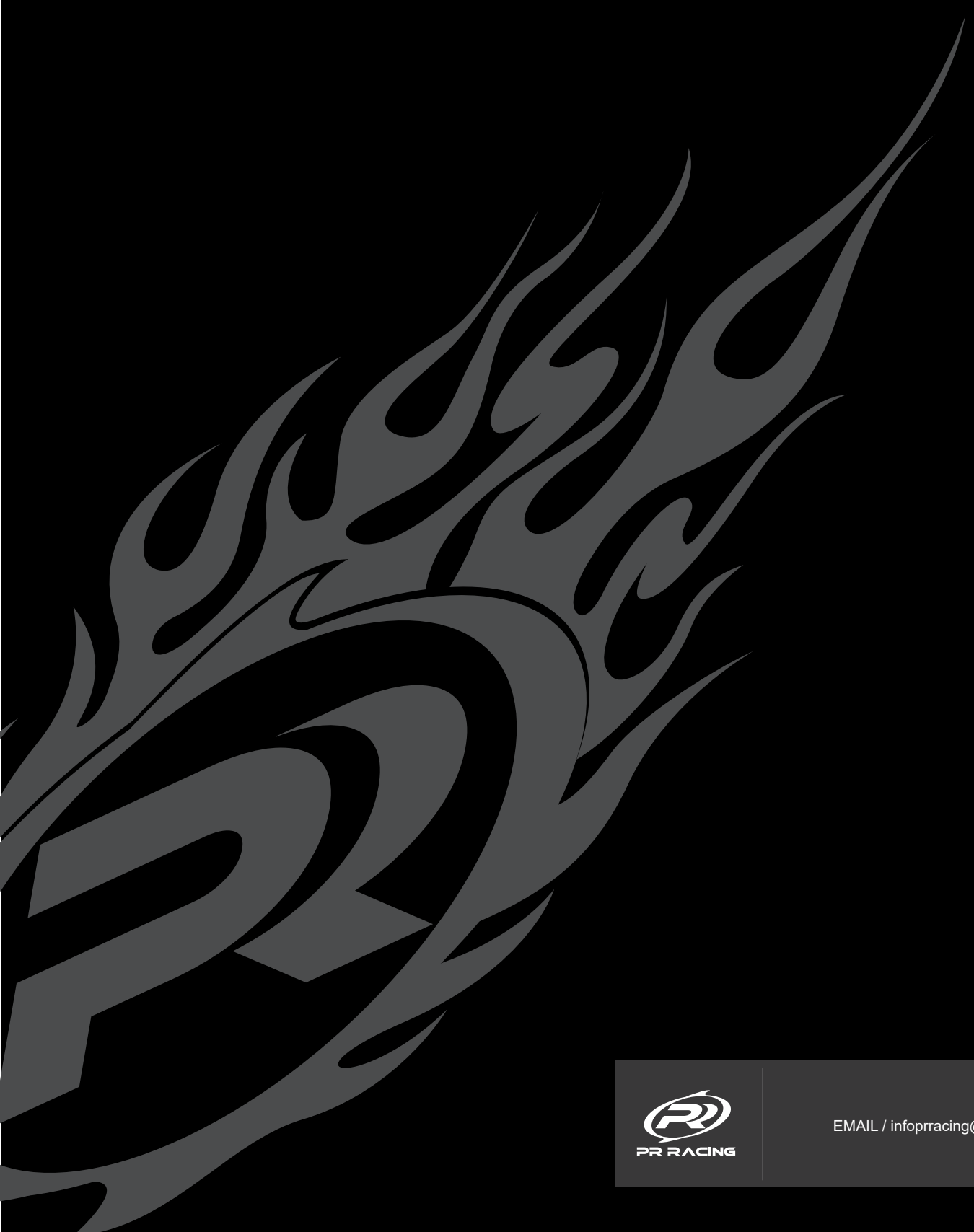

EMAIL / infopracing@gmail.com.tw

1.5 Version