

# PR SB401R-T

ITEM NO:77500406

PR SB401R-T SPORT 1/10 ELECTRIC 4WD OFF-ROAD STADIUM TRUCK / TRUGGY

## SPORT



PR RACING

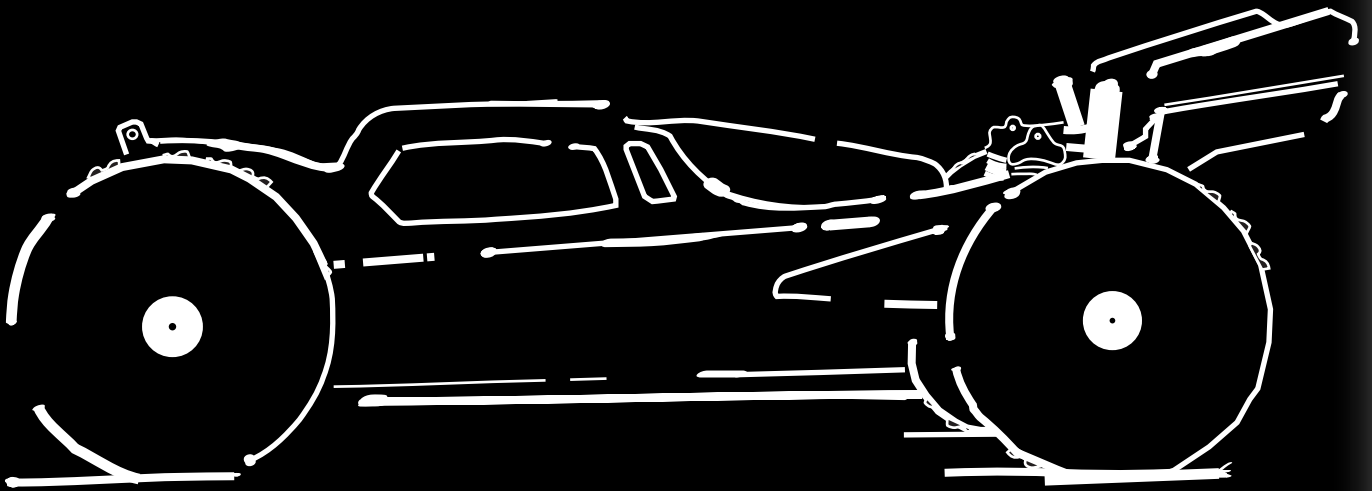

**mit**  
MADE IN TAIWAN

[www.pr-rc.com](http://www.pr-rc.com)

## SAFETY WARNING

This model is a high - performance radio controlled racing product that is designed for use on R/C car race tracks. If it is misused it could cause injury to the operator or others. Many of the items in this kit are small enough to be accidentally swallowed; therefore, it is not suitable for young children. All items, inclusive of liquids, contained in this kit are not intended for human consumption. Rotating parts of the car may cause injury if not handled with care.

Name:PR SB401R-T SPORT 1/10 ELECTRIC 4WD OFF-ROAD STADIUM TRUCK / TRUGGY

Pr racing has taken all the refinements and changes from the 401R buggy, and applied them to create the 401R-T! On top of that we have made further changes specifically for this vehicle to be the most capable, adjustable, durable competition ST 4x4/ Truggy on the market out of the box! From the aggressive "Low Center of gravity" truggy body, to the "Type R" style shocks and towers. The 401R-T is ready to dominate on the very first lap!

## Special features

### CHASSIS:

Hard anodized 2.5mm 6061-T6 Narrow chassis with side pods deck of added durability.

Alloy/carbon floating servo mount

Type R low center of gravity Truggy style body

## TRANSMISSION

Top loading Center gear differential with ultra hard cups

Updated gear ratio

Longer front and rear gear diff out drives for more droop

## SUSPENSION AND STEERING

12.75mm "LCG" Type R Shocks

Type R "Low mount" Carbon fiber towers

Insert style suspension blocks

5 Degree caster blocks

Composite rear hubs with extra pin location for added width adjustability

Gullwing rear arms

High tensile steel turnbuckles

Web link



## SPECIFICATIONS

Type: 1/10th 4wd off-road stadium truck/ truggy

Power: Electric

Wheelbase: Adjustable 284mm to 290mm

Width: Front 325mm Rear 325mm

Gear Ratio: 3:9:1

Weight: 1895grams "Race ready" varies

Hardware: Full metric

Bearings: Sealed metal ball bearings

Wheels: 12mm Hex

Kit: Assembly required

## ITEM REQUIRED TO COMPLETE

2 Channel surface frequency radio system

2S LiPo battery & compatible LiPo charger

1/10th ESC, 540 brushless motor, pinion gear

High speed servo

1/10th Tires and inserts Wheel

Tools, paint for polycarbonate body, tire glue, and threadlock

Silicon diff and shock oil

Instruction manual



- **BEFORE INSTALLATION** ----- 01
- **BAG A** ----- 03-07      ● **BAG E** ----- 18 -20
  - A1-Main Chassis Assembly- Chassis Brace Installation
  - A2-Gear Diff Assembly
  - A3-Center Diff
  - A4-Gear Box Assembly
  - A5 Rear Central Transmission
  - E1-Front & Rear Shock Assembly-R
  - E2-Front & Rear Shock Installation
  - E3-Motor Installation
  - E4-Mounting Tires, Wheel Installation
- **BAG B** ----- 08-11
  - B1-Suspension Mount Installation
  - B2-Front Hub Carrier Assembly(Left Side)
  - B3-Suspension Mount Installation-Sway Bar Installation
  - B4-Front Upper Turnbuckle Assembly
- **BAG C** ----- 12-14
  - C1 RF Suspension Mount
  - C2-Rear Left Hub Carrier Assmebly
  - C3-Rear Upper Rod -Turnbuckle Assembly
  - C4-Sway Bar Installation
- **BAG D** ----- 15 -17
  - D1-Bell Crank Installation
  - D2- Steering
  - D3-Turnbuckle Assembly-Steering Rod -Servo Rod
  - D4-Servo Installation
  - D5-Center Mount Plate
  - D6-Battery Plate Installation
- **SETUP SHEET** -----21
- **Upgrade Parts** ----- 22

## BEFORE INSTALLATION

- 1 Read through the instruction manual before installation in order to have an overview of what to do.
- 2 Check if there is any missing bags or defective parts, if there is, please contact our local dealer or our PR Distributor
- 3 Symbols used throughout the instruction manual, comprises of:



Part bags used.



Assemble as many times as specified (here: twice).



Tighten securely.



Note the direction.



True-to-scale diagram.



Do not over tighten.



Must be purchased separately.



Apply threadlocker (screw cement)



Ensure smooth non-binding movement while assembling.



Assemble in the specified order.



Apply grease.



Cut off shaded portion.



Assemble left and right sides the same way.



Apply oil.

- 4 This kit contains screws and hardware in different metric sizes and shapes. Before using them, check the screws on the true-to-scale diagrams on the left side in each assembly step. Some screw are extras.

## TOOLS REQUIRED

**CAUTION: Handle tools carefully!**

- Needle Nose Pliers

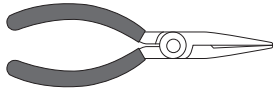

- Awl

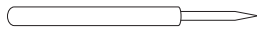

- Sharp Hobby Knife

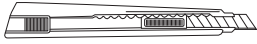

- Hex Wrench



1.5mm

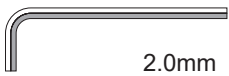

2.0mm

- SILICON DIFF OIL

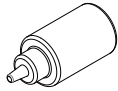

- Grease



- Wire Cutters



- SP Knife Edge Reamer

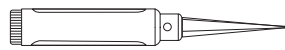

- Do not pre-drill as precise drilling of 1mm to 15mm holes can be performed after body shell painted.

- Screw Cement



- Ball Differential Grease



- Round Cutter & Sander

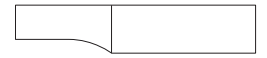
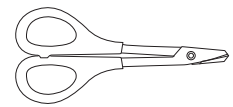

- For trimming bodies Cutting along curved lines was never so easy!

Cross Wrench

- 5.0mm-5.5mm
- 7.0mm-8.0mm

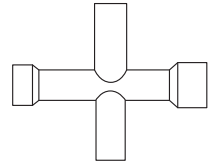

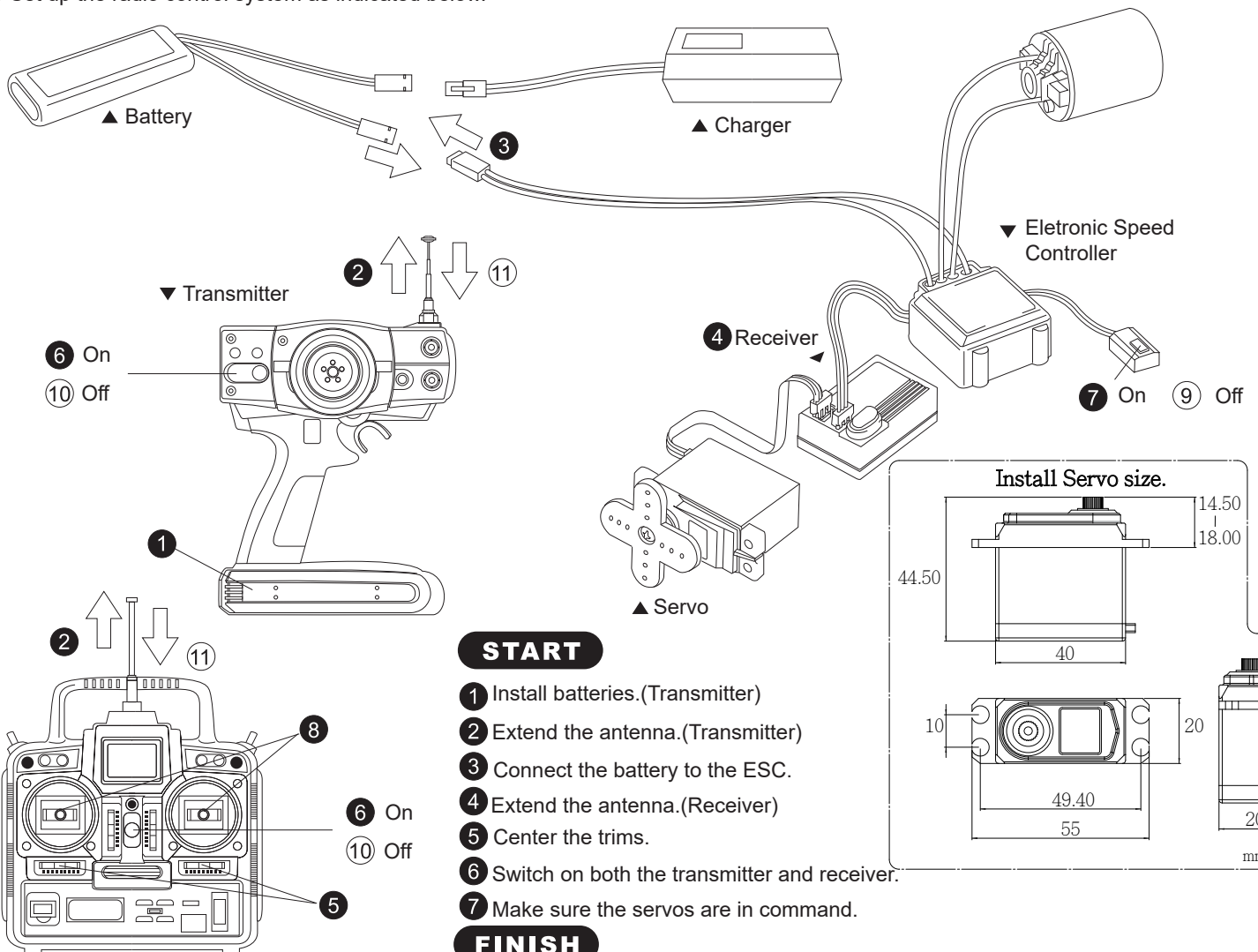

## RADIO PREPARATION

- A new battery must be charged before it is used. Refer to the charger instruction manual for charging.
- Set up the radio control system as indicated below.



**A1** Chassis Brace Installation Main Chassis Assembly

-  16  
M3X8mm  
82400026
-  3  
M3X8mm  
80400036

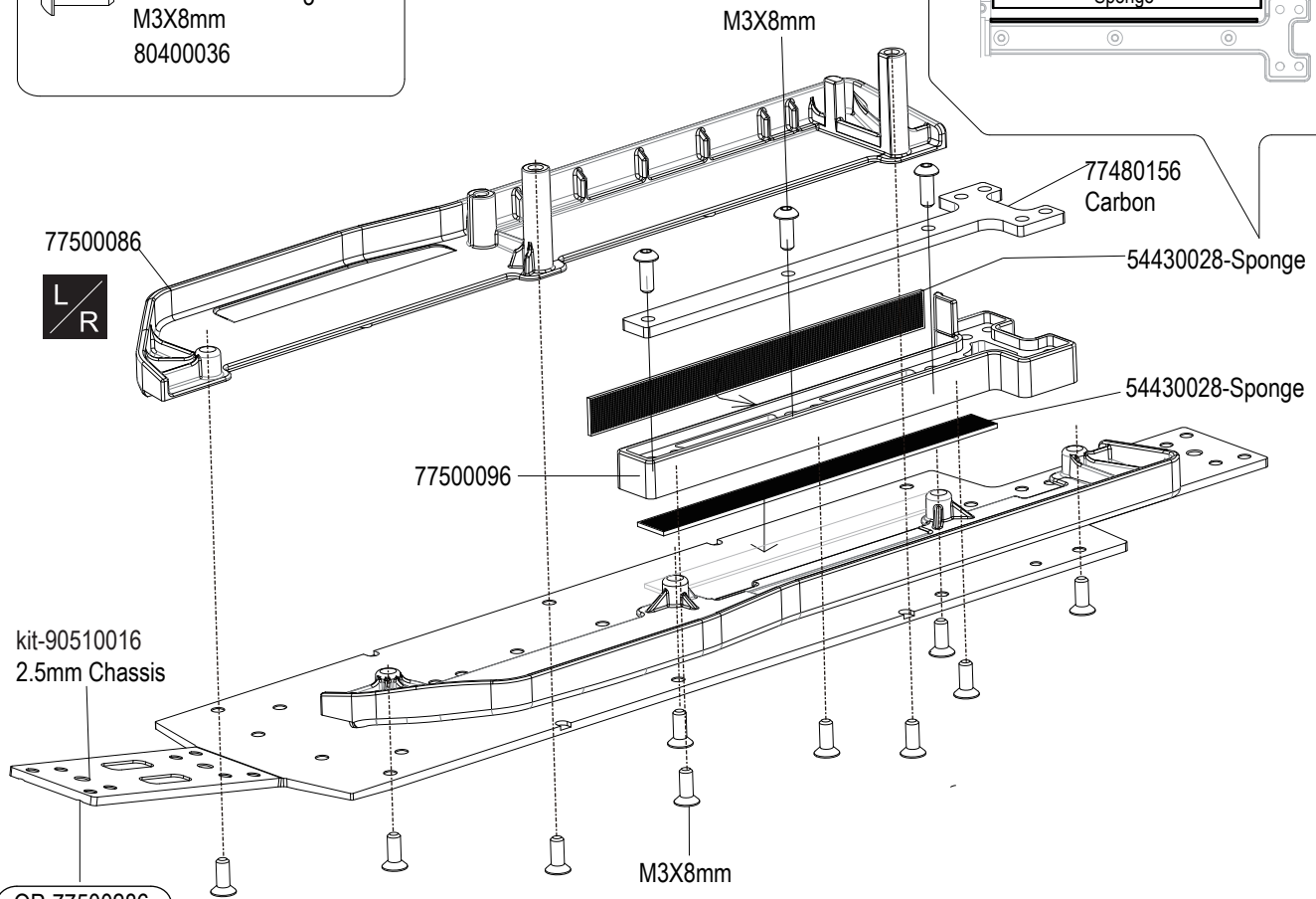
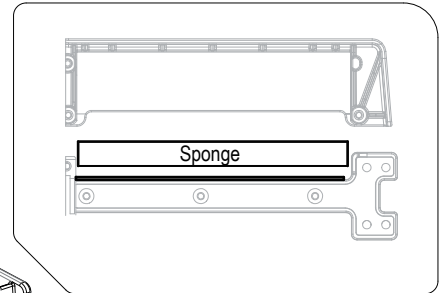

OP-77500286  
2mm Chassis

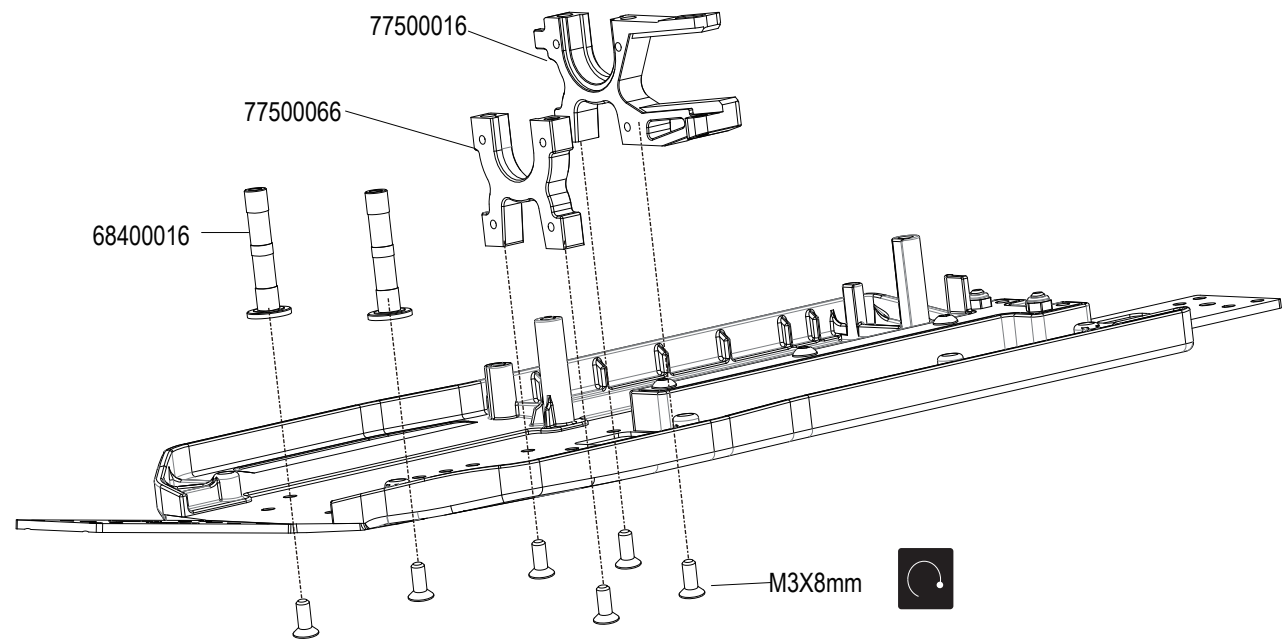



BAG A

# A2 Gear Diff Assembly

- |                                   |                                  |
|-----------------------------------|----------------------------------|
| 8<br>M2.6X10mm<br>82400166        | 4<br>3.5mm<br>85400016           |
| 4<br>5X8x0.8mm Shim<br>85440170   | 4<br>O-ring -5x1.5mm<br>31450016 |
| 8<br>4X10x0.15mm Shim<br>85440160 |                                  |

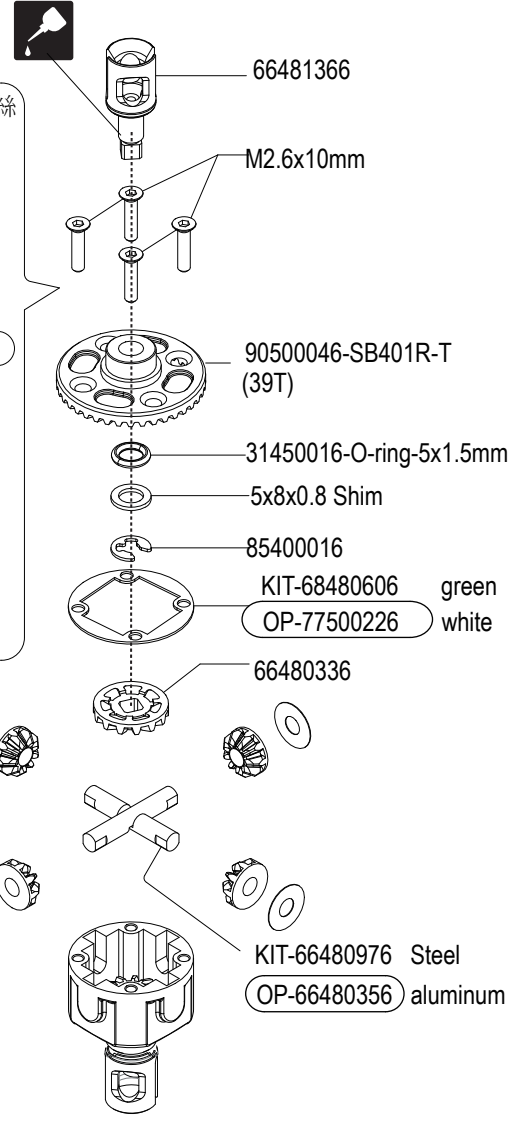
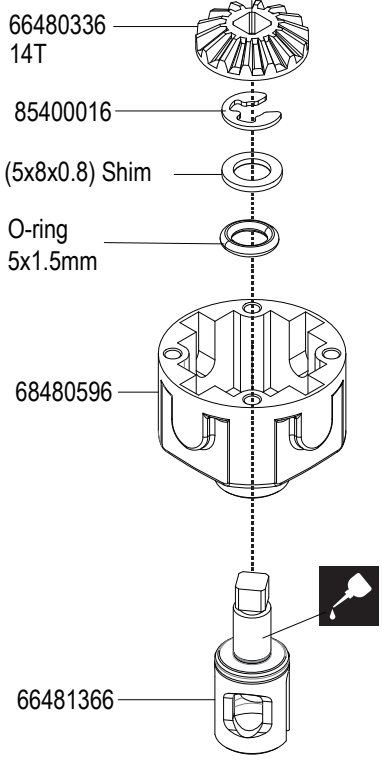
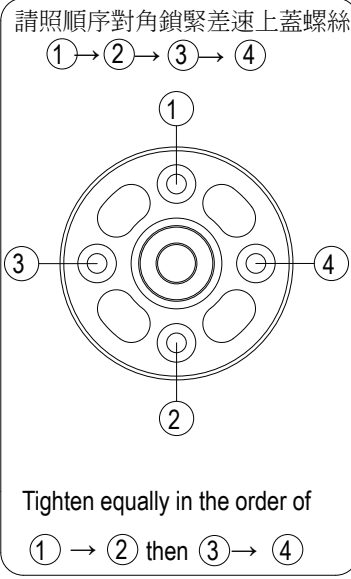

**x2**



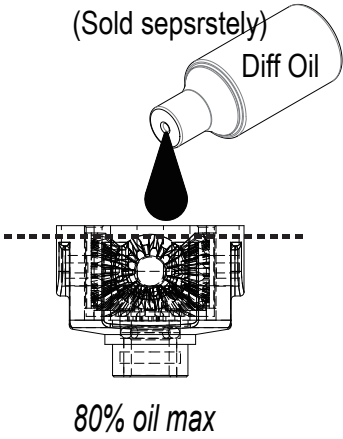

Assemble 1 Front and 1 Rear



After first drive  
adjust  
for track conditions  
**SILICON DIFF OIL**  
10000 Front  
5000 Rear

## A3 Center Diff

BAG  
A

- |  |  |
|--|--|
|  4<br>M2.6X10mm<br>82400166       |  2<br>3.5mm<br>85400016           |
|  2<br>5X8x0.8mm Shim<br>85440170  |  4<br>O-ring -5x1.5mm<br>31450016 |
|  4<br>4X8x0.25mm Shim<br>85440150 |  |

KIT  
77480106  
SB401-R 80T  
Central Differential Set

OP 77480146  
SB401-R 77T  
Central Differential Set

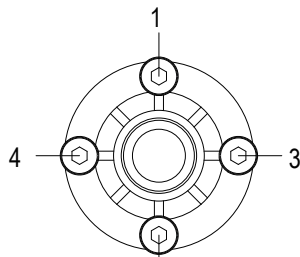

照順序對角輕鎖上差速上蓋螺絲  
1 → 2    3 → 4  
Tighten equally in the order of  
1 → 2 then 3 → 4

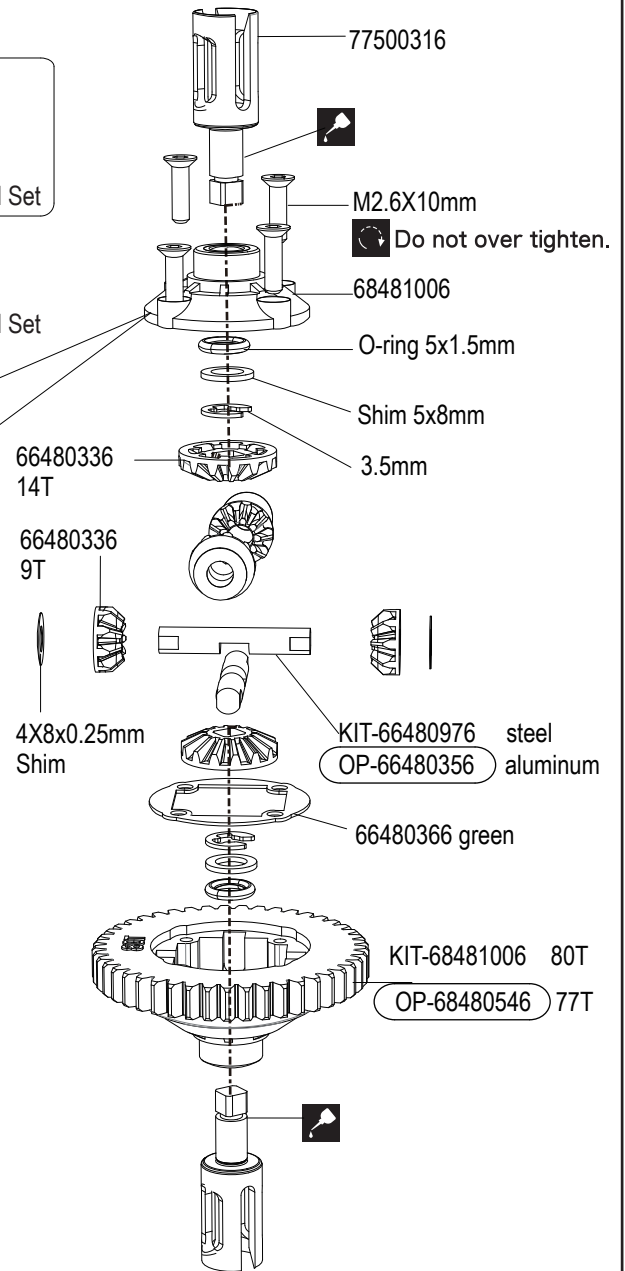
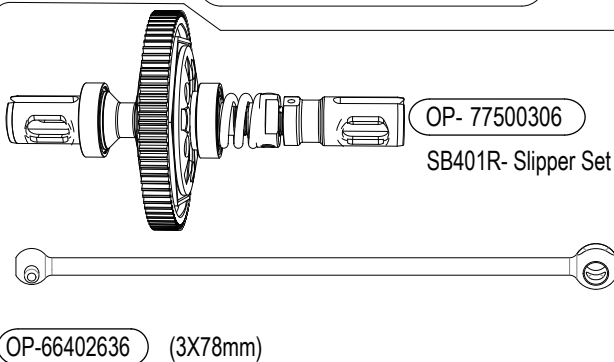

(Sold seprstely)

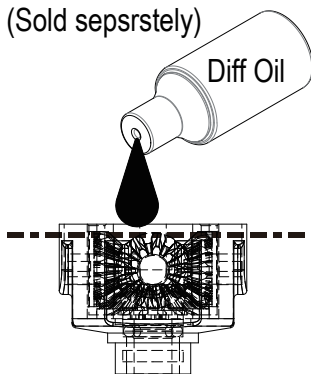

80% oil max

After first drive  
adjust  
for track conditions  
SILICON DIFF OIL

# 30000- # 50000













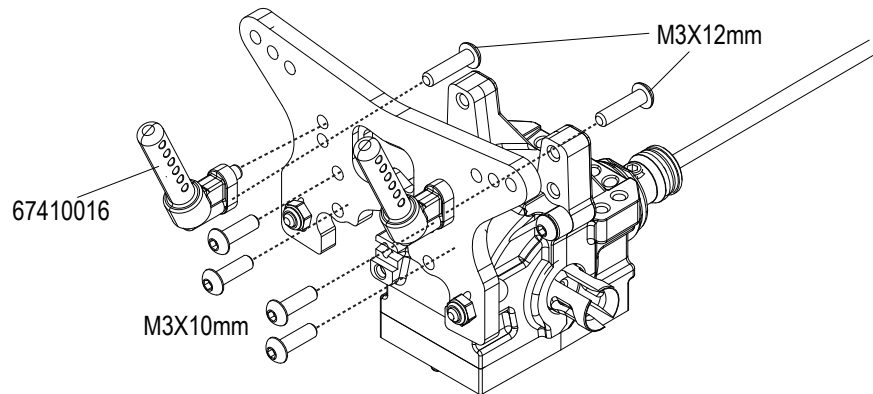
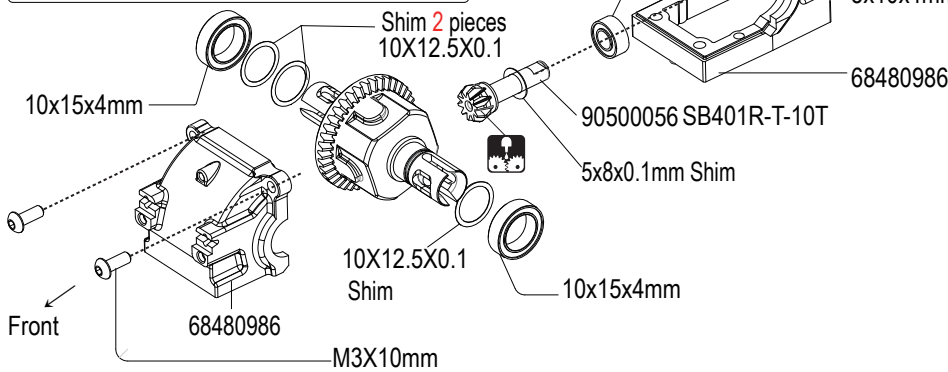
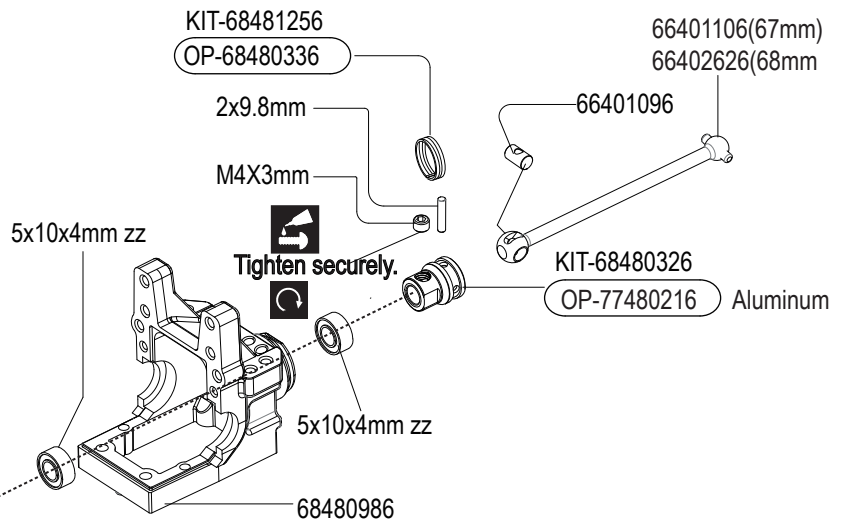
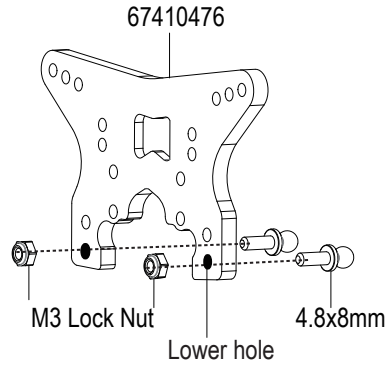

BAG A

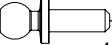
A4 Gear Box Assembly Front Front Shock Tower nstallation

# Front

- 2  
4.8x8mm Ball Studs-68430046
- 2  
M3 Lock Nut 83400026
- 6  
M3X10mm 80400046
- 2  
M3X12mm 80400206
- 1  
5x8x0.1mm Shim 8544000
- 4  
10X12.5X0.1 Shim 85440230
- 2  
5x10x4mm Ball Bearing  
89430010
- 2  
10x15x4mm Ball Bearing  
89430030
- 1  
79400086(2x9.8mm)
- 1  
M4X3mm Set Screw 8400016



-  2  
4.8x8mm Ball Studs  
68430046
-  2  
M3 Lock Nut -83400026
-  7  
M3X10mm 80400046
-  1  
M4X3mm Set Screw  
78400016
-  1  
5x8x0.1mm Shim  
85440090
-  4  
10X12.5X0.1 Shim  
85440230
-  2  
5x10x4mm Ball Bearing  
89430010
-  2  
10x15x4mm Ball Bearing  
89430030
-  1  
(2x9.8mm)-79400086

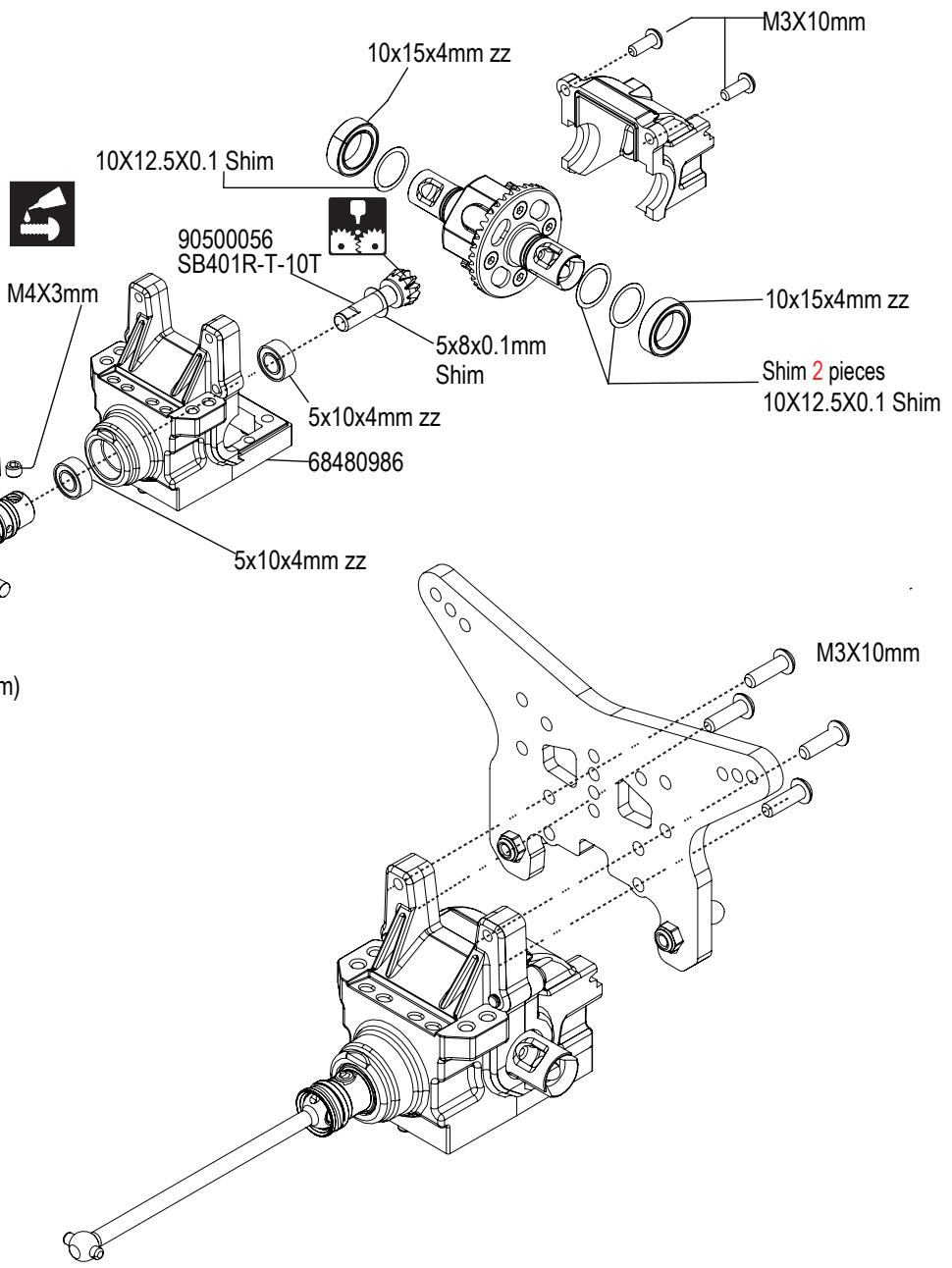
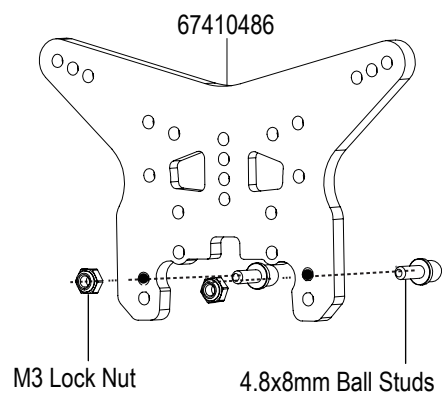

Front



BAG B

# B1 Suspension Mount Installation

## FRONT HANGER INSERTS

- 2  
M3 Lock Nut -83400026
- 2  
M3X8mm 82400026
- 2  
M3X10mm 82400106
- 4  
M3X15mm 82400176

Note position-77500156

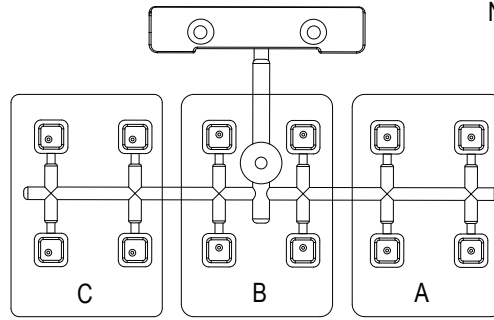

| Numbering | FF | FR | TOE  | SQUAT |
|-----------|----|----|------|-------|
| F-1       |    |    | 0    | 0     |
| F-2       |    |    | 0    | +0.7  |
| F-3       |    |    | 0    | +1.4  |
| F-4       |    |    | 0    | -0.7  |
| F-5       |    |    | 0    | 0     |
| F-6       |    |    | 0    | +0.7  |
| F-7       |    |    | 0    | -1.4  |
| F-8       |    |    | 0    | -0.7  |
| F-9       |    |    | 0    | 0     |
| F-10      |    |    | 0    | 0     |
| F-11      |    |    | -0.9 | 0     |
| F-12      |    |    | -1.7 | 0     |
| F-13      |    |    | +0.9 | 0     |
| F-14      |    |    | 0    | 0     |
| F-15      |    |    | -0.9 | 0     |
| F-16      |    |    | +1.7 | 0     |
| F-17      |    |    | +0.9 | 0     |
| F-18      |    |    | 0    | 0     |
| R-19      |    |    | +3.5 | +2    |

Suspension Mount FR  
KIT-77500116

OP-77510020 -2mm

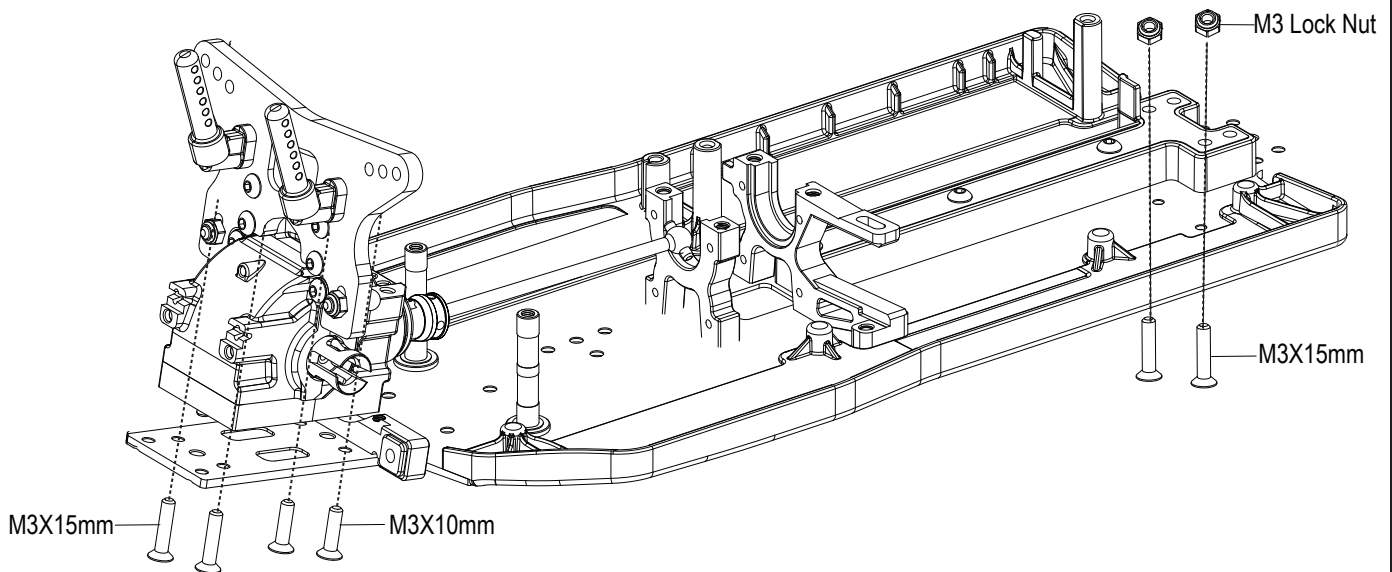
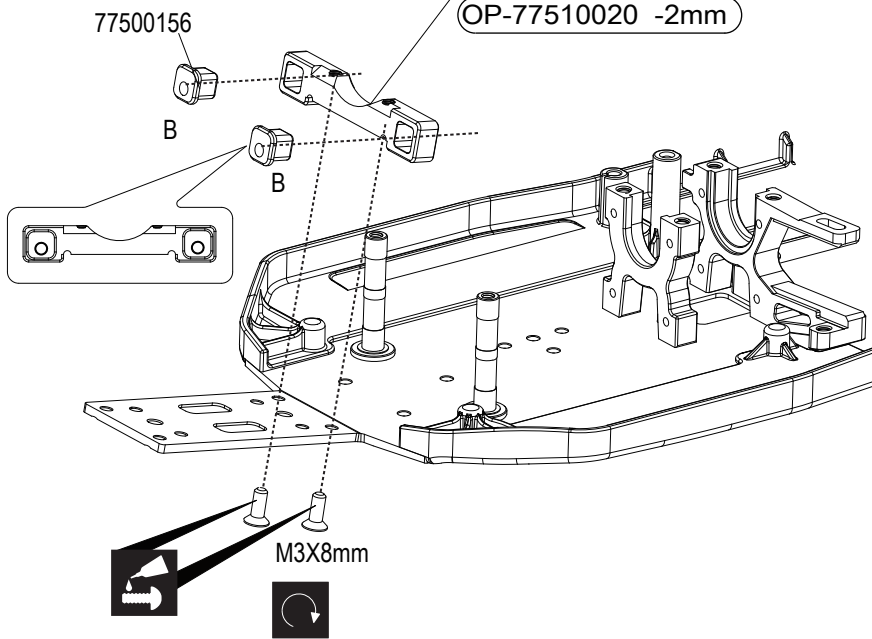

## B2 Front Hub Carrier Assembly (Left Side)

### Left Side



- 2  
M3x12mm 80400206
- 2  
4.8mmx6mm 68430036  
Ball Studs
- 1  
5x10x4mm zz Ball Bearing  
89430010
- 1  
5x13x4mm zz Ball Bearing  
89430020
- 1  
Pin 2x9.8mm 79400086
- 1  
Pin 2 x10.8mm-79400016
- 2  
Shim 5x8x0.1mm-85440090
- 1  
m2X5mm-87400066

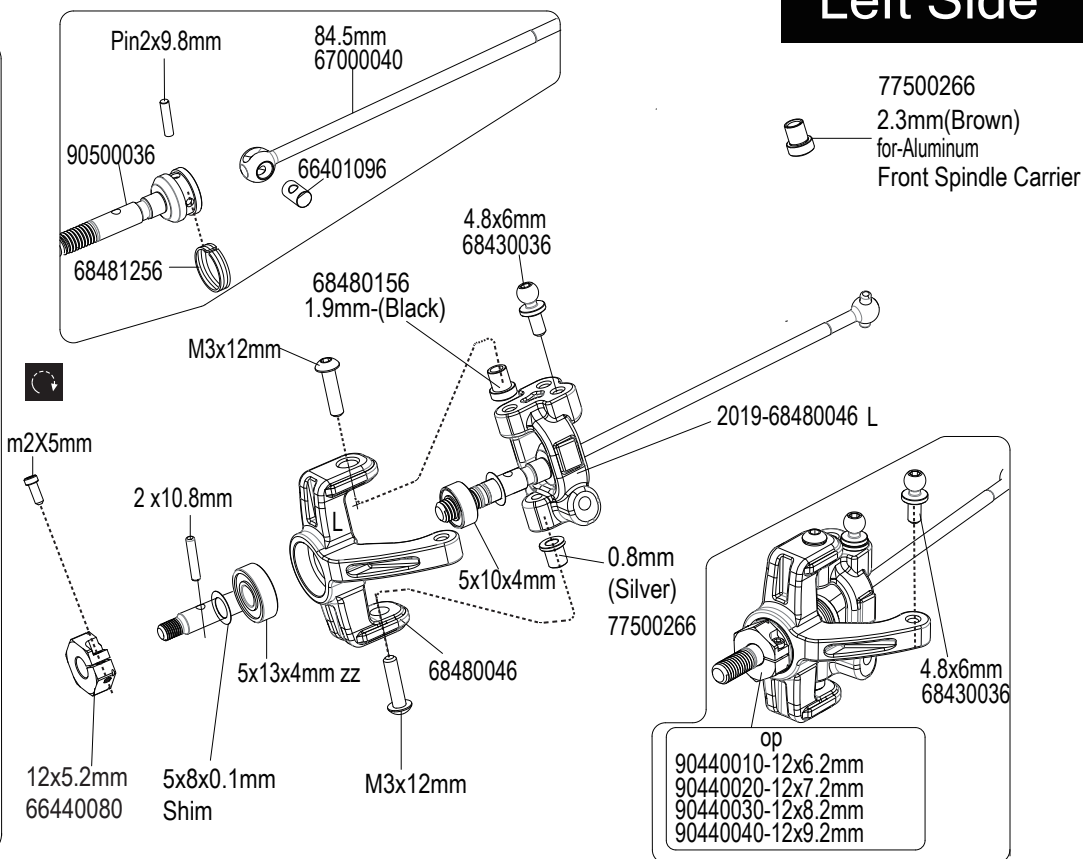

## B2 Front Hub Carrier Assembly (Right Side)

### Right Side



- 2  
M3x12mm 80400206
- 2  
4.8mmx6mm 68430036  
Ball Studs
- 1  
5x10x4mm zz Ball Bearing  
89430010
- 1  
5x13x4mm zz Ball Bearing  
89430020
- 1  
Pin 2x9.8mm 79400086
- 1  
Pin 2 x10.8mm-79400016
- 2  
Shim 5x8x0.1mm-85440090
- 1  
m2X5mm-87400066

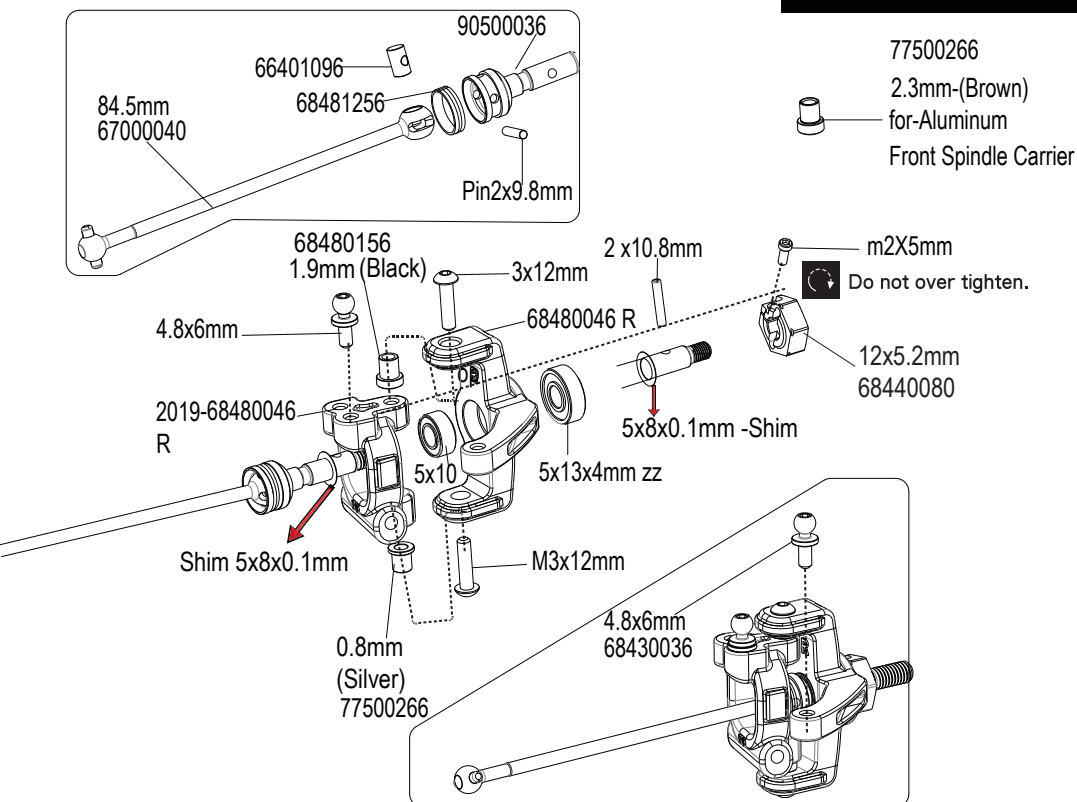



BAG B

# B3 Suspension Mount Installation- Sway Bar Installation

- 2  
M3X6mm 82400016
- 2  
M3X8mm 82400026
- 2  
M2.5X4mm 80400016
- 2  
M3X8mm 80400036
- 2  
M3X3mm 87400016
- 2  
M3X6mm Set Screw 78400026
- 2  
Pin 3x36.8mm-66430110
- 2  
Pin 3x52mm-66430370

- 2  
3 x8 x0.15mm 85440320-Shim

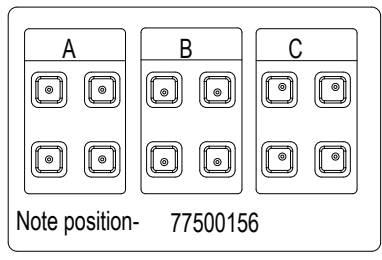
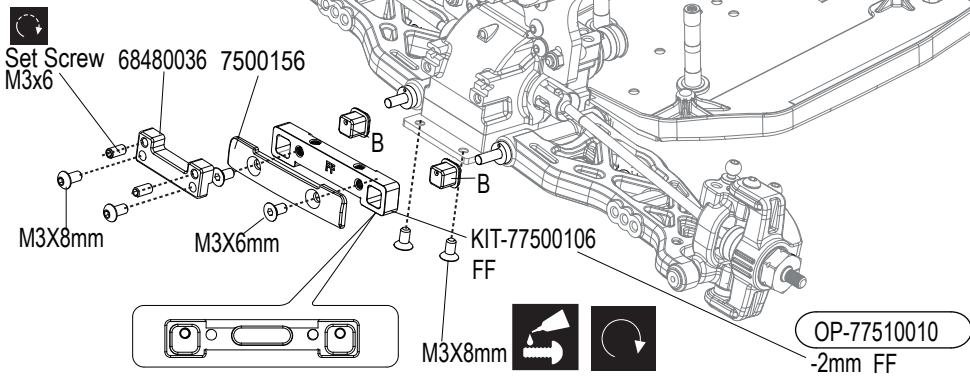
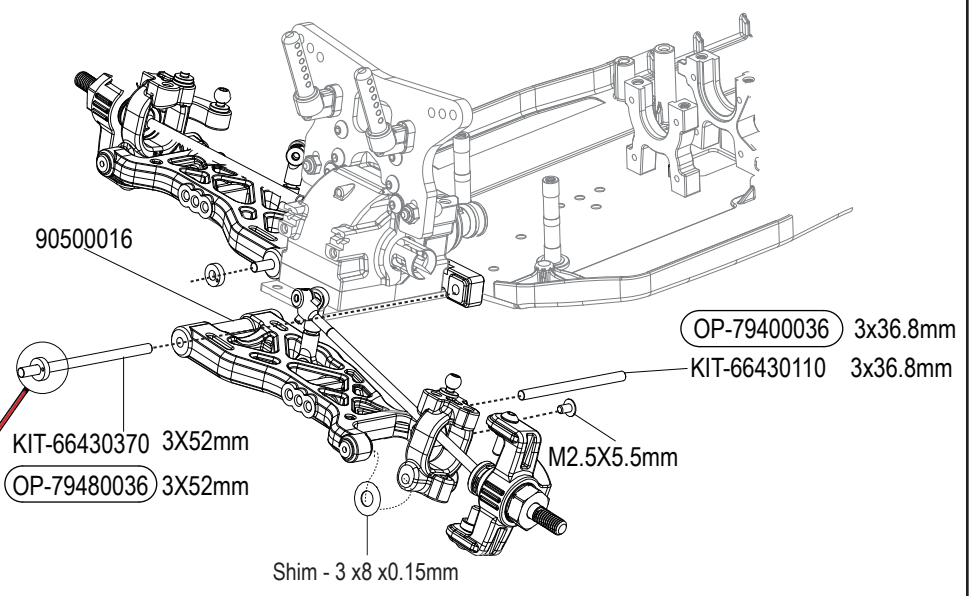
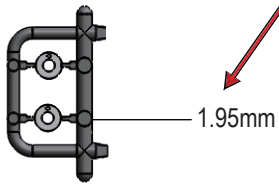



# B4 Front Upper Turnbuckle Assembly

One side is reverse threaded.

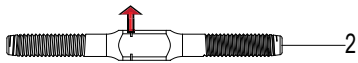

36mm Turnbuckles (Black)  
66400346

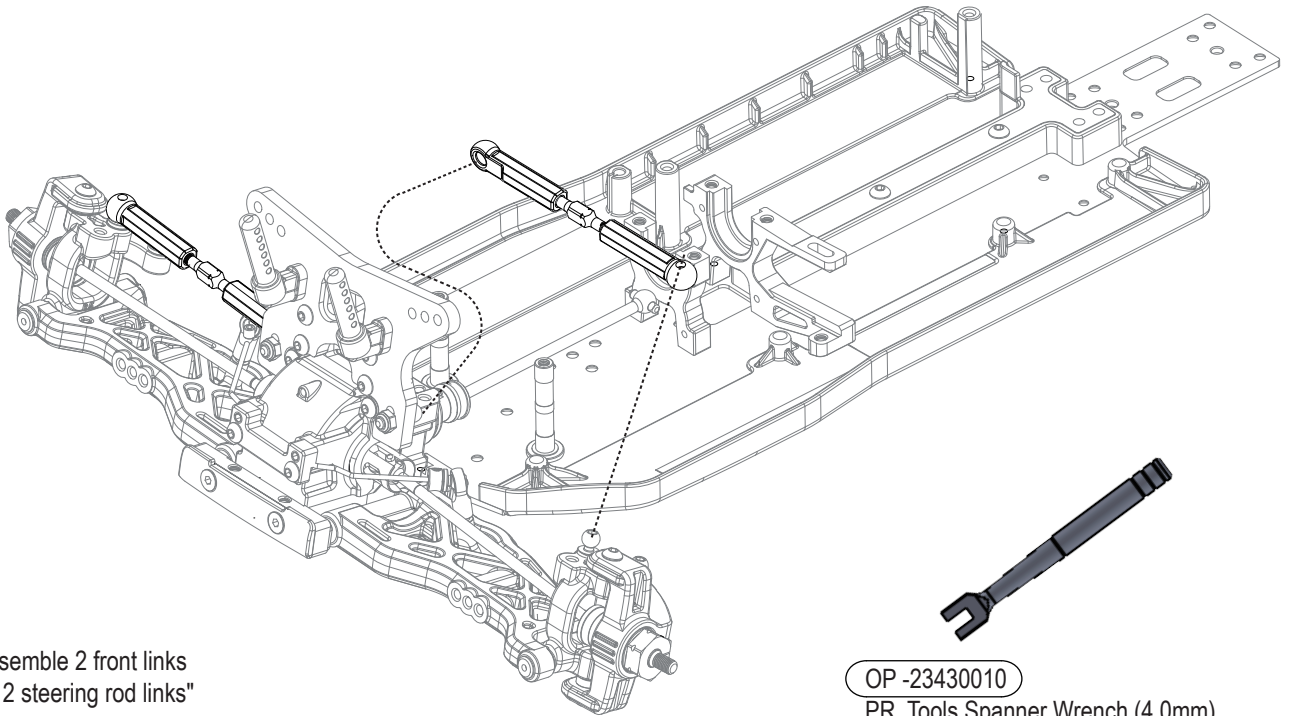

" Assemble 2 front links  
and 2 steering rod links"

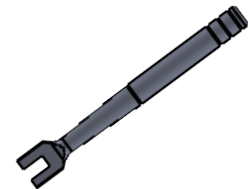

OP -23430010  
PR Tools Spanner Wrench (4.0mm)

**1:1**

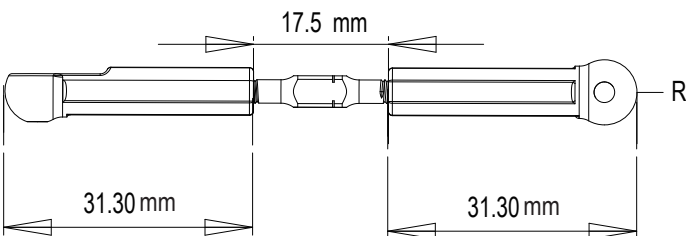
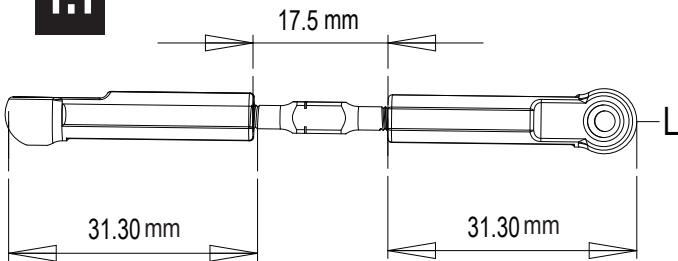

One side is reverse threaded.

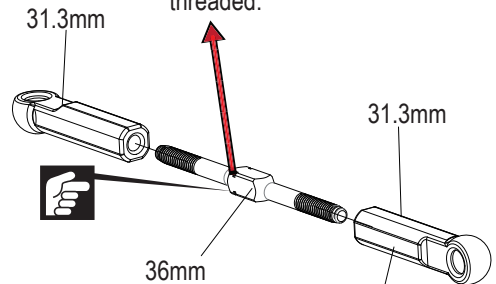

KIT-66400346 (Black)

OP-77430016 (Silver)

31.3mm  
66400066  
black





# C1 RF Suspension Mount

- 5  
M3X10mm 80400046
- 2  
M3X8mm 82400026
- 2  
M3X10mm 82400106
- 2  
M3X15mm 82400176

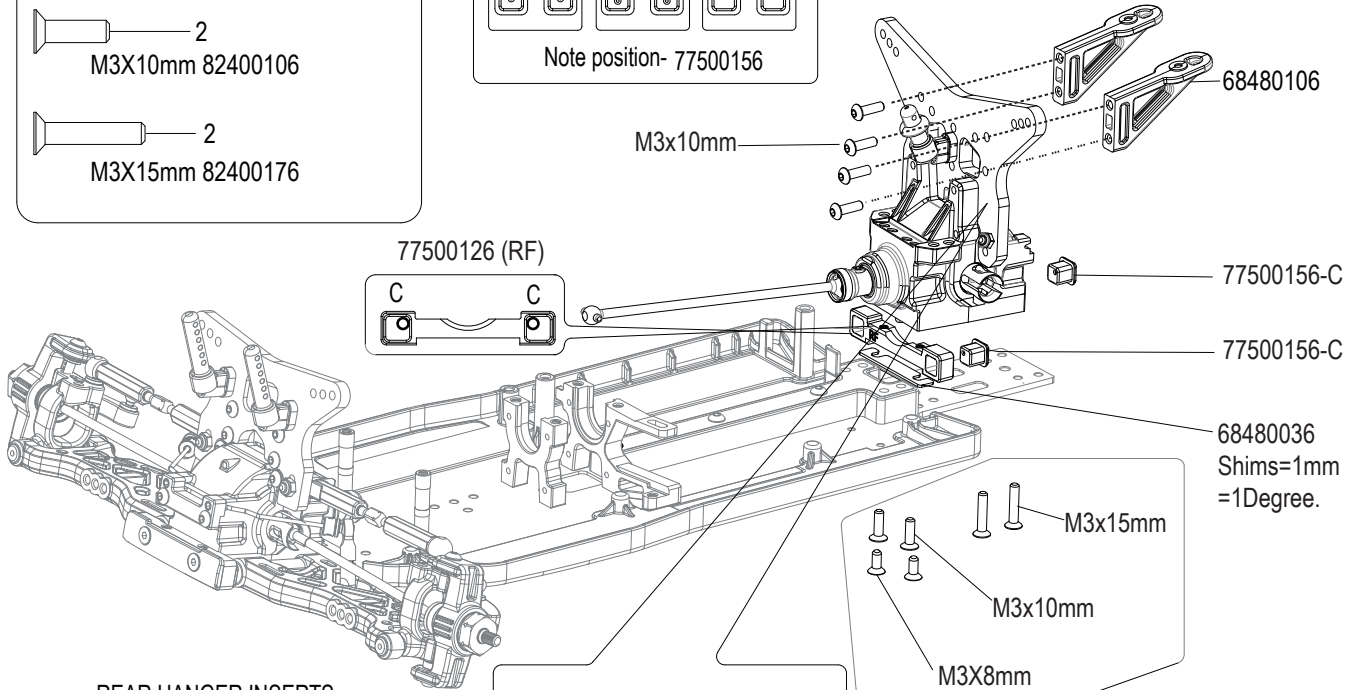
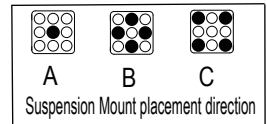
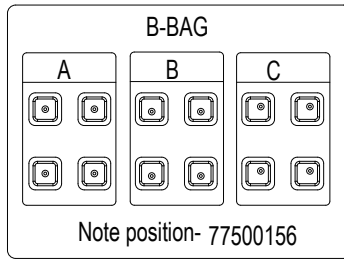

## REAR HANGER INSERTS

| Numbering | RF | RR | TOE  | SQUAT |
|-----------|----|----|------|-------|
| R-1       |    |    | +1.6 | 0     |
| R-2       |    |    | +1.6 | +0.7  |
| R-3       |    |    | +1.6 | +1.4  |
| R-4       |    |    | +1.6 | -0.7  |
| R-5       |    |    | +1.6 | 0     |
| R-6       |    |    | +1.6 | +0.7  |
| R-7       |    |    | +1.6 | -1.4  |
| R-8       |    |    | +1.6 | -0.7  |
| R-9       |    |    | +1.6 | 0     |
| R-10      |    |    | +1.6 | 0     |
| R-11      |    |    | +0.8 | 0     |
| R-12      |    |    | 0    | 0     |
| R-13      |    |    | +2.5 | 0     |
| R-14      |    |    | +1.6 | 0     |
| R-15      |    |    | +0.8 | 0     |
| R-16      |    |    | +3.0 | 0     |
| R-17      |    |    | +2.5 | 0     |
| R-18      |    |    | +1.5 | 0     |
| R-19      |    |    | +3.5 | +2    |

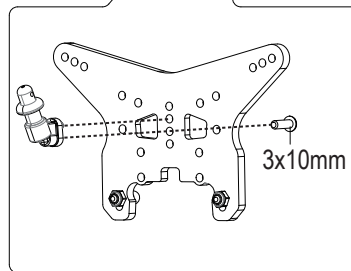

Note: (1) SB401 Plastic Antisquat Shims=1mm=1Degree.

## C2 Rear Left Hub Carrier Assmely



Assemble the right left side in the same manner.

- 2  
M3X8mm 82400026
- 4  
m2.5X4mm 80400016
- 2  
10x15x4mm zz Ball Bearing 89430030
- 2  
5x13x4mm zz Ball Bearing 89430020
- 2  
Shim 5x8x0.1mm 85440090
- 2  
PIN(3x52mm)66430370
- 2  
PIN(3x36.8mm)66430110
- 2  
PIN(2 x 10.8mm)79400016
- 2  
PIN(2 x 9.8mm)79400086
- 2  
m2X5mm-87400066

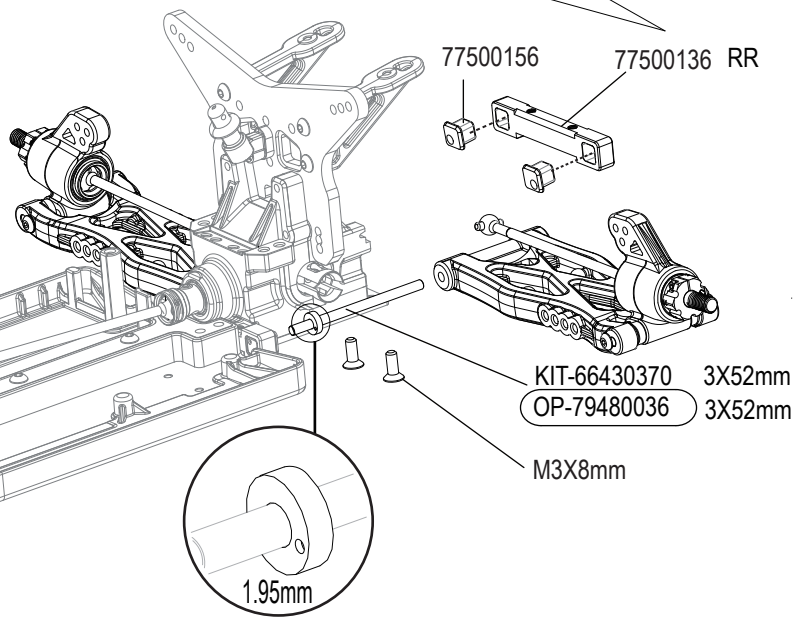
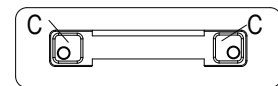
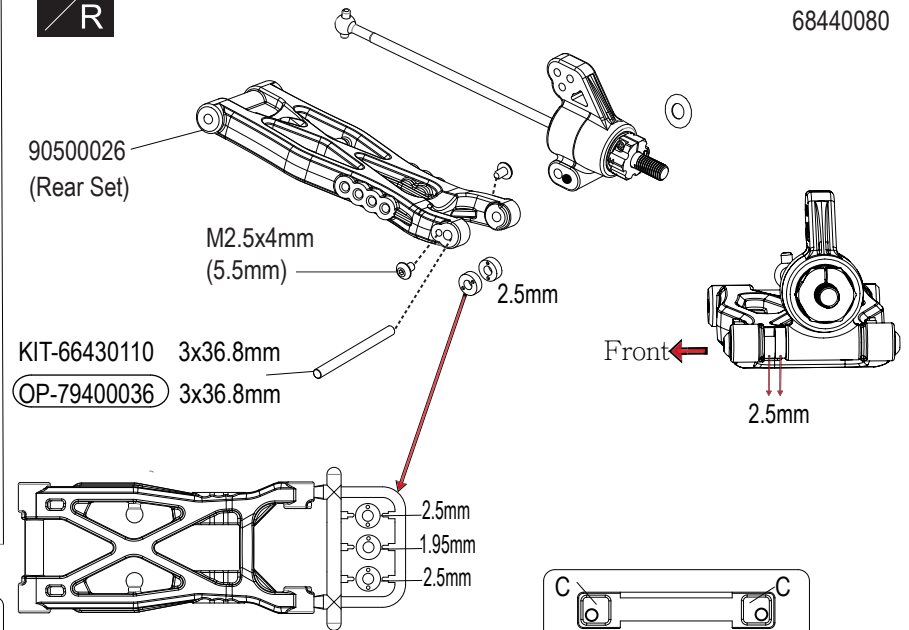
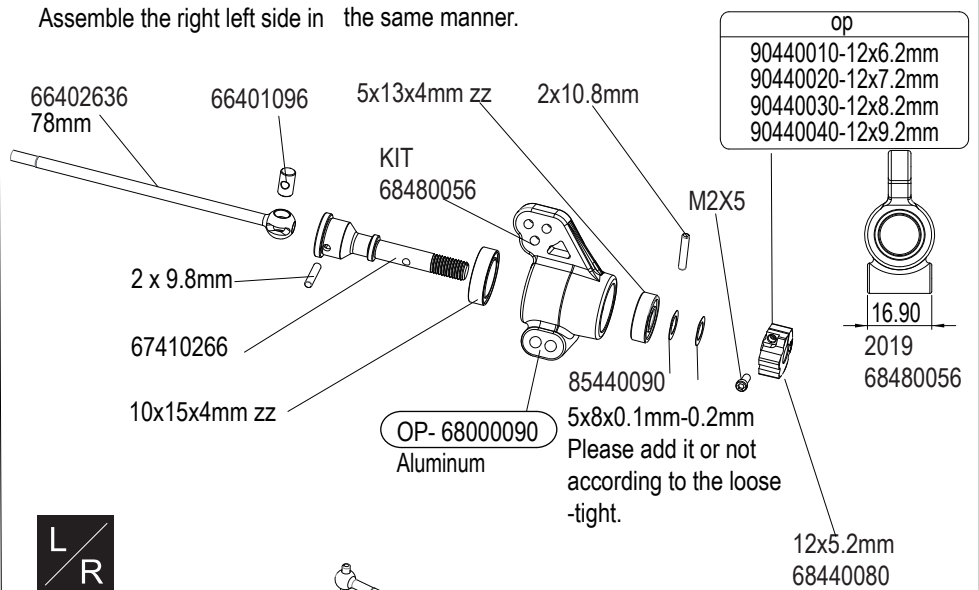
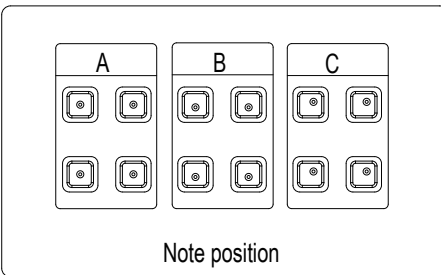







# C3 Rear Upper Rod -Turnbuckle Assembly



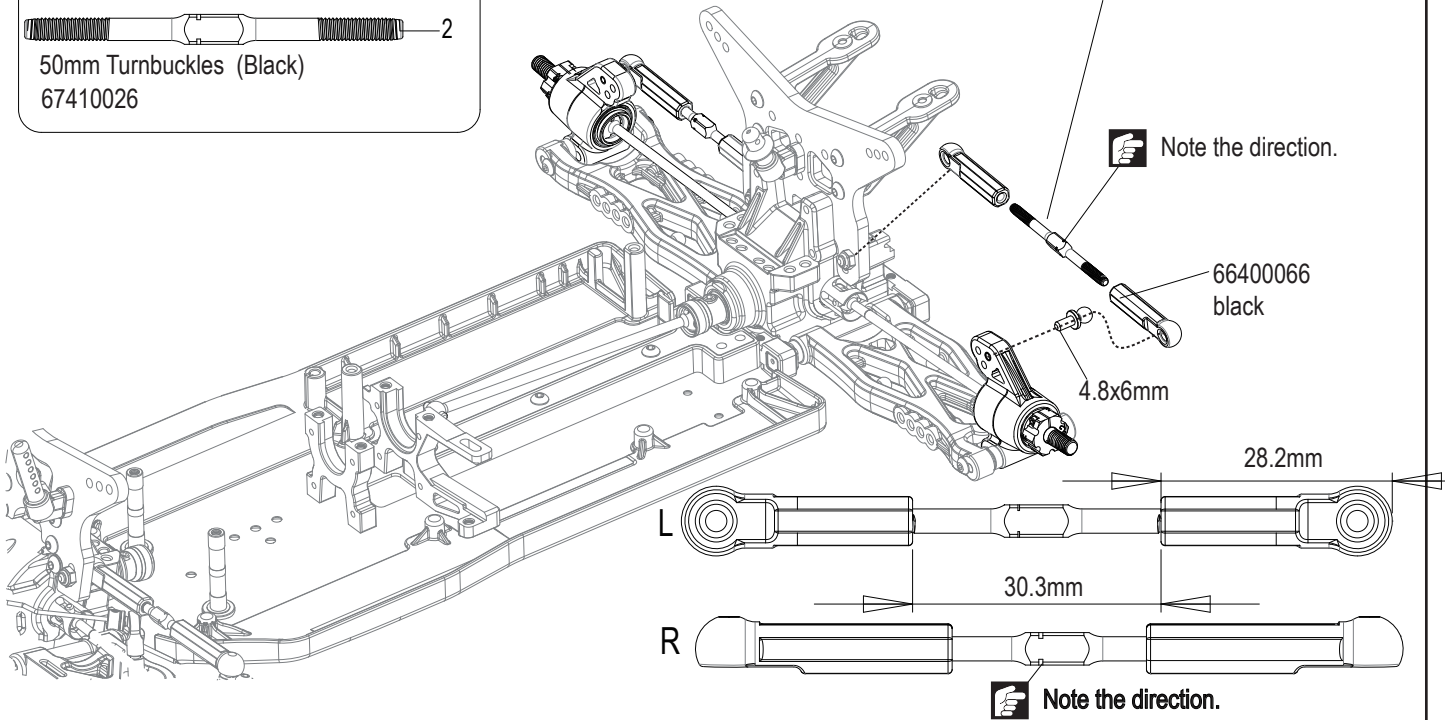

-  2  
4.8x6mm Ball Studs  
68430036
-  2  
50mm Turnbuckles (Black)  
67410026

- KIT-67410026 (50mm) (Black)
- OP-77430056 (50mm) (Silver)



# C4 Sway Bar Installation



-  2  
M3X8mm 80400036
-  2  
M3X3mm 87400016
-  2  
M3X6mm 78400026

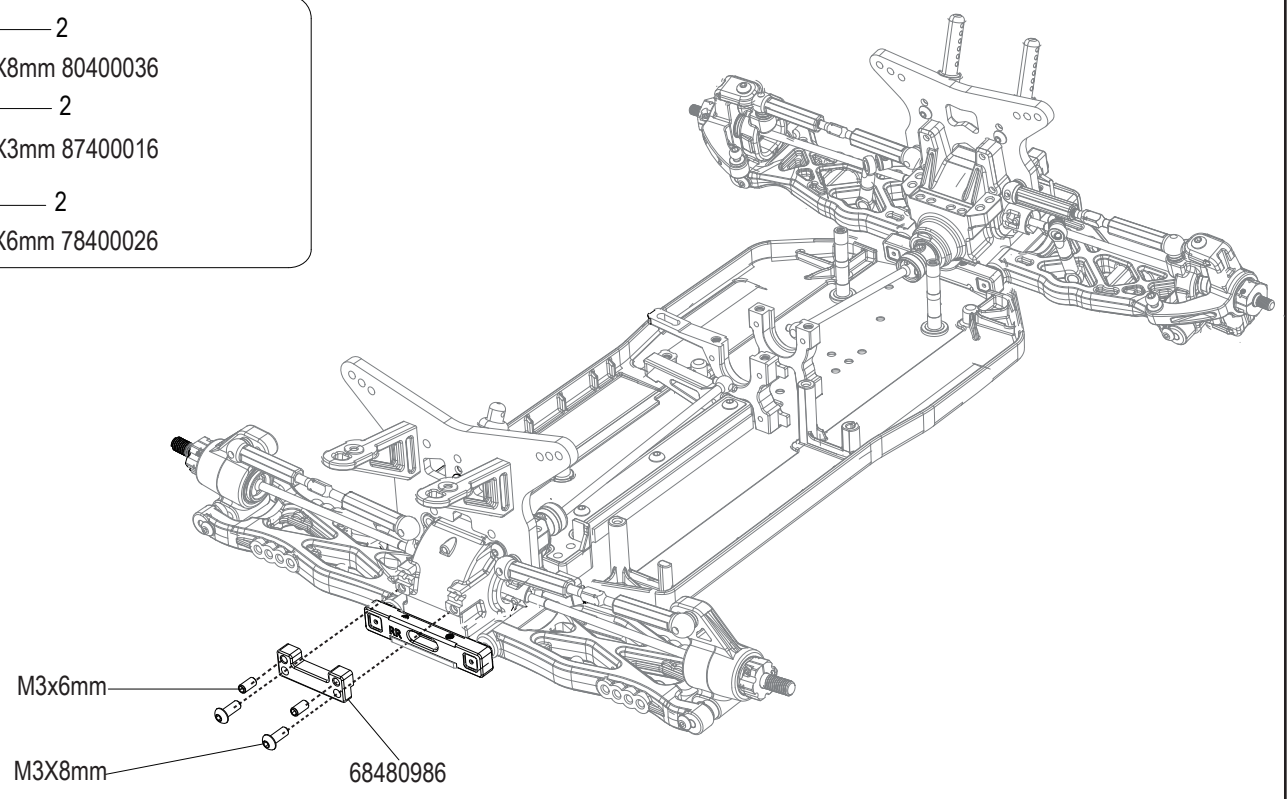



# D1 Bell Crank Installation

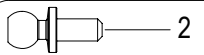

2  
4.8x6mm Ball Studs  
68430036

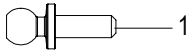

1  
4.8x8mm Ball Studs  
68430046



2  
M3 Lock Nut-83400026



1  
Silver Aluminum Spacer  
3x6.6x1mm-85440310

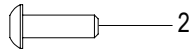

2  
M3x10mm 80400046



2  
00430025  
Steering Knuckle Bushing  
3x6mm

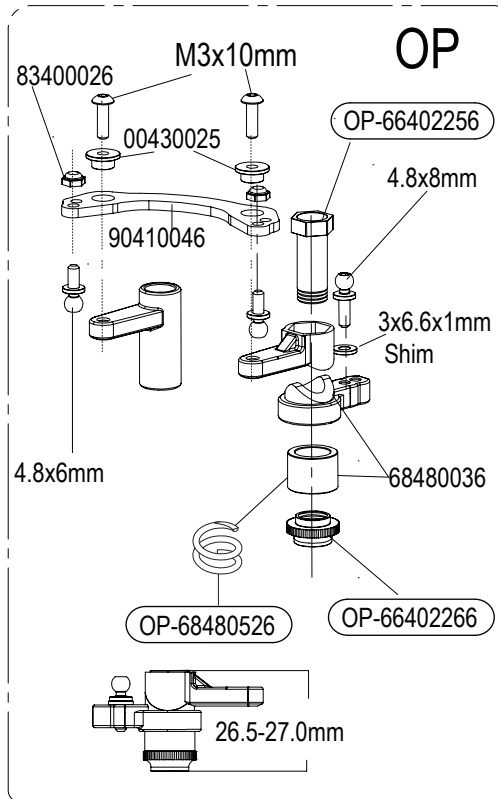

## KIT

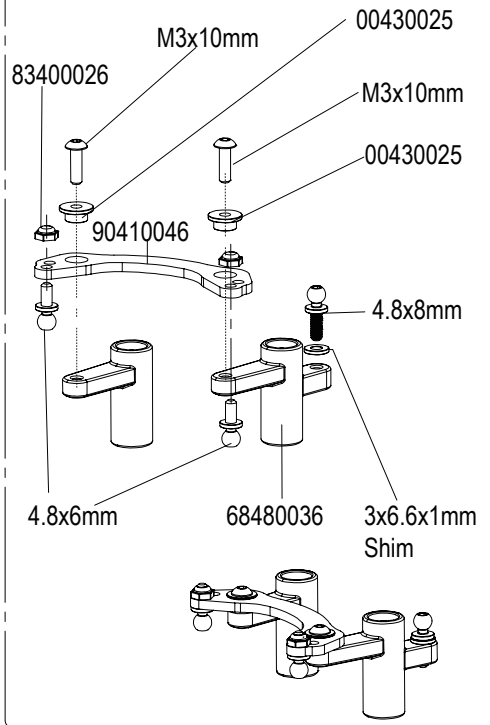

# D2 Steering



2  
M3X6mm 80400026



4  
5x8x2.5mm Plastic Bearing  
66402106



4  
Shim 5x8x0.2mm  
85440010

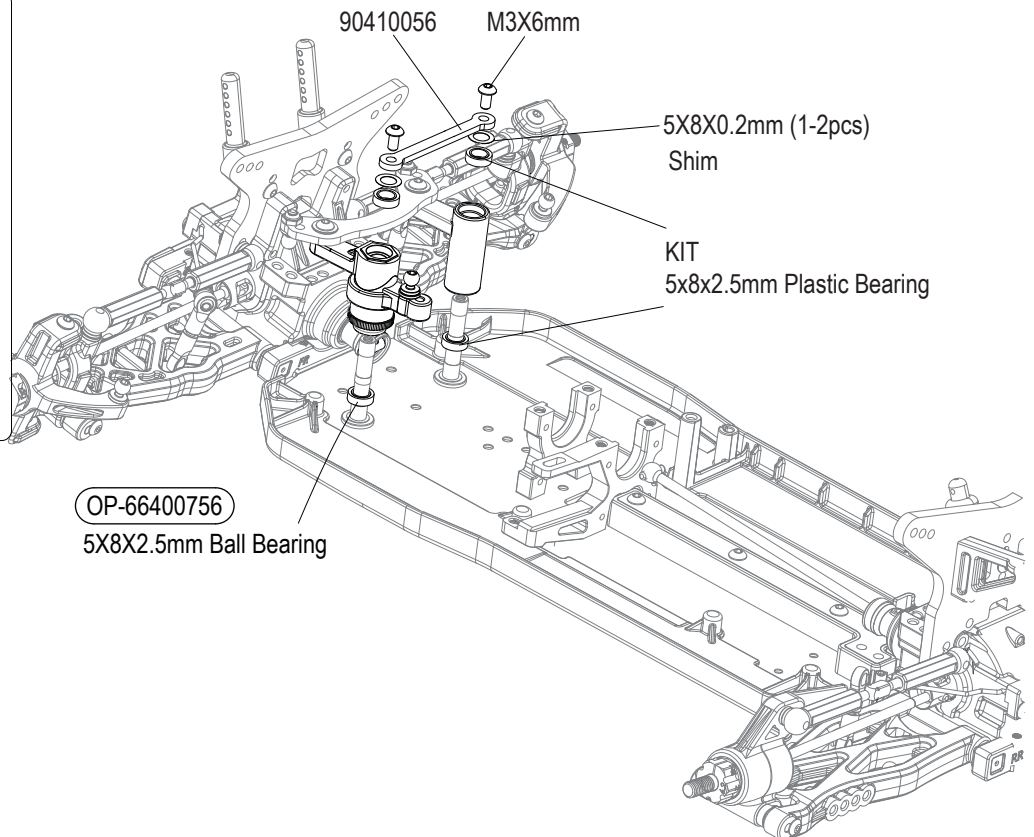



## D3 Turnbuckle Assembly-Steering Rod -Servo Rod

BAG D

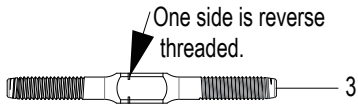

36mm Turnbuckles  
 KIT-66400346 (Black)  
 OP-77430016 (Silver)

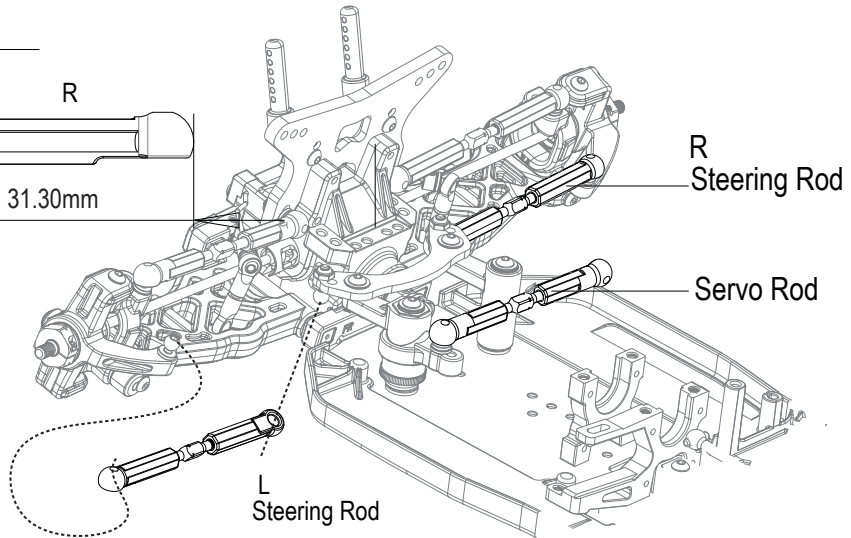
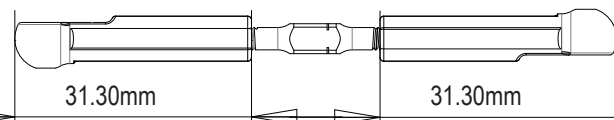
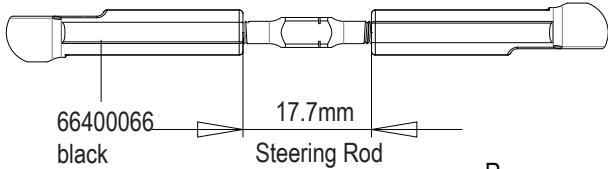
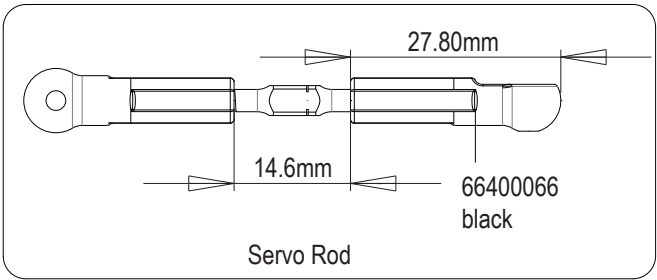

## D4 Steering Servo

BAG D

4  
 M3X6mm 80400026

4  
 M3X10mm 80400046

1  
 M3x10mm 82400106

3  
 M3X8mm 82400026

1  
 M3 Lock Nut  
 83400026

1  
 68430086  
 4.8x6mm-0.8mm

4  
 Silver Aluminum Spacer  
 3x6.6x1mm-85440310

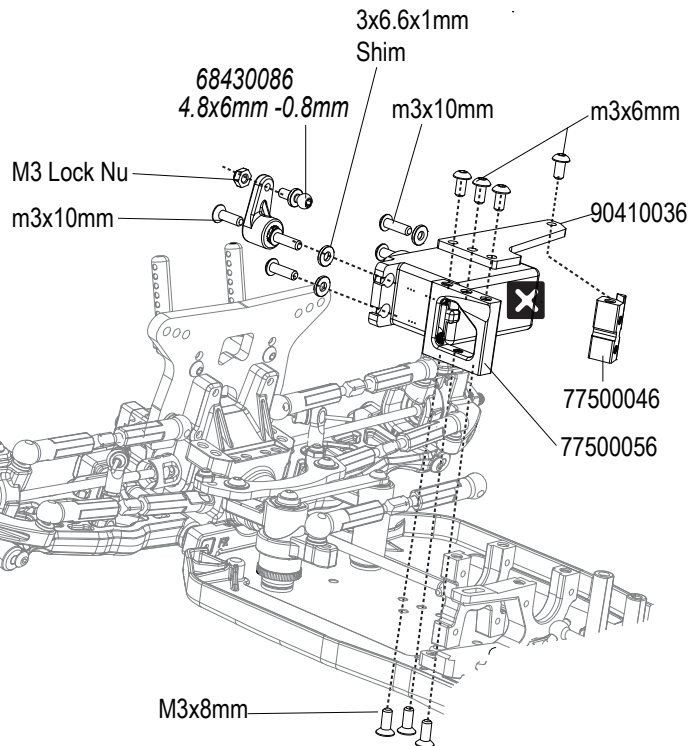

KIT  
 Servo  
 Installation  
 66402466

|     |     |        |
|-----|-----|--------|
|     |     |        |
| KO  | JR  | Futaba |
| 23T | 25T |        |

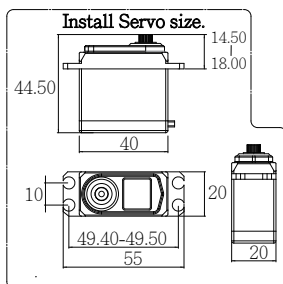

attaching the servo saver horn.  
 (Refer to your radio manual for more information)  
 Select the servo saver adapter  
 matching the servo being used.

## D5 Center Mount Plate

BAG  
D

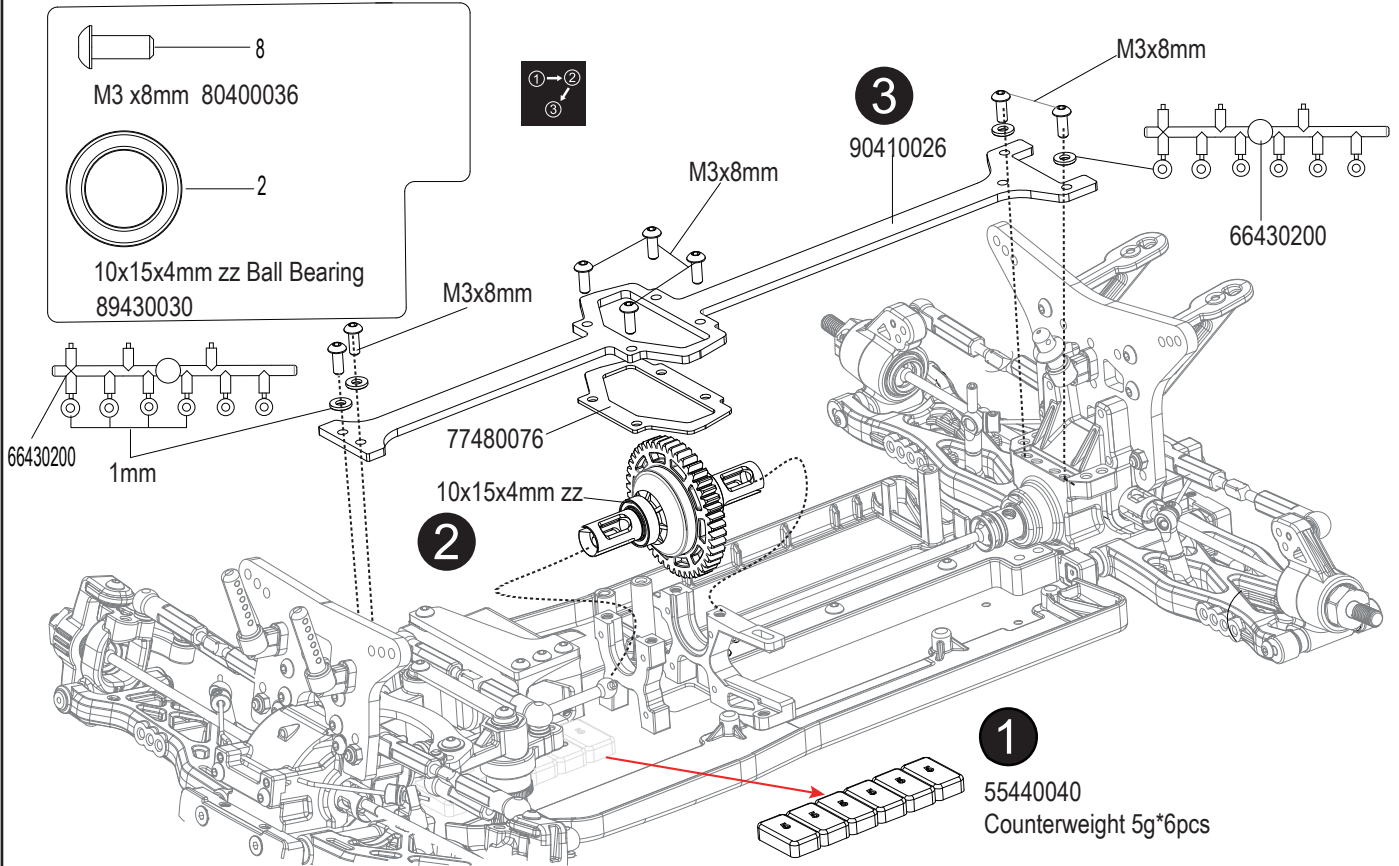

## D6 Battery Plate Installation

BAG  
D

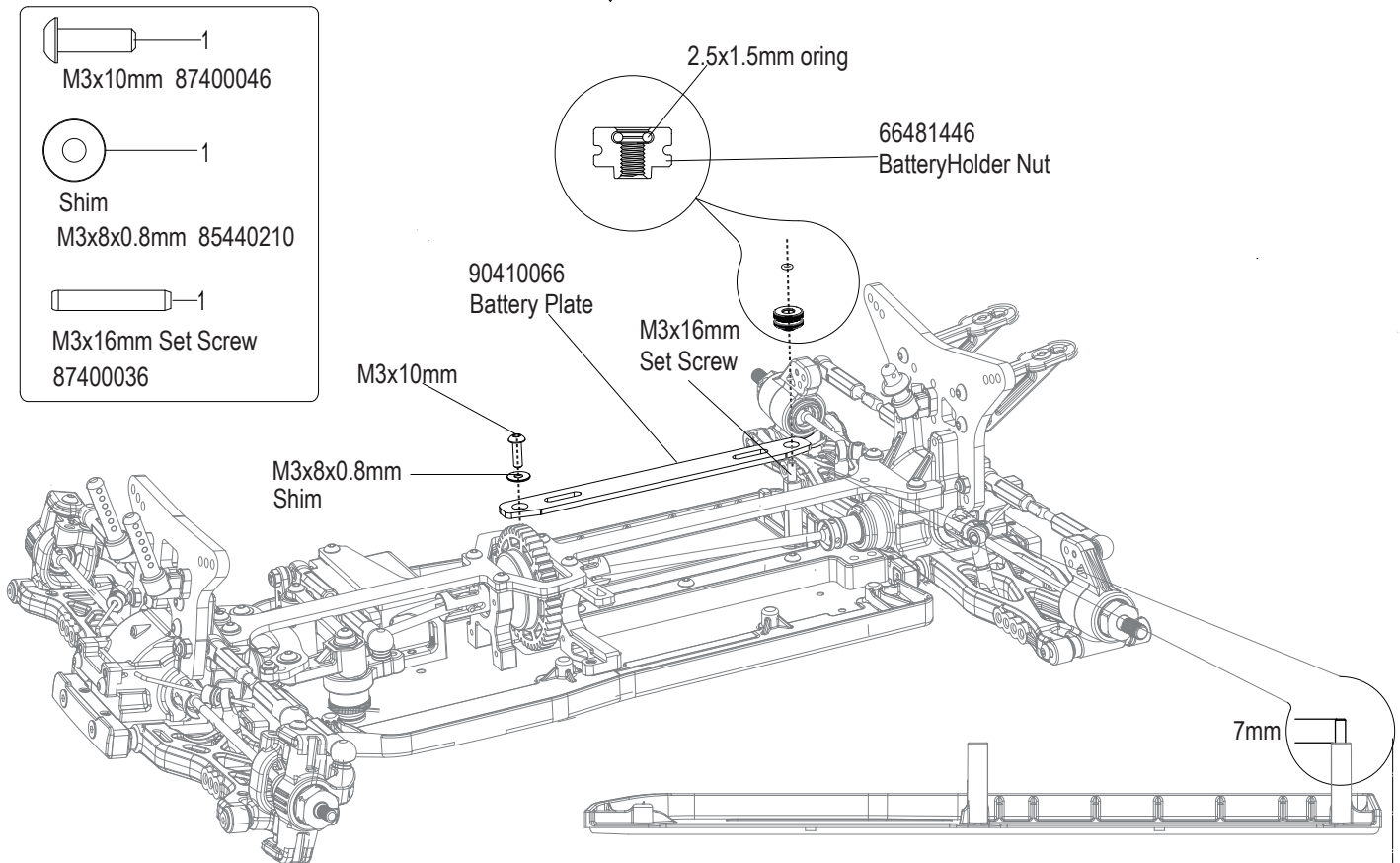



# E1 Front & Rear Shock Assembly-R

## Aluminium Shock Kit

Assemble 2 front and 2 rear shocks

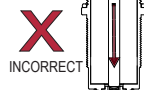
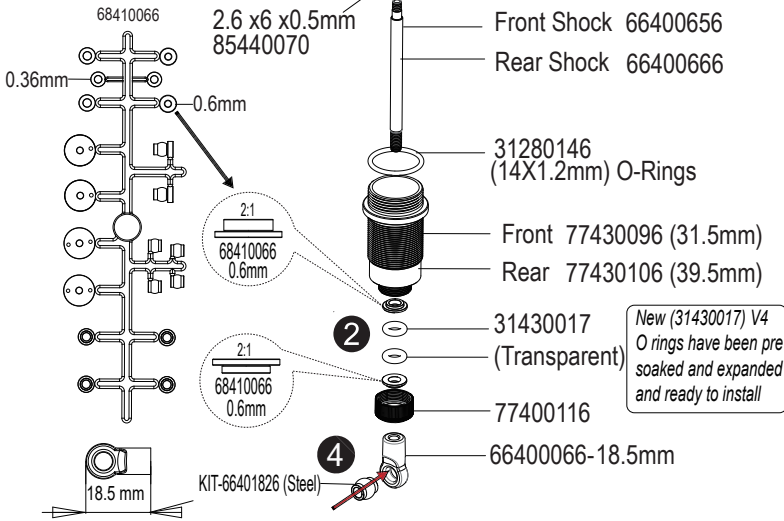

**EXTREMELY IMPORTANT**  
Do not push the shock rod straight through the lower shock body assembly; O-ring damage may result.



Twist the shock rod through the lower shock body assembly.

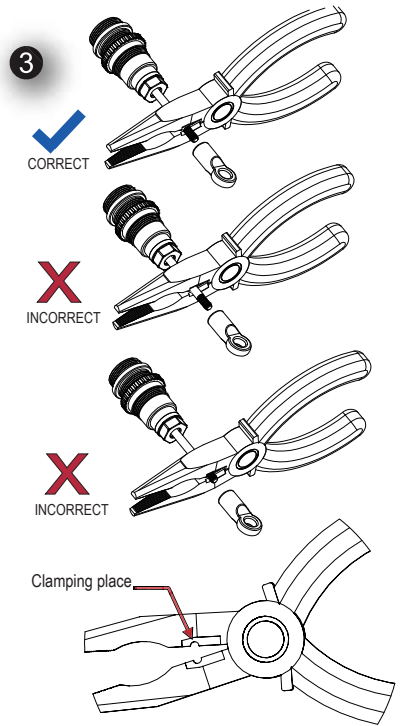

## E1.1

After first drive adjust for track conditions

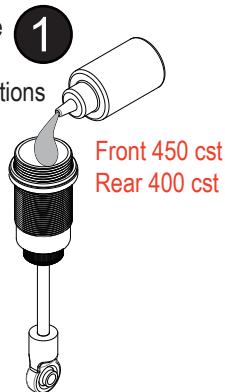

Front Build x2

Slowly move up and down to remove air bubbles.

Length  
Front -25.7mm  
Rear -31.0mm

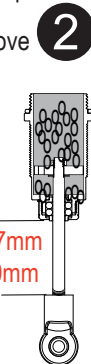

Rear Build x2

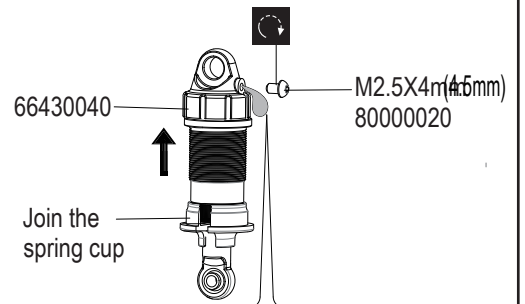

3

Slowly push the shock shaft all the way up, wipe away any excess oil that has seeped out, and screw in the bleeder screw.



## E1.2

2019 PR 1/10 Type R Shock Spring

71530016-Type R Front Shock Spring Set (Not included-02530016)

| PART NO: | Color        | kg/mm      | lbs/in    |
|----------|--------------|------------|-----------|
| 02500096 | Transparent  | 0.053      | 2.97      |
| 02500106 | Blue         | 0.058      | 3.25      |
| 02500146 | White        | 0.061      | 3.42      |
| 02500116 | Red          | 0.063      | 3.53      |
| 02500126 | Yellow       | 0.068      | 3.81      |
| 02530016 | Green        | 0.075      | 4.20      |
| 02530026 | Black        | 0.080      | 4.48      |
| 02530036 | Blue Red     | 0.085      | 4.76      |
| 02530046 | White Yellow | 0.090      | 5.04      |
| 02530116 | Green Black  | 0.098-(RT) | 5.88-(RT) |

71530026-Type R Rear Shock Spring Set (Not included-02530126)

| PART NO: | Color        | kg/mm      | lbs/in    |
|----------|--------------|------------|-----------|
| 02500056 | Transparent  | 0.030      | 1.80      |
| 02500066 | Blue         | 0.035      | 2.10      |
| 02500136 | White        | 0.037      | 2.22      |
| 02500076 | Red          | 0.040      | 2.40      |
| 02500086 | Yellow       | 0.045      | 2.70      |
| 02530056 | Green        | 0.050      | 3.00      |
| 02530066 | Black        | 0.055      | 3.30      |
| 02530076 | Blue Red     | 0.060      | 3.60      |
| 02530086 | White Yellow | 0.065      | 3.90      |
| 02530126 | Green Black  | 0.073-(RT) | 4.50-(RT) |

OP



4

Front Build x2

7.8mm

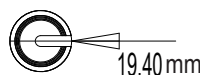
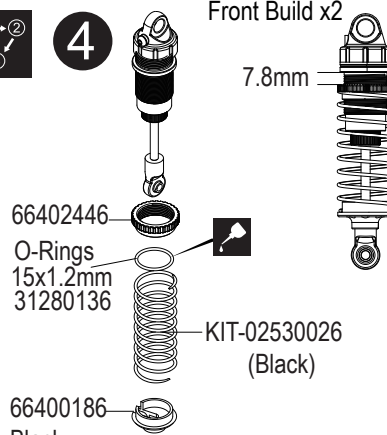

Rear Build x2



6.7mm

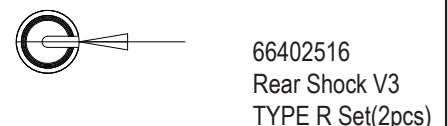
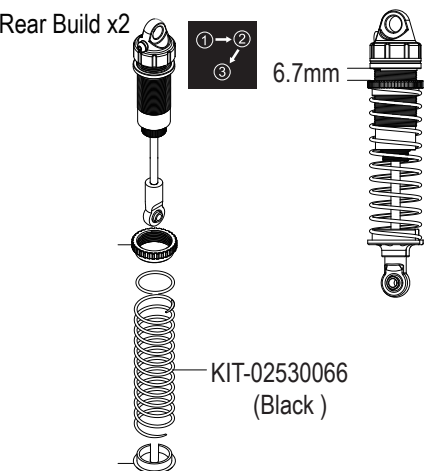

Part Bags used.



Apply threadlocker (screw cement)



Do not over tighten.



Apply oil.



Assemble in the specified order.

## E2 Front & Rear Shock Installation

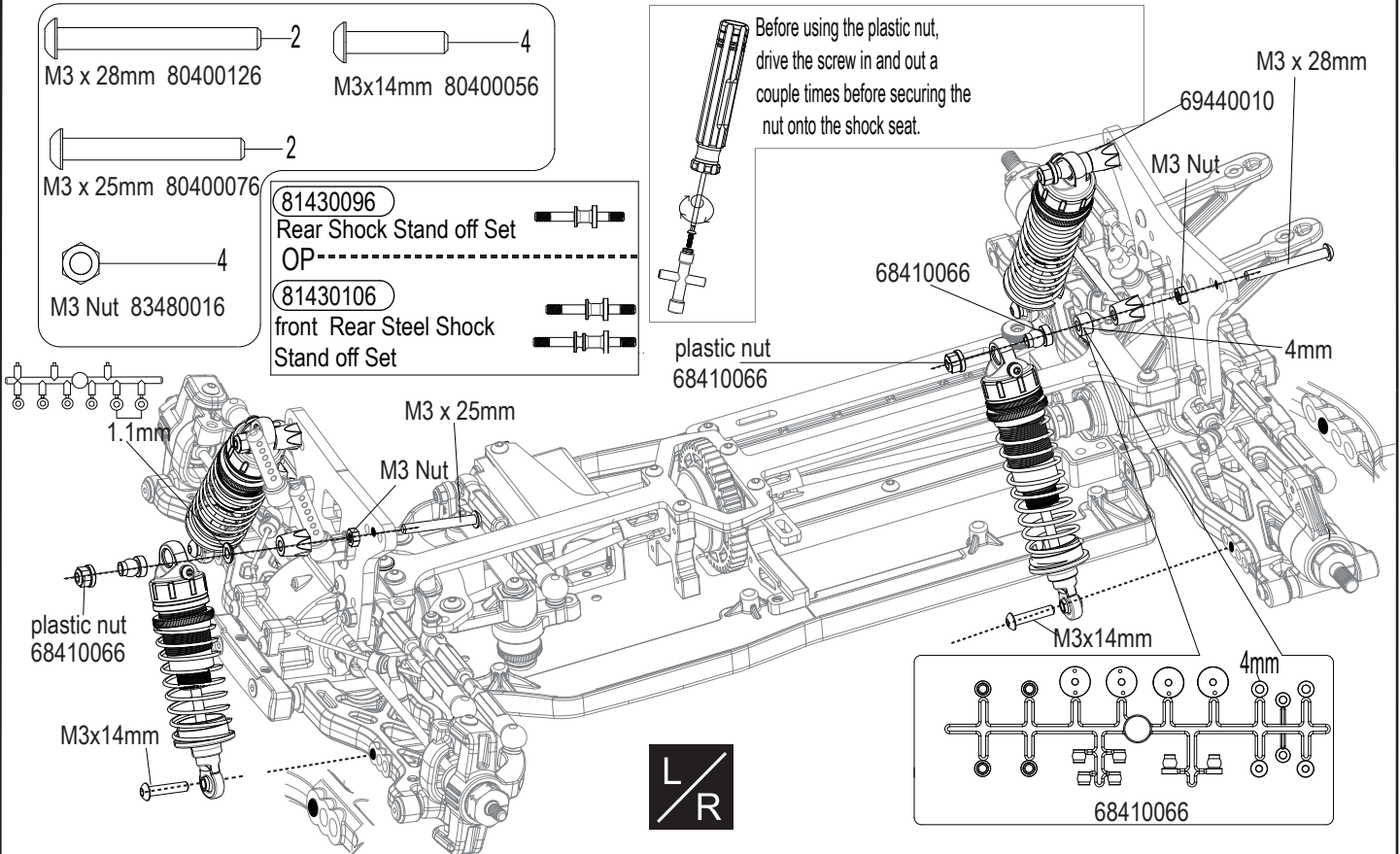

## E3 Motor Installation

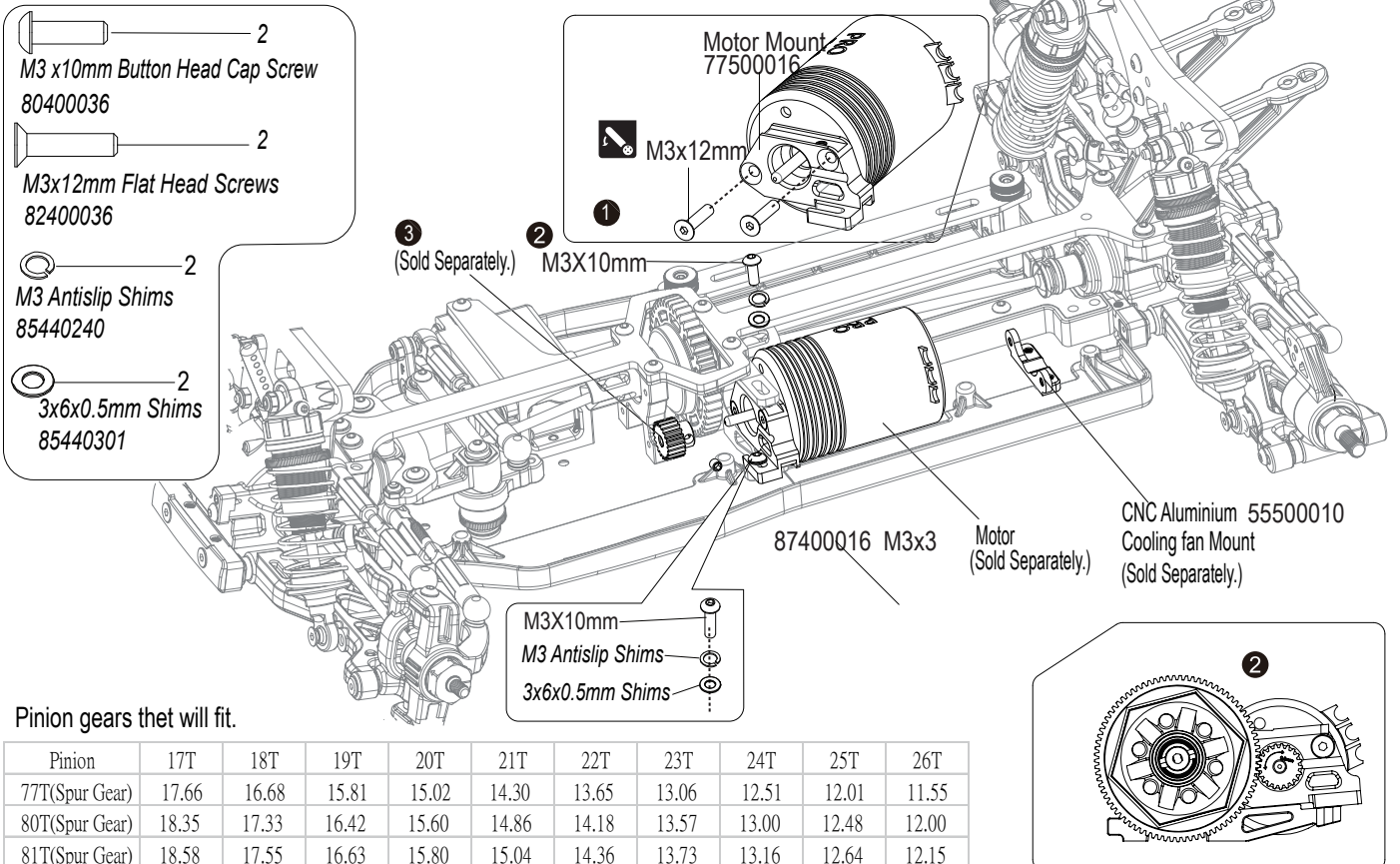



# E4 Mounting Tires Wheel Installation

2  
M3x8mm Flat Head Screws  
82400026

4  
83400086-M5

3  
R6-66401926

67410216 67410226

67410466  
(Sold Separately.)

32430976  
(Sold Separately.)

67410086  
(Sold Separately.)

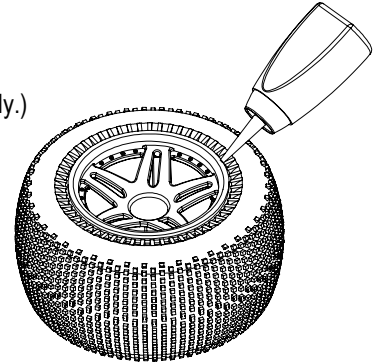
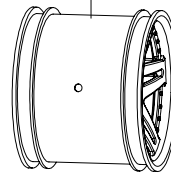
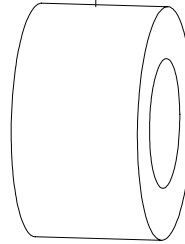
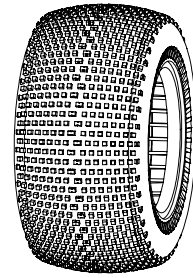

\*Place the tire insert into the tire and tire onto the wheel.

\*Tire and insert (Sold separately)

CA(Cyanoacrylate) glue sold separately.

\*Pull the sidewall of the tire slightly away from the rim and apply CA(Cyanoacrylate) glue in between the tire bead and rim

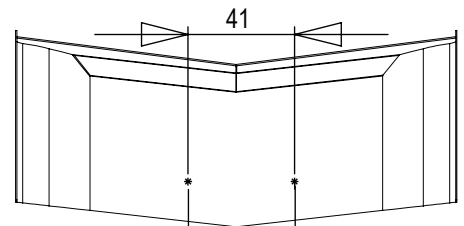

## Body and Wing Cutting

\*Wash the inside of the body with luke warm water and a mild soap or detergent (such as liquid dishwashing soap) prior to painting. Oil residue or dust will prevent the paint from adhering to the painting surface, and possibly cause the paint to peel later on. After washing, thoroughly dry the body to allow the paint to adhere properly.

66401926-R6 Snap Pin

Drilling 6mm

90410016

Battery separator  
77500276

Drilling-6mm

M3x8mm

kit-68480036  
OP-85430016 (Aluminum)  
Wing Mount Washer

Kit-66401606 0.8x170mm  
OP-66400286 1.0x170mm  
OP-66401726 1.2x170mm  
OP-66402706 2.0x170mm  
OP-66401626 1.0x150mm

OP-55500010  
Aluminium -CNC  
Cooling fan Mount  
(Sold Separately.)

98400016  
Antenna Tube

Cut off portion.

(Sold Separately)  
67410086

KIT-83400086-M5 Steel 8mm Hex  
OP-83400116 M5 Serrated flange nut 7mm Hex

# PR SB401RT SPORT

PR SB401RT SPORT 1/10 Electric 4wd Off Road Turggy Kit  
ITEM NO:77500406

## CIRCUIT

- INDOOR  OUTDOOR  DIRT  ASTROTURF  CARPET  
 GLASS  WOOD  WET  DRY  DUSTY  SMOOTH  
 BUMPY  HARD PACKED  CLAY  BLUE GROOVE  
 LOW TRACTION  MED TRACTION  HIGH TRACTION

DRIVER

DATE

### FRONT

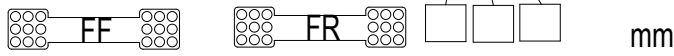
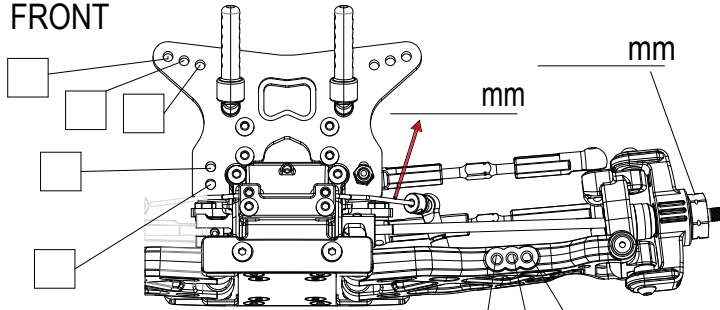

Ride Height

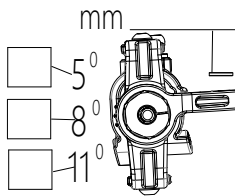

Shock Body

- 12.0mm  
 12.8mm

Pom Shim

- 0.36mm  
 0.6mm

|          |   |
|----------|---|
| Oil      |   |
| Pisyons  | Holes mm  |
| Downstop | Shim mm   |
| Up stop  | Shim mm   |
| Length   | mm  |
| O Rings  | <input type="checkbox"/> transparent <input type="checkbox"/> Red |

|                     |    |
|---------------------|----|
| Camber              |    |
| Ride Height         | mm |
| TOE In Out          |    |
| Type R Shock Spring |    |

### REAR

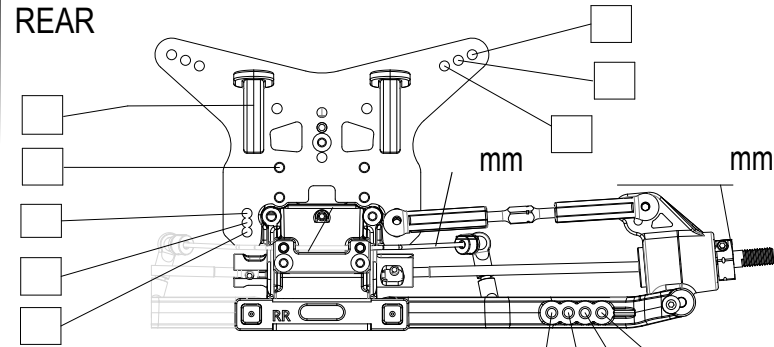

Ride Height

Camber

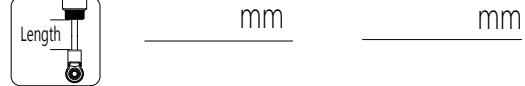

Shock Body

- 12.0mm  
 12.8mm

Pom Shim

- 0.36mm  
 0.6mm

|          |   |
|----------|---|
| Oil      |   |
| Pisyons  | Holes mm  |
| Downstop | Shim mm   |
| Up stop  | Shim mm   |
| Length   | mm  |
| O Rings  | <input type="checkbox"/> transparent <input type="checkbox"/> Red |

|                     |    |
|---------------------|----|
| Camber              |    |
| Ride Height         | mm |
| TOE In              |    |
| Type R Shock Spring |    |

MOTOR \_\_\_\_\_

GEAR Spur \_\_\_\_\_ T \_\_\_\_\_

Pinion \_\_\_\_\_ T \_\_\_\_\_

BATTERY \_\_\_\_\_

ESC \_\_\_\_\_

FRONT TIRE \_\_\_\_\_

INSERTS \_\_\_\_\_

WHEELS \_\_\_\_\_

REAR TIRE \_\_\_\_\_





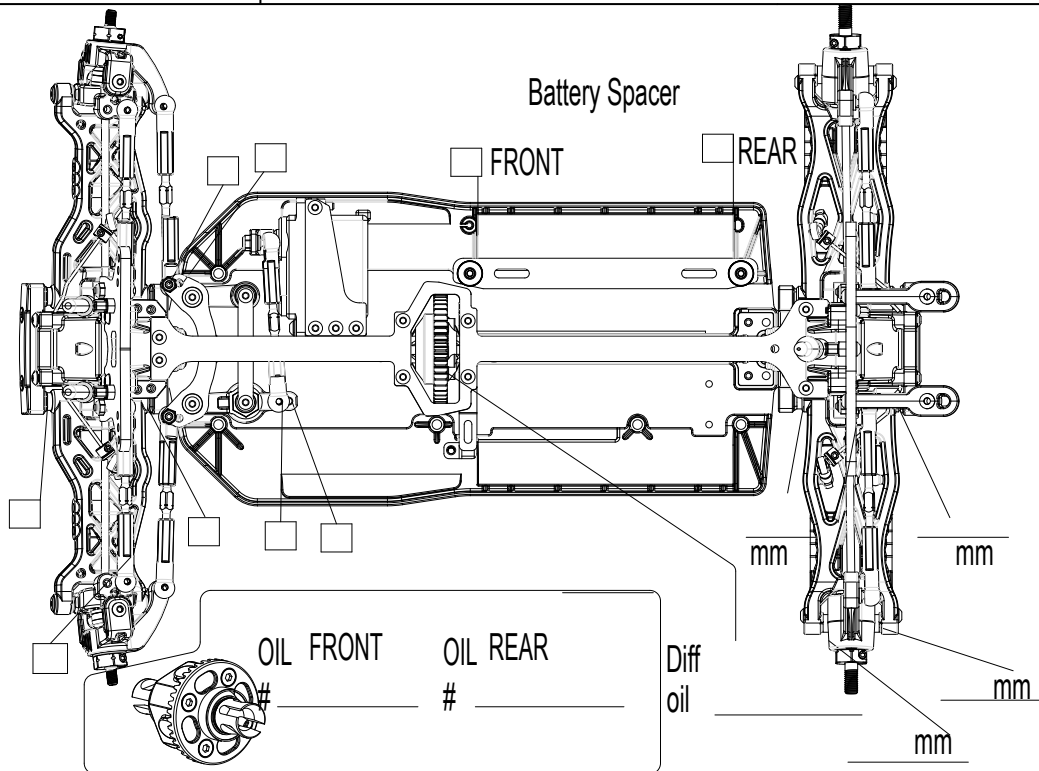





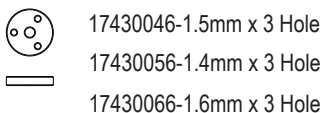
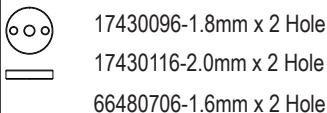
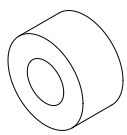
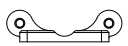
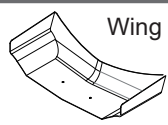
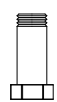

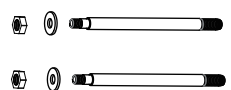
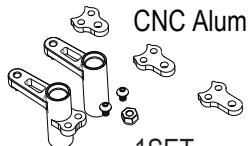
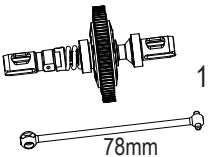
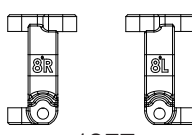
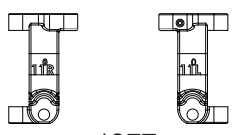

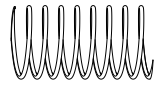
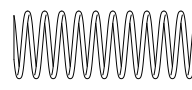
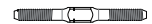
INSERTS \_\_\_\_\_

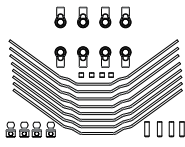
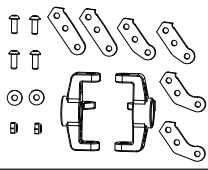
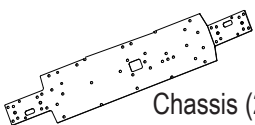
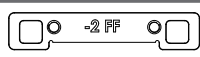
WHEELS \_\_\_\_\_

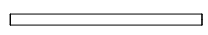
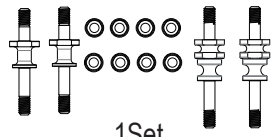
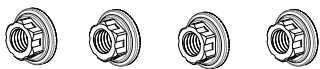

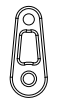
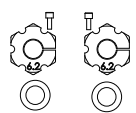
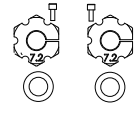
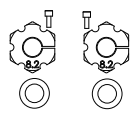
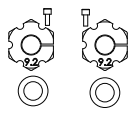
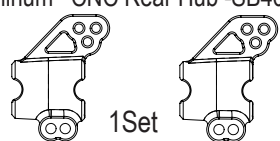
OTHER \_\_\_\_\_

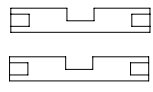

|  |   |   |   |
|--|---|---|---|
| <p>Machined Shock Pistons</p>  <p>17430046-1.5mm x 3 Hole<br/>17430056-1.4mm x 3 Hole<br/>17430066-1.6mm x 3 Hole<br/>4PCS 17430076-1.7mm x 3 Hole</p> | <p>Machined Shock Pistons</p>  <p>17430096-1.8mm x 2 Hole<br/>17430116-2.0mm x 2 Hole<br/>66480706-1.6mm x 2 Hole<br/>4PCS 66480716-1.7mm x 2 Hole</p> | <p>32430976</p>  <p>2.2" Truggy Foam Tire Inserts<br/>2PCS</p> | <p>55500010</p>  <p>Cooling fan Mount<br/>1PCS</p> |
| <p>66401726</p>  <p>Wing (1.2mm)<br/>1PCS</p>   | <p>66402256</p>  <p>1PCS</p>   | <p>66402266</p>  <p>1PCS</p>                                   | <p>77410016</p>  <p>2PCS Front Shock +2mm</p>      |
| <p>66481256</p>  <p>CNC Aluminium<br/>1SET</p>  | <p>77500506</p>  <p>1SET<br/>78mm</p>  | <p>68480866</p>  <p>1SET</p>                                  | <p>68480976</p>  <p>1SET</p>                       |
| <p>68481016</p>  <p>Aluminum<br/>1PCS</p>   | <p>71530016</p>  <p>Type R Front Shock Spring Set</p>  | <p>71530026</p>  <p>Type R Front Shock Spring Set</p>         | <p>77430016</p>  <p>alloy steel<br/>6PCS 36mm</p>  |
| <p>77430056</p>  <p>alloy steel<br/>2PCS 50mm</p>   | <p>77480136</p>  <p>Sway Bar Set<br/>1SET</p>  | <p>77480160</p>  <p>Aluminum Steering Knuckles<br/>1SET</p> | <p>77500286</p>  <p>Chassis (2.0mm)<br/>1pcs</p> |
| <p>77510010</p>  <p>FF Suspension Mount 2mm narrower<br/>1PCS</p>   | <p>77510020</p>  <p>FR Suspension Mount 2mm narrower<br/>1pcs</p>  | <p>79400036</p>  <p>3 x 36.8mm<br/>4pcs</p>                 | <p>79480036</p>  <p>3 x 52mm<br/>4pcs</p>        |
| <p>81430106</p>  <p>1Set</p>   | <p>83400116</p>  <p>4PCS</p>   | <p>85430016</p>  <p>Aluminum Wing Mount Washer<br/>2PCS</p> | <p>68430090</p>  <p>Aluminum<br/>1pcs</p>        |
| <p>90440010</p>  <p>6mm<br/>2PCS</p>  | <p>90440020</p>  <p>7mm<br/>2PCS</p>   | <p>90440030</p>  <p>8mm<br/>2PCS</p>                        | <p>90440040</p>  <p>9mm<br/>2PCS</p>             |
| <p>68000090</p>  <p>Aluminum CNC Rear Hub -SB401<br/>1Set</p>   | <p>66400756</p>  <p>5x8x2.5mm Ball Bearing (6pcs)<br/>6PCS</p>   | <p>66480976</p>  <p>Aluminum<br/>2PCS</p>                   | <p>66400706</p>  <p>Aluminum<br/>4PCS</p>        |

# PR SB40RT

SPORT



EMAIL / [infopracing@gmail.com](mailto:infopracing@gmail.com)

1.1.0.0Version