

# PR SB401R

ITEM NO:77500456

PR SB401R SPORT 1/10 ELECTRIC 4WD OFF-ROAD BUGGY

## SPORT



PR RACING

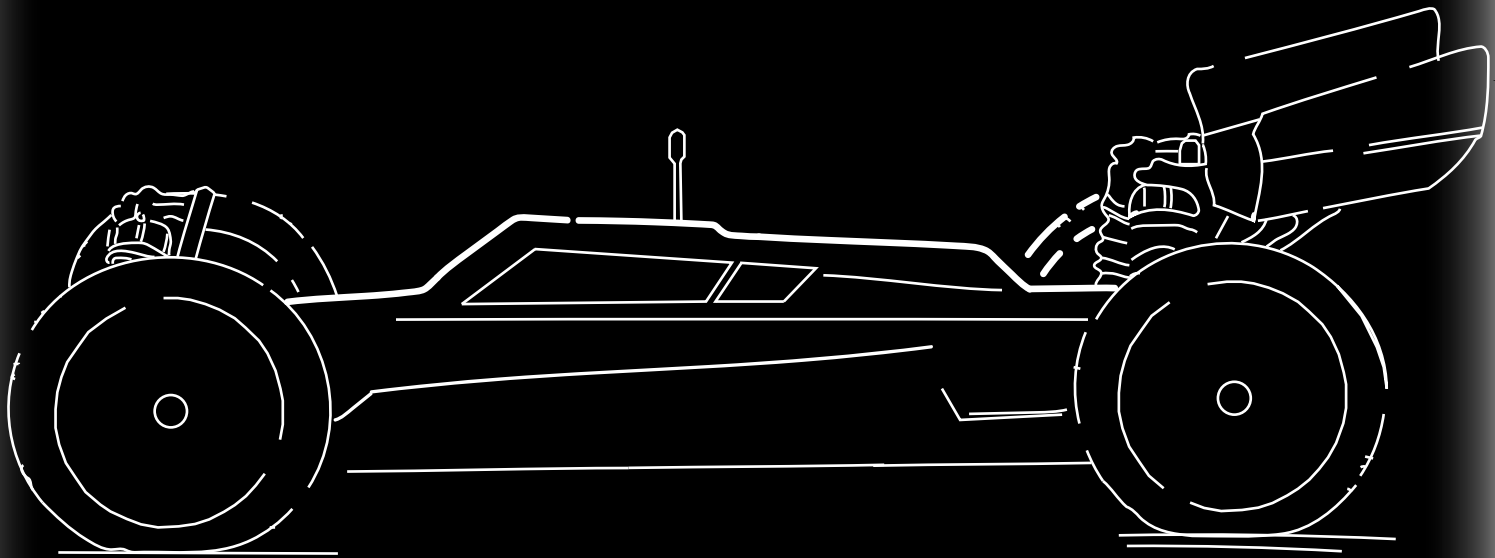

**mit**  
MADE IN TAIWAN

[www.pr-rc.com](http://www.pr-rc.com)

## SAFETY WARNING

This model is a high - performance radio controlled racing product that is designed for use on R/C car race tracks. If it is misused it could cause injury to the operator or others. Many of the items in this kit are small enough to be accidentally swallowed; therefore, it is not suitable for young children. All items, inclusive of liquids, contained in this kit are not intended for human consumption. Rotating parts of the car may cause injury if not handled with care.

Name:PR SB401R SPORT 1/10 ELECTRIC 4WD OFF-ROAD BUGGY

Pr racing has taken all the refinements and changes from the 401R buggy, and applied them to create the 401R ! On top of that we have made further changes specifically for this vehicle to be the most capable, adjustable, durable competition 4x4/ Buggy on the market out of the box! From the aggressive "Low Center of gravity" truggy body, to the "Type R" style shocks and towers. The 401R is ready to dominate on the very first lap!

## Special features

### CHASSIS:

Hard anodized 2.5mm Narrow chassis with side pods deck of added durability.

Alloy/carbon floating servo mount

Type R low center of gravity Buggy style body

## TRANSMISSION

Top loading Center gear differential with ultra hard cups

Updated gear ratio

Longer front and rear gear diff out drives for more droop

## SUSPENSION AND STEERING

12.75mm "LCG" Type R Shocks

Type R "Low mount" Carbon fiber towers

Insert style suspension blocks

3.5 Degree caster blocks

Composite rear hubs with extra pin location for added width adjustability

Gullwing rear arms

High tensile steel turnbuckles

Web link



## SPECIFICATIONS

Type: 1/10th 4wd off-road Buggy

Power: Electric

Wheelbase: Adjustable 284mm to 290mm

Width: Front 250mm Rear 248mm

Gear Ratio: 2:6:1

Weight: 1725grams "Race ready" varies

Hardware: Full metric

Bearings: Sealed metal ball bearings

Wheels: 12mm Hex

Kit: Assembly required

Instruction manual

## ITEM REQUIRED TO COMPLETE

2 Channel surface frequency radio system

2S LiPo battery & compatible LiPo charger

1/10th ESC, 540 brushless motor, pinion gear

High speed servo

1/10th Tires and inserts Wheel

Tools, paint for polycarbonate body, tire glue, and threadlock

Silicon diff and shock oil



- **BEFORE INSTALLATION** ----- 1-2
- **BAG A** ----- 03-07      ● **BAG E** ----- 18 -20
  - A1-Main Chassis Assembly- Chassis Brace Installation
  - A2-Gear Diff Assembly
  - A3-Center Diff
  - A4-Gear Box Assembly
  - A5 Rear Central Transmission
  - E1-Front & Rear Shock Assembly-R
  - E2-Front & Rear Shock Installation
  - E3-Motor Installation
  - E4-Mounting Tires, Wheel Installation
- **BAG B** ----- 08-11
  - B1-Suspension Mount Installation
  - B2-Front Hub Carrier Assembly(Left Side)
  - B3-Suspension Mount Installation-Sway Bar Installation
  - B4-Front Upper Turnbuckle Assembly
- **BAG C** ----- 12-14
  - C1 RF Suspension Mount
  - C2-3-Rear Left Hub Carrier Assmebly
  - C4-Rear Upper Rod -Turnbuckle Assembly
  - C5-Sway Bar Installation
- **BAG D** ----- 15 -17
  - D1-Bell Crank Installation
  - D2- Steering
  - D3-Turnbuckle Assembly-Steering Rod -Servo Rod
  - D4-Servo Installation
  - D5-Center Mount Plate
  - D6-Battery Plate Installation
- **SETUP SHEET** -----21
- **Upgrade Parts** ----- 22

Pinion  
Spur Gear      Must be purchased  
separately.

66480986	PR Racing 48P Pinion (3.17mm ID) (18T)*1pcs	66481576	PR Racing 48P Pinion (3.17mm ID) (26T)*1pcs
66480996	PR Racing 48P Pinion (3.17mm ID) (19T)*1pcs	66481586	PR Racing 48P Pinion (3.17mm ID) (27T)*1pcs
66481006	PR Racing 48P Pinion (3.17mm ID) (20T)*1pcs	66481596	PR Racing 48P Pinion (3.17mm ID) (28T)*1pcs
66400556	PR Racing 48P Pinion (3.17mm ID) (21T)*1pcs	66481606	PR Racing 48P Pinion (3.17mm ID) (29T)*1pcs
66480096	PR Racing 48P Pinion (3.17mm ID) (22T)*1pcs	66481616	PR Racing 48P Pinion (3.17mm ID) (30T)*1pcs
66480106	PR Racing 48P Pinion (3.17mm ID) (23T)*1pcs	66481626	PR Racing 48P Pinion (3.17mm ID) (31T)*1pcs
66480116	PR Racing 48P Pinion (3.17mm ID) (24T)*1pcs	66481636	PR Racing 48P Pinion (3.17mm ID) (32T)*1pcs
66481566	PR Racing 48P Pinion (3.17mm ID) (25T)*1pcs	66481646	PR Racing 48P Pinion (3.17mm ID) (33T)*1pcs
68000100	73T Spur Gear (For SB401)*1pcs		
68400196	75T Spur Gear (For SB401)*1pcs		
68400206	77T Spur Gear (For SB401)*1pcs		
68400216	81T Spur Gear (For SB401)*1pcs		

# TOOLS REQUIRED

**CAUTION: Handle tools carefully!**

- Needle Nose Pliers

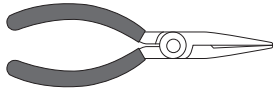

- Awl

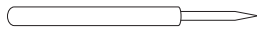

- Sharp Hobby Knife

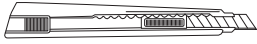

- Hex Wrench



1.5mm

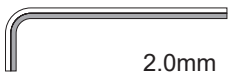

2.0mm

- SILICON DIFF OIL

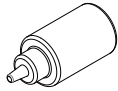

- Grease



- Wire Cutters



- SP Knife Edge Reamer

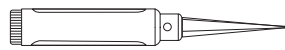

- Do not pre-drill as precise drilling of 1mm to 15mm holes can be performed after body shell painted.

- Screw Cement



- Ball Differential Grease



- Round Cutter & Sander

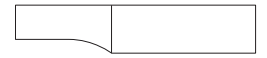
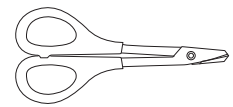

- For trimming bodies Cutting along curved lines was never so easy!

Cross Wrench

- 5.0mm-5.5mm
- 7.0mm

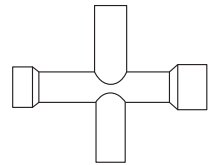

# RADIO PREPARATION

- A new battery must be charged before it is used. Refer to the charger instruction manual for charging.
- Set up the radio control system as indicated below.

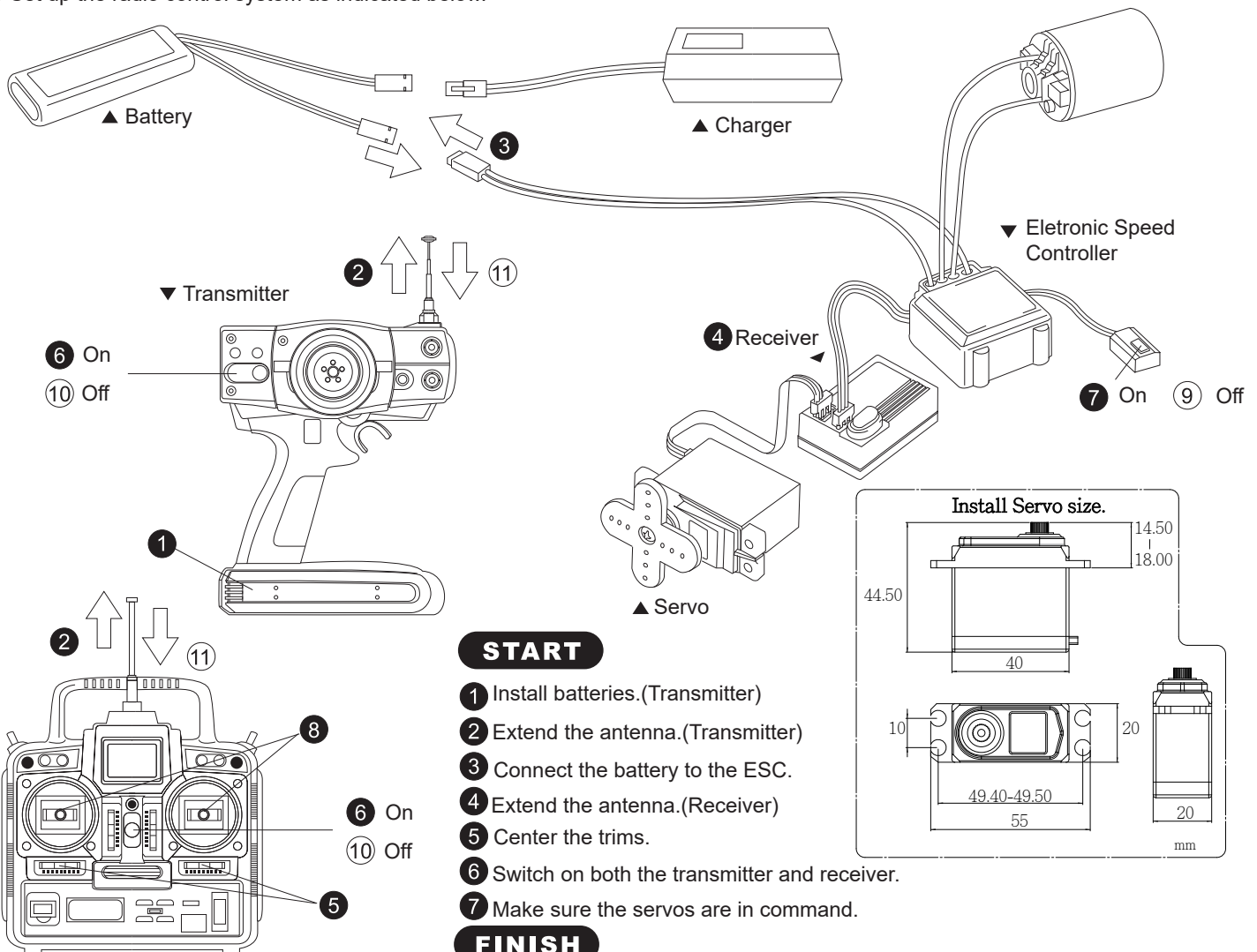

## START

- 1 Install batteries.(Transmitter)
- 2 Extend the antenna.(Transmitter)
- 3 Connect the battery to the ESC.
- 4 Extend the antenna.(Receiver)
- 5 Center the trims.
- 6 Switch on both the transmitter and receiver.
- 7 Make sure the servos are in command.

## FINISH

- 8 Switch off both the transmitter and receiver.
- 9 Retract the antenna.(Transmitter)



# A1 Chassis Brace Installation Main Chassis Assembly

- 6  
M3X6mm  
82400016
- 10  
M3X8mm  
82400026
- 3  
M3X8mm  
80400036

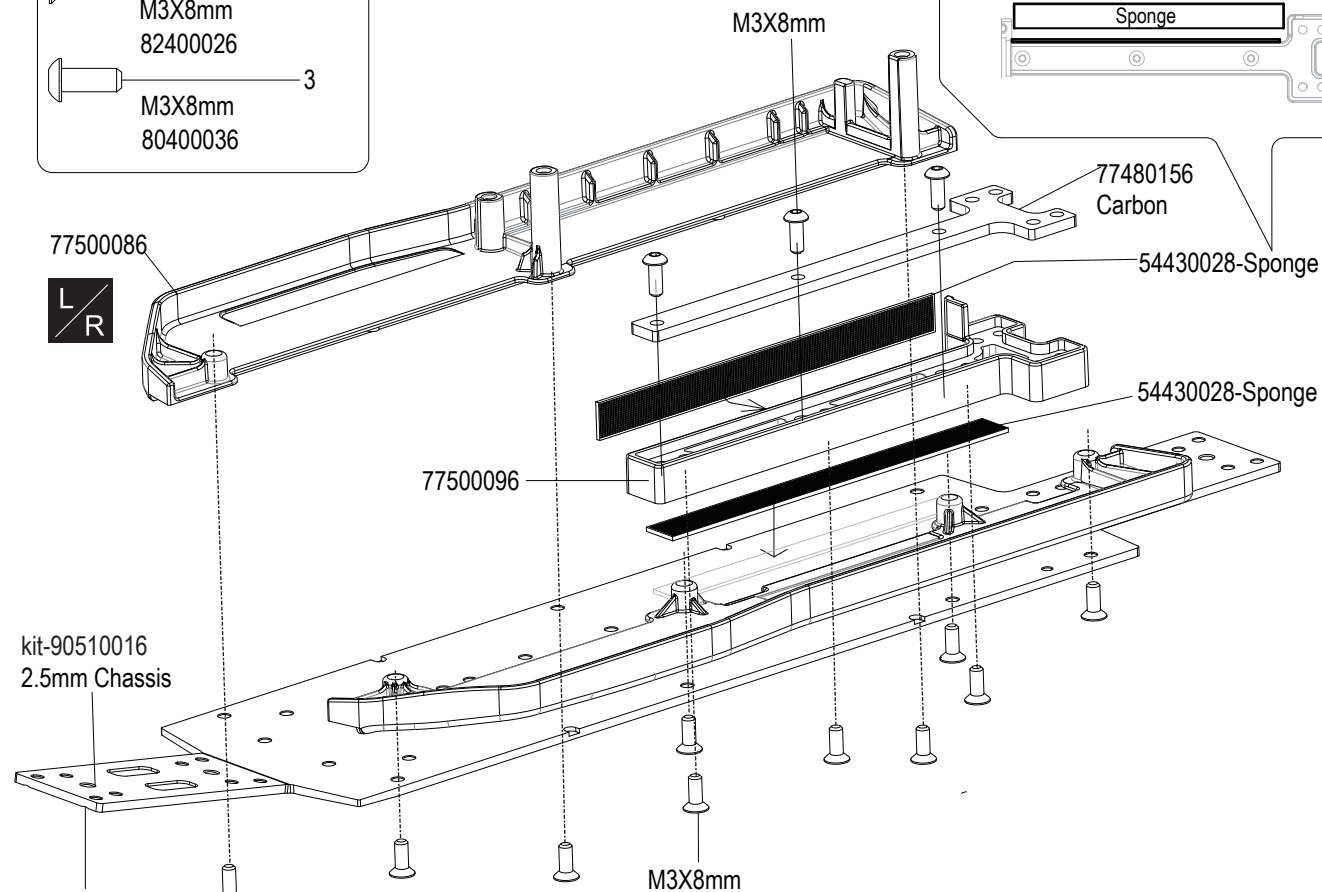
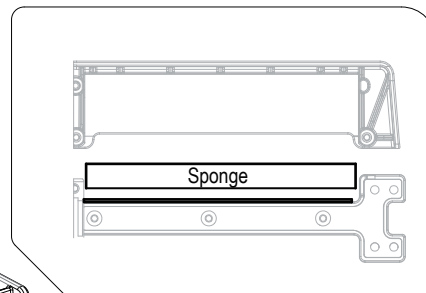

OP-77500286  
2mm Chassis

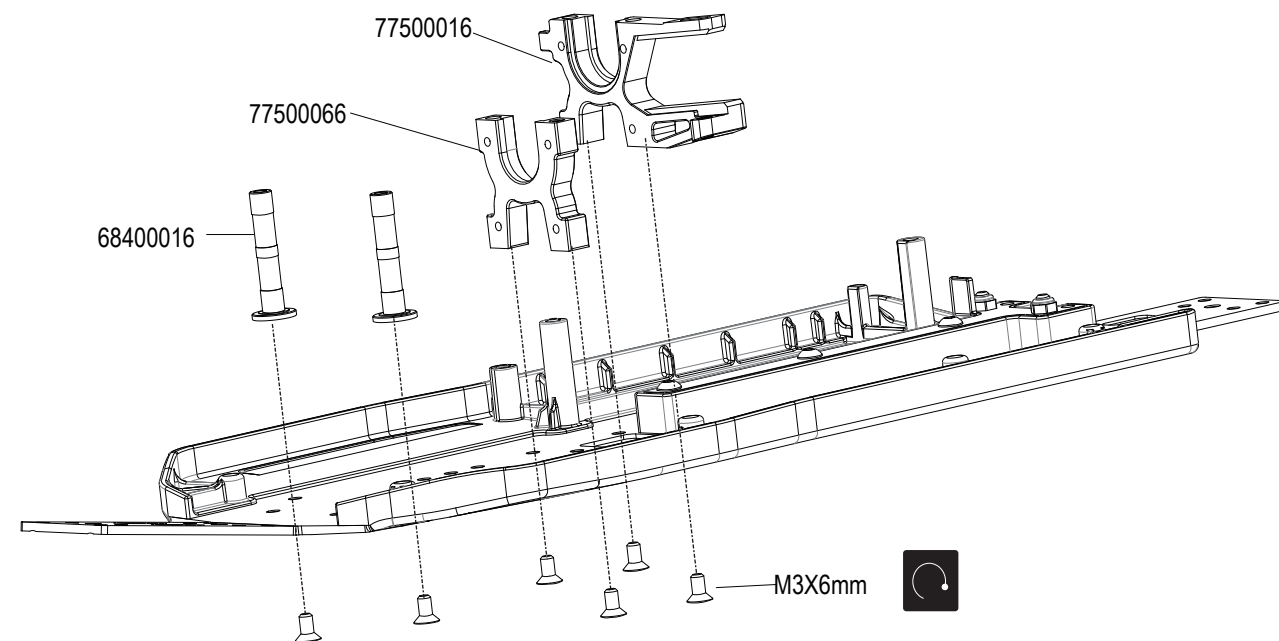

Part Bags used.



Tighten securely.



Assemble left and right sides the same way.



BAG A

# A2 Gear Diff Assembly

- |                                   |                                  |
|-----------------------------------|----------------------------------|
| 8<br>M2.6X10mm<br>82400166        | 4<br>3.5mm<br>85400016           |
| 4<br>5X8x0.8mm Shim<br>85440170   | 4<br>O-ring -5x1.5mm<br>31450016 |
| 8<br>4X10x0.15mm Shim<br>85440160 |                                  |

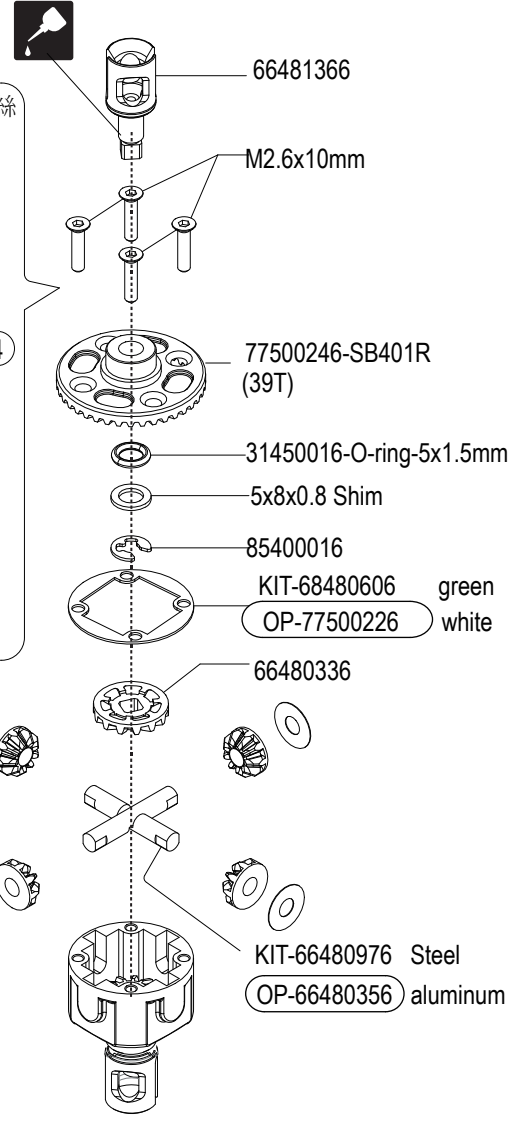
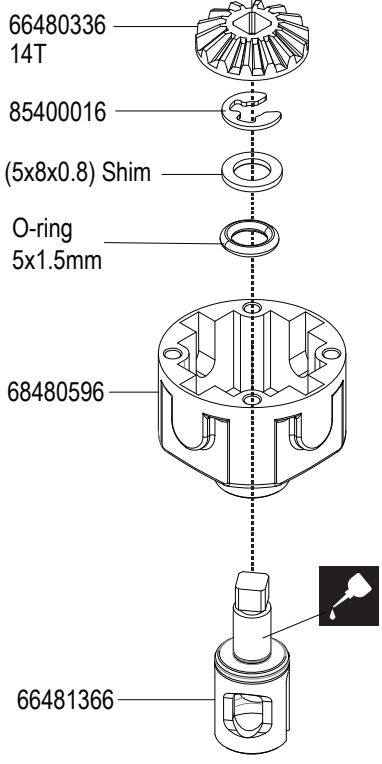
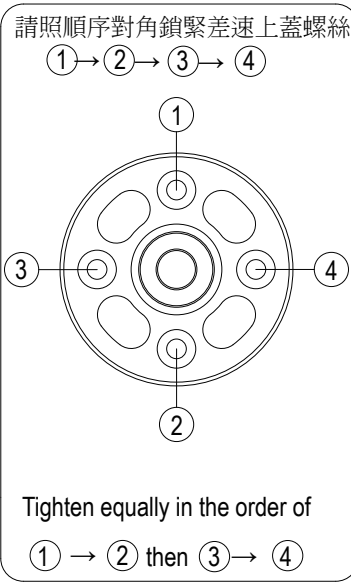

**x2**

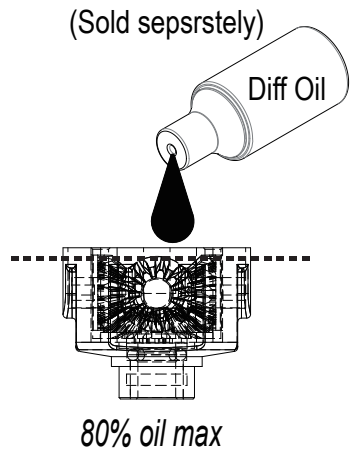

After first drive  
adjust  
for track conditions





SILICON DIFF OIL

7000 Front

5000 Rear

# A3 Center Diff

BAG  
A

- |  |  |
|--|--|
|  4<br>M2.6X10mm<br>82400166       |  2<br>3.5mm<br>85400016           |
|  2<br>5X8x0.8mm Shim<br>85440170  |  4<br>O-ring -5x1.5mm<br>31450016 |
|  4<br>4X8x0.25mm Shim<br>85440150 |  |

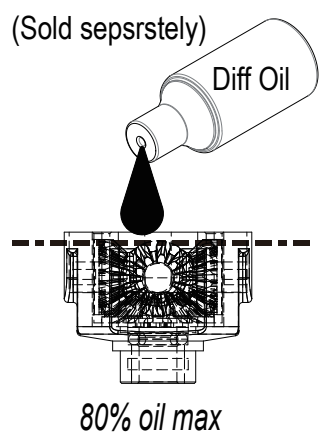
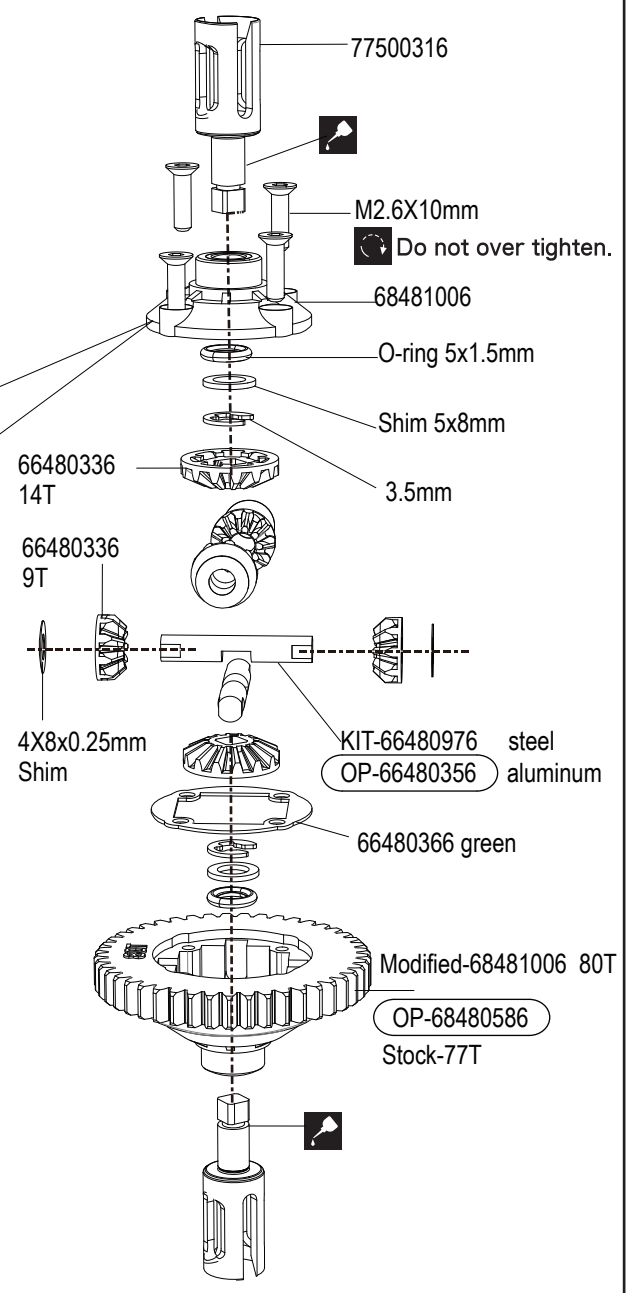
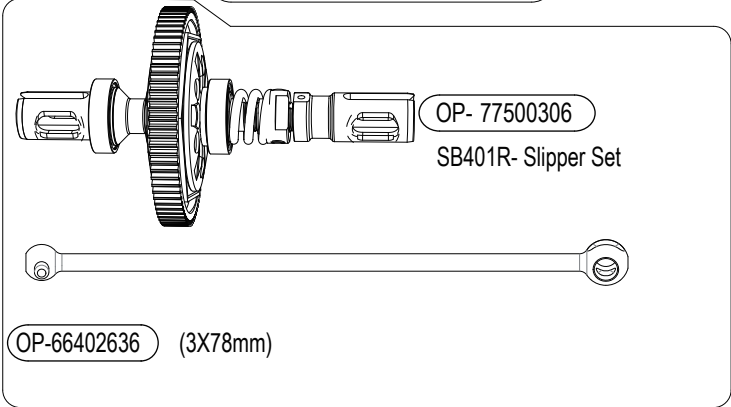
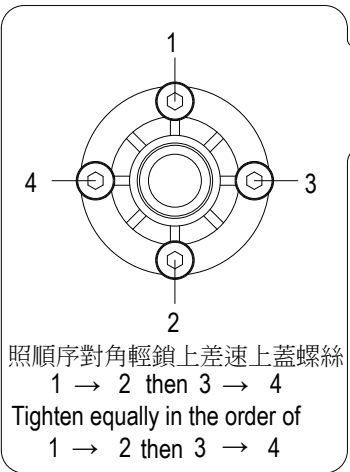

After first drive  
adjust  
for track conditions  
SILICON DIFF OIL  
# 30000- # 50000





BAG A

A4 Gear Box Assembly Front Front Shock Tower nstallation

# Front

2  
4.8x8mm Ball Studs-68430046

2  
M3 Lock Nut 83400026

6  
M3X10mm 80400046

1  
5x8x0.1mm Shim 85440090

3  
10X12.5X0.1Shim 85440230

2  
5x10x4mm Ball Bearing  
89430010

2  
10x15x4mm Ball Bearing  
89430030

1  
(2x9.8mm)79400086

1  
M4X3mm Set Screw 8400016

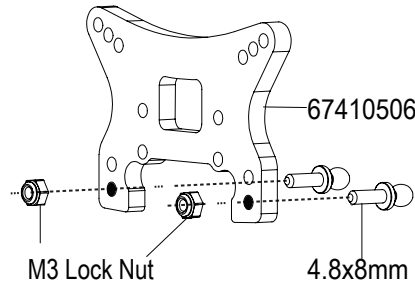

Tighten securely.

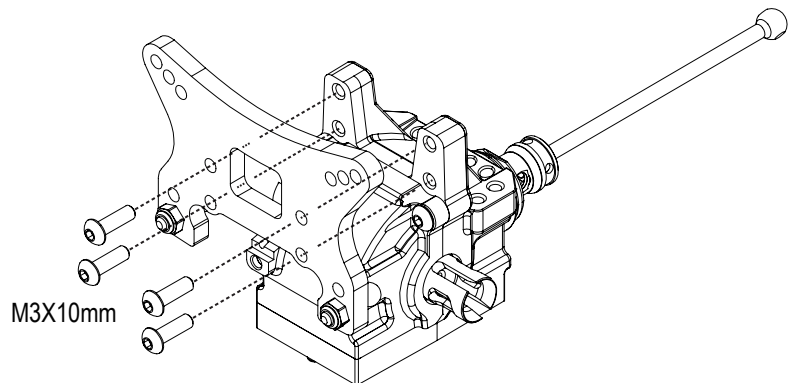
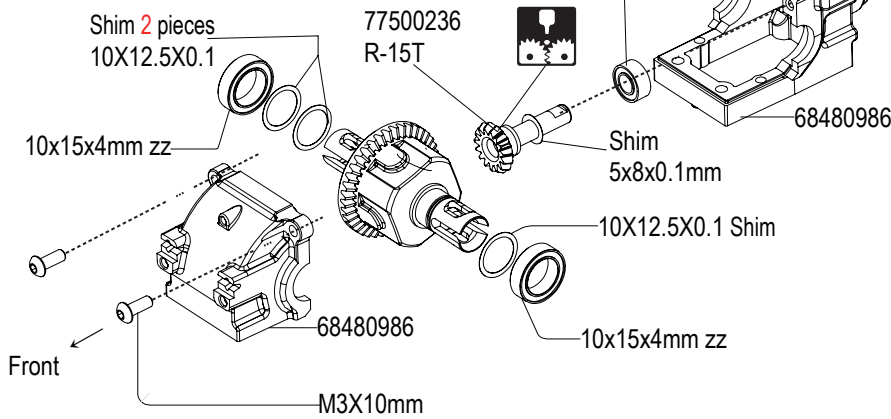
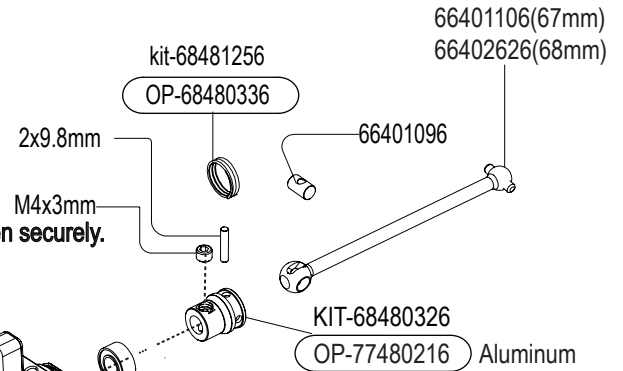



A5 Gear Box Assembly Front Rear Shock Tower Installation

Rear

- 2  
4.8x8mm Ball Studs  
68430046
- 2  
M3 Lock Nut -83400026
- 6  
M3X10mm 80400046
- 1  
M4X3mm Set Screw  
78400016
- 1  
5x8x0.1mm Shim  
85440090
- 3  
10X12.5X0.1 Shim  
85440230
- 2  
5x10x4mm Ball Bearing  
89430010
- 2  
10x15x4mm Ball Bearing  
89430030
- 1  
(2x9.8mm)-79400086

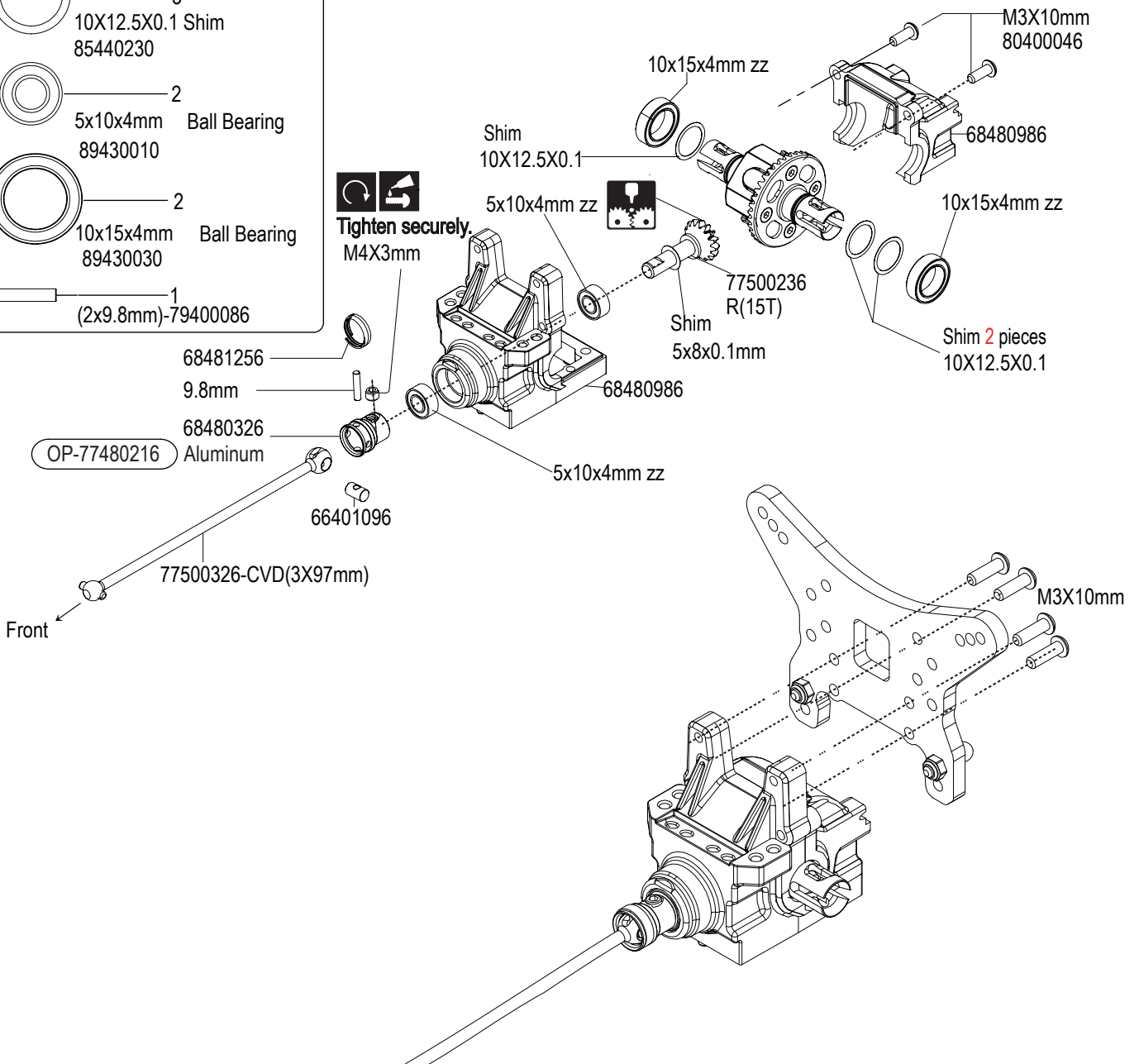
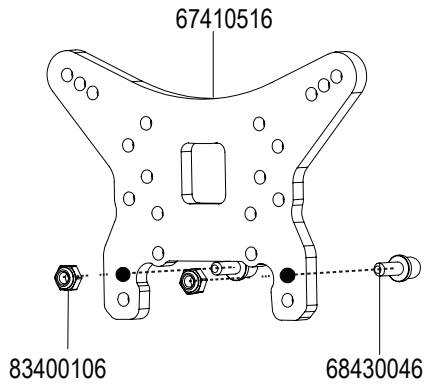



BAG  
B

# B1 Suspension Mount Installation

- 2  
M3 Lock Nut -83400026
- 2  
M3X8mm 82400026
- 2  
M3X10mm 82400106
- 2  
M3X15mm 82400176

Note position-77500156

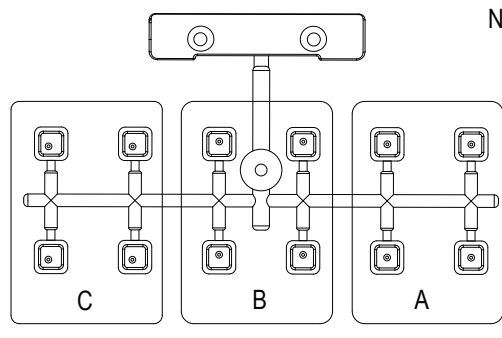

## FRONT HANGER INSERTS

Numbering	FF	FR	TOE	SQUAT
F-1			0	0
F-2			0	+0.7
F-3			0	+1.4
F-4			0	-0.7
F-5			0	0
F-6			0	+0.7
F-7			0	-1.4
F-8			0	-0.7
F-9			0	0
F-10			0	0
F-11			-0.9	0
F-12			-1.7	0
F-13			+0.9	0
F-14			0	0
F-15			-0.9	0
F-16			+1.7	0
F-17			+0.9	0
F-18			0	0
R-19			+3.5	+2

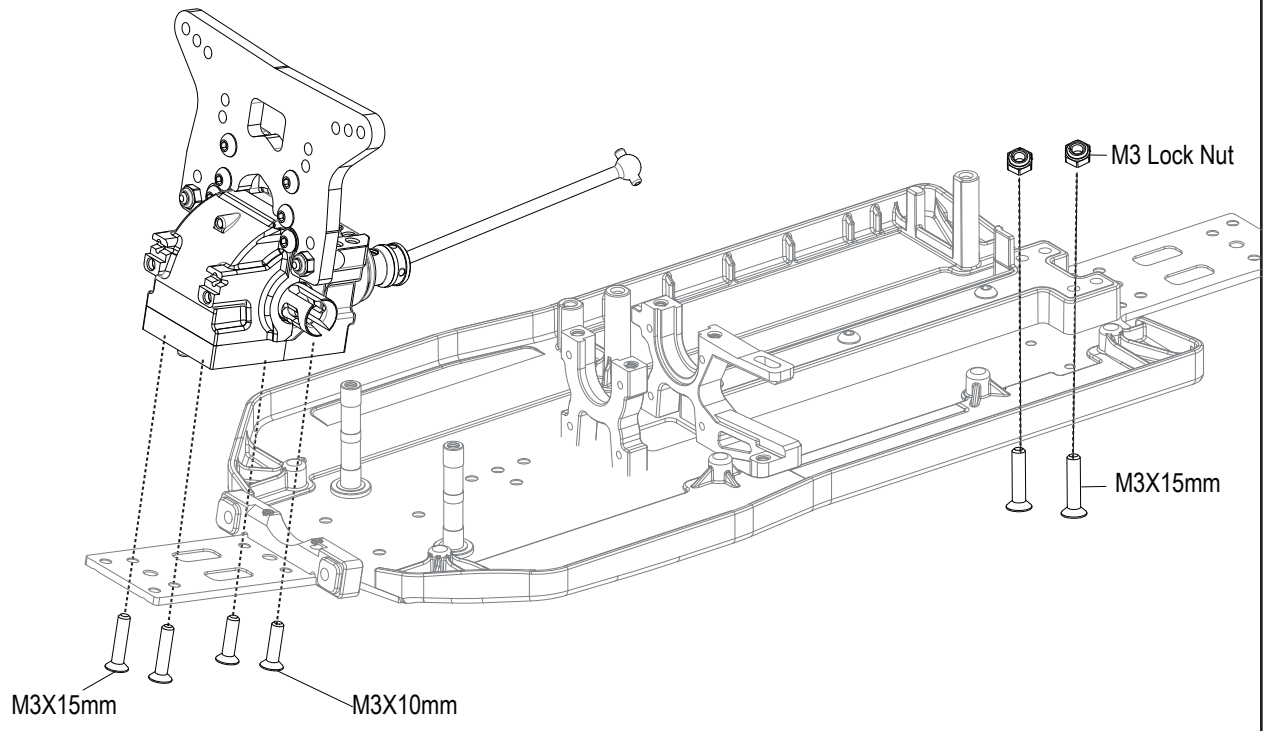
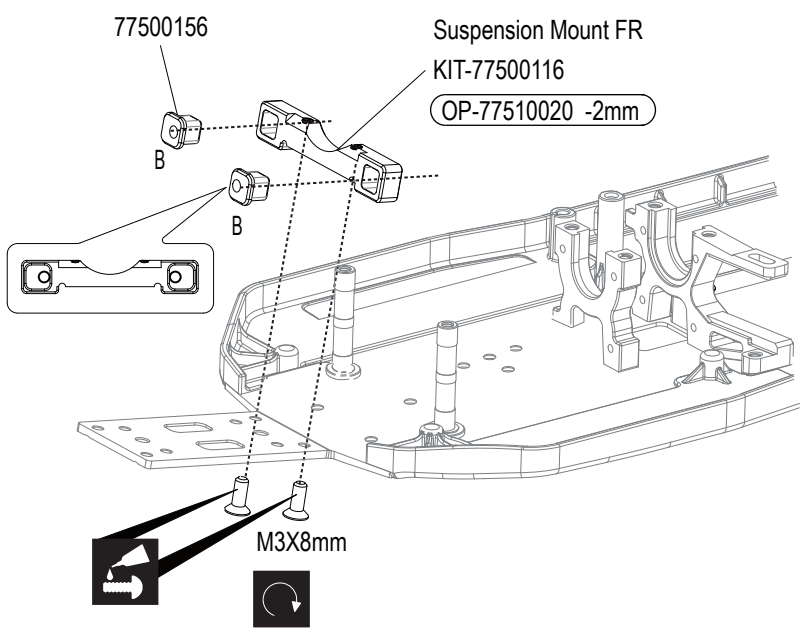

## B2 Front Hub Carrier Assembly (Left Side)

Left Side



- 2  
M3x12mm 80400206
- 2  
4.8mmx6mm 68430036  
Ball Studs
- 1  
5x10x4mm zz Ball Bearing  
89430010
- 1  
5x13x4mm zz Ball Bearing  
89430020
- 1  
Pin 2x9.8mm 79400086
- 1  
Pin 2 x10.8mm-79400016
- 2  
Shim 5x8x0.1mm-85440090
- 1  
m2X5mm-87400066

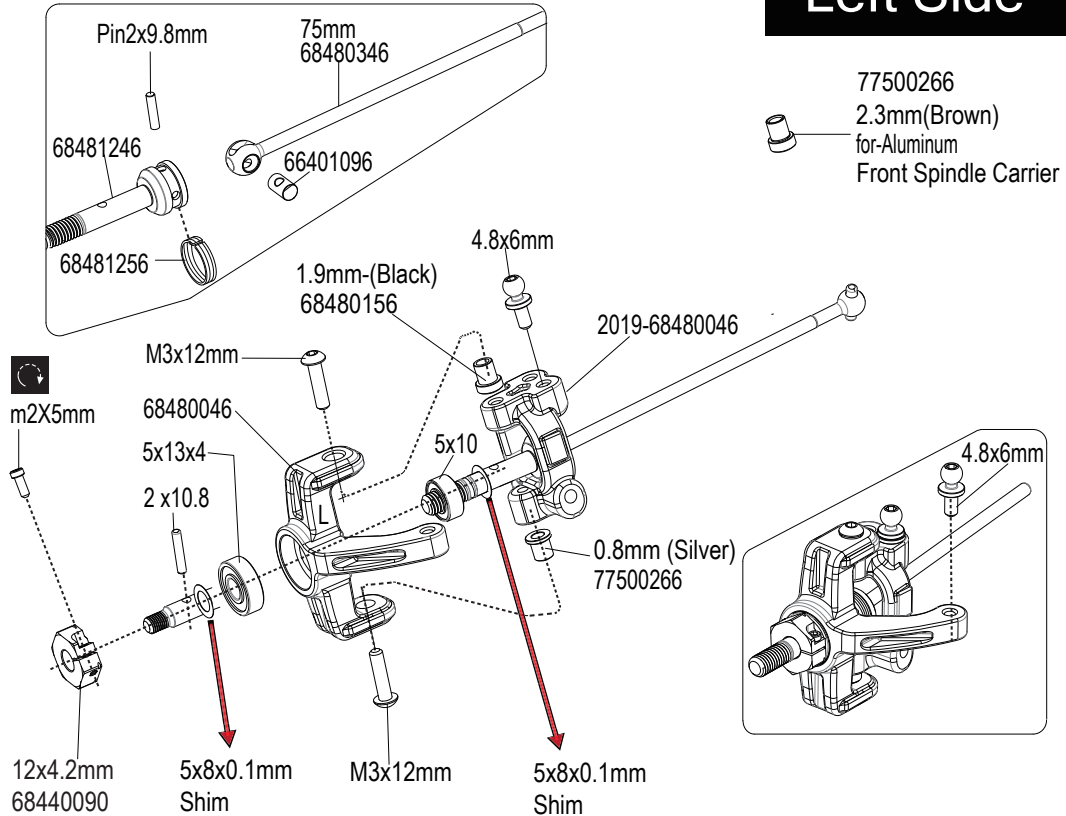

## B3 Front Hub Carrier Assembly (Right Side)

Right Side



- 2  
M3x12mm 80400206
- 2  
4.8mmx6mm 68430036  
Ball Studs
- 1  
5x10x4mm zz Ball Bearing  
89430010
- 1  
5x13x4mm zz Ball Bearing  
89430020
- 1  
Pin 2x9.8mm 79400086
- 1  
Pin 2 x10.8mm-79400016
- 2  
Shim 5x8x0.1mm-85440090
- 1  
m2X5mm-87400066

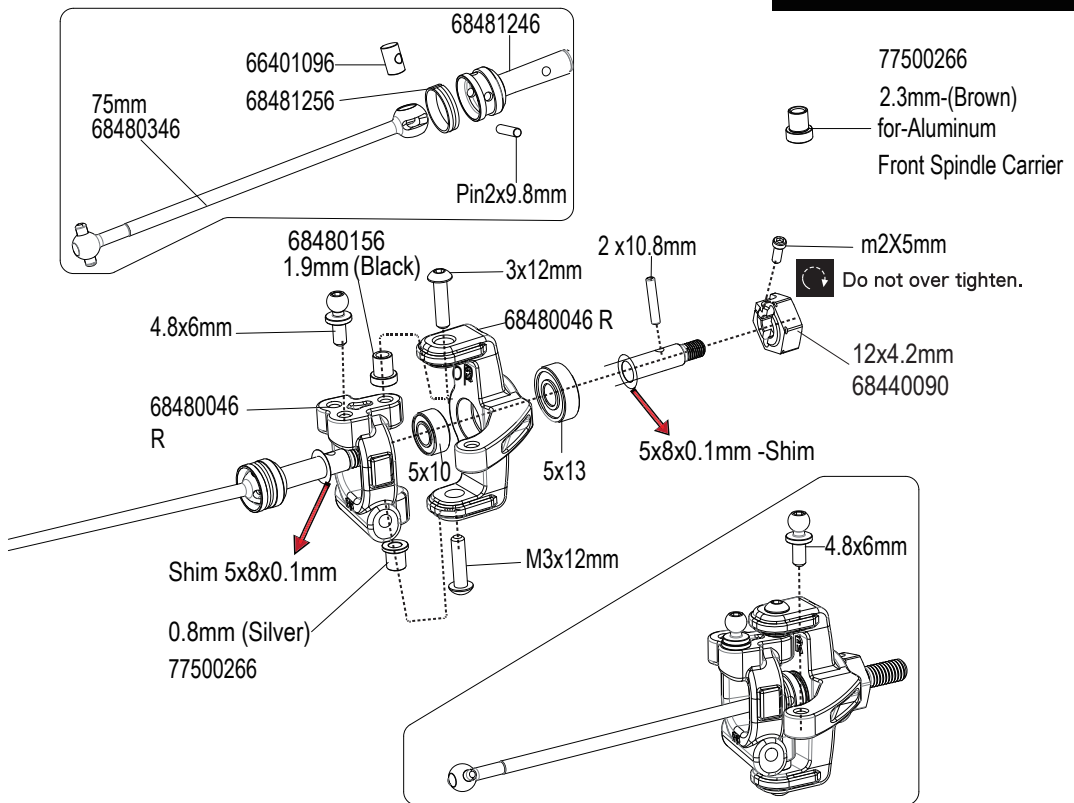



BAG  
B

# B3 Suspension Mount Installation- Sway Bar Installation

- |                        |                                |
|------------------------|--------------------------------|
| 4<br>M3X8mm-82400026   | 2<br>Pin3x36.8mm-66430110      |
| 2<br>M2.5X4mm-80400016 | 2<br>Pin 3x52mm-66430370       |
| 2<br>M3X8mm-80400036   | 2<br>M3X6mm Set Screw-78400026 |

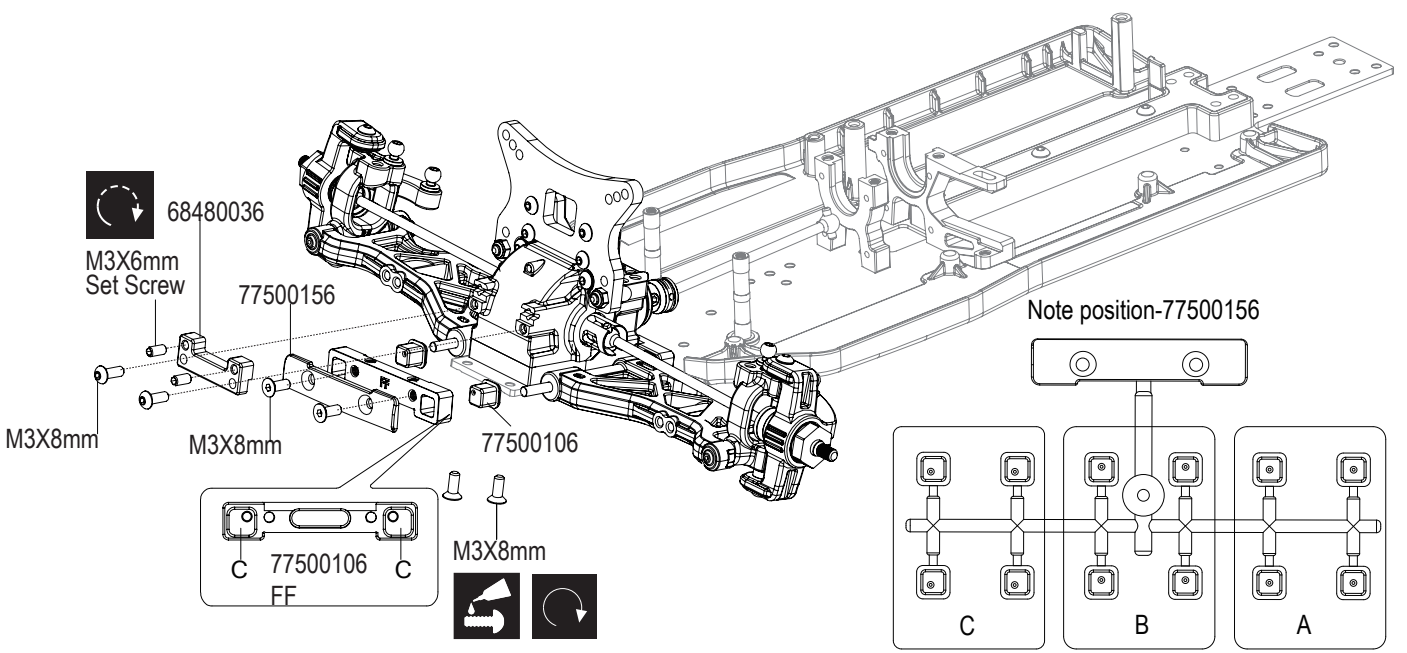
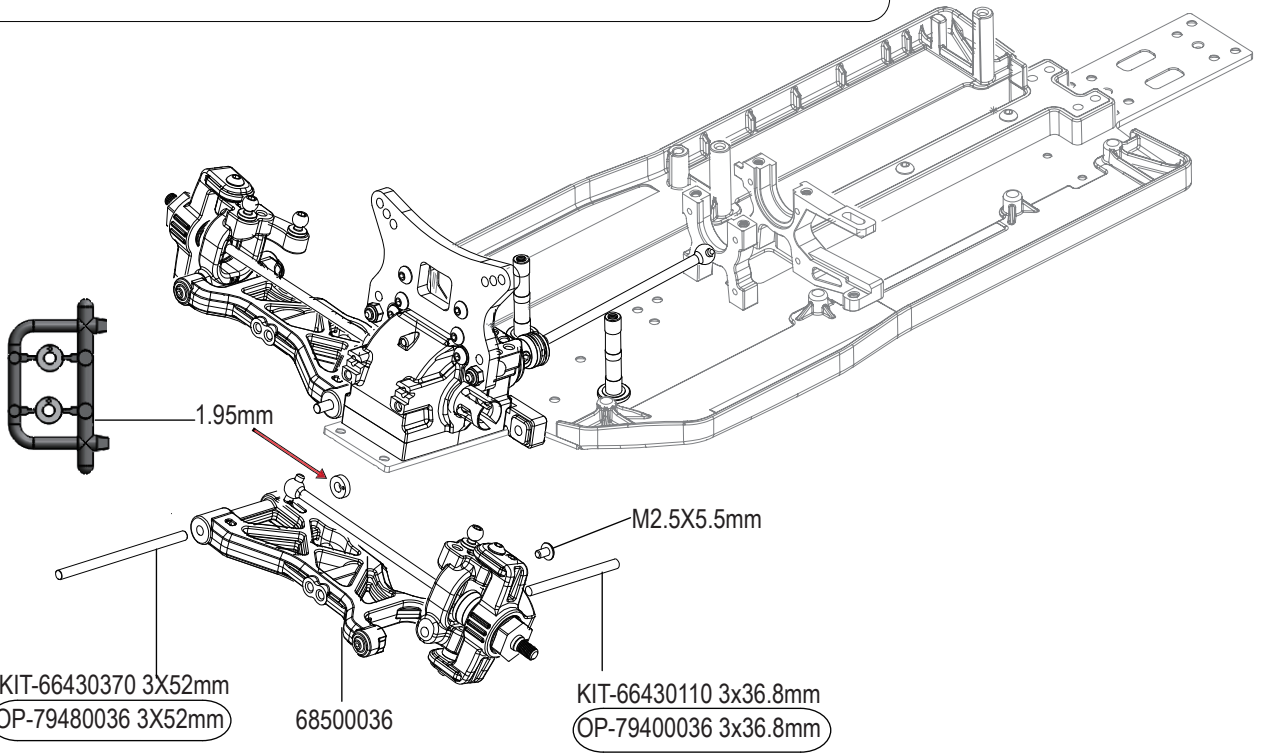

Part Bags used.



Do not over tighten.



Tighten securely.



Apply threadlocker (screw cement)

BAG  
B

# B4 Front Upper Turnbuckle Assembly

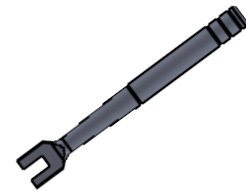
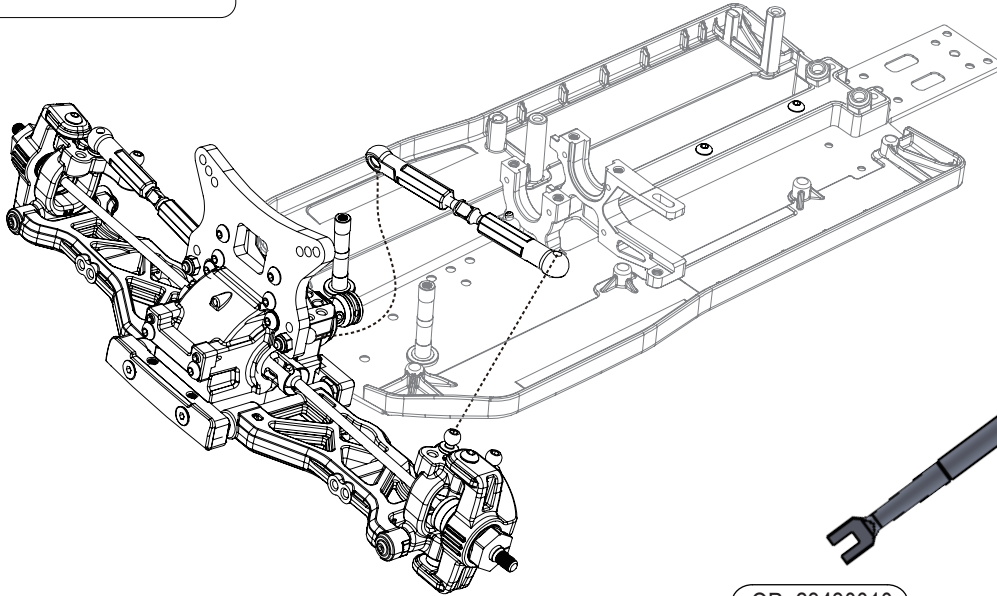
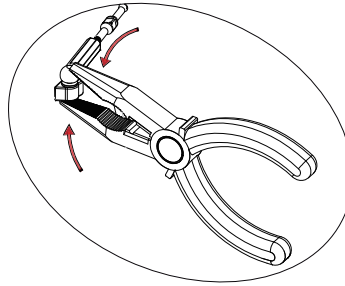
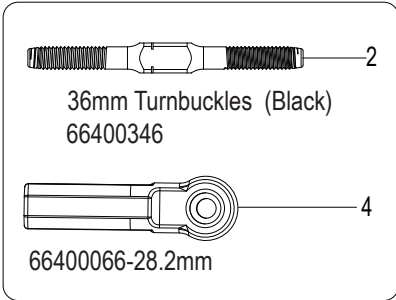

OP -23430010  
PR Tools Spanner Wrench (4.0mm)

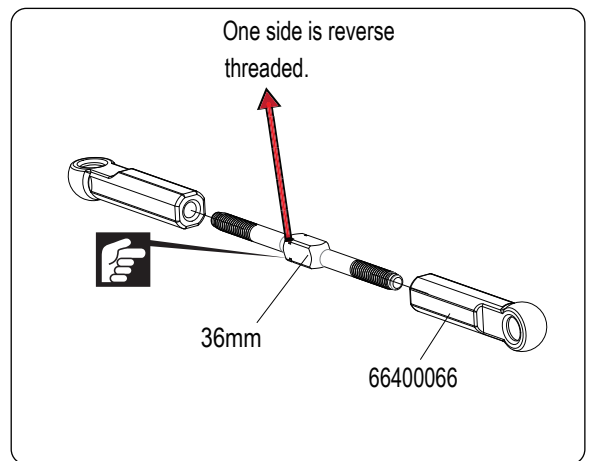
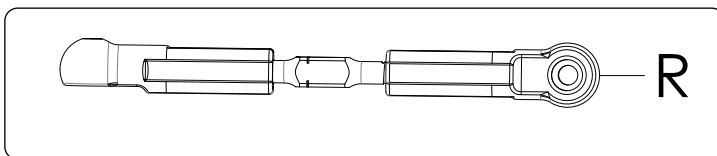
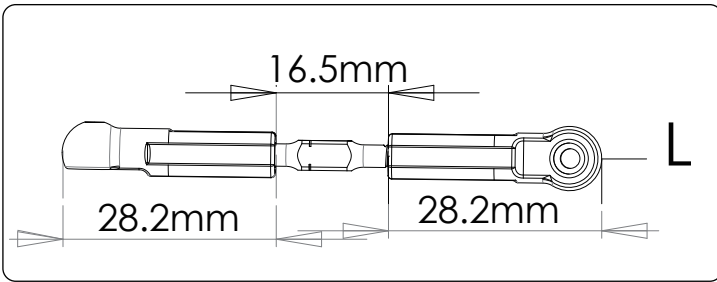



BAG  
C

# C1 RF Suspension Mount

- 4  
M3X10mm 80400046
- 2  
M3X8mm 82400026
- 2  
M3X10mm 82400106
- 2  
M3X15mm 82400176

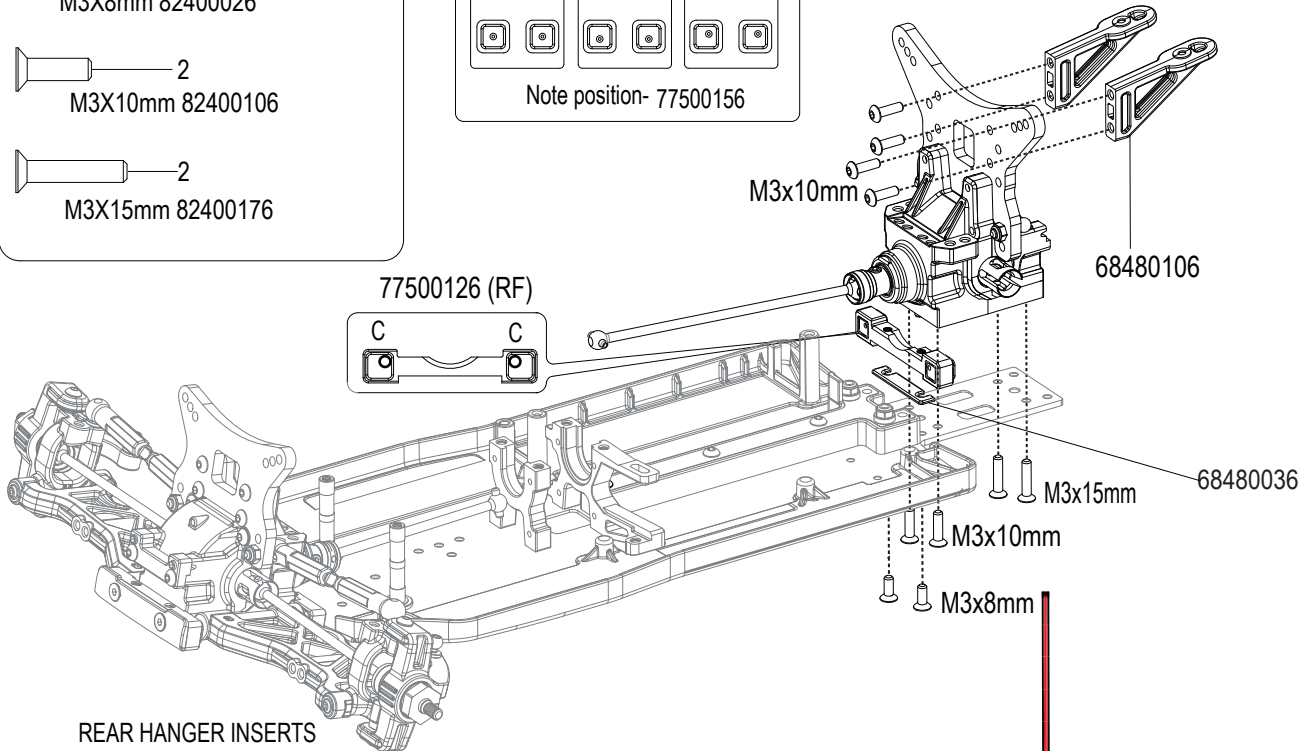
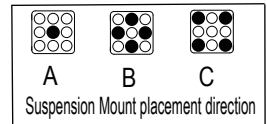
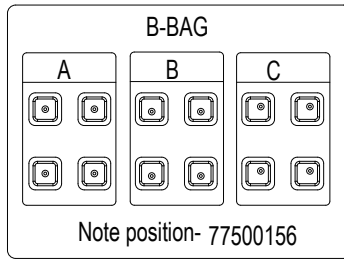

## REAR HANGER INSERTS

Numbering	RF	RR	TOE	SQUAT
R-1			+1.6	0
R-2			+1.6	+0.7
R-3			+1.6	+1.4
R-4			+1.6	-0.7
R-5			+1.6	0
R-6			+1.6	+0.7
R-7			+1.6	-1.4
R-8			+1.6	-0.7
R-9			+1.6	0
R-10			+1.6	0
R-11			+0.8	0
R-12			0	0
R-13			+2.5	0
R-14			+1.6	0
R-15			+0.8	0
R-16			+3.0	0
R-17			+2.5	0
R-18			+1.5	0
R-19			+3.5	+2

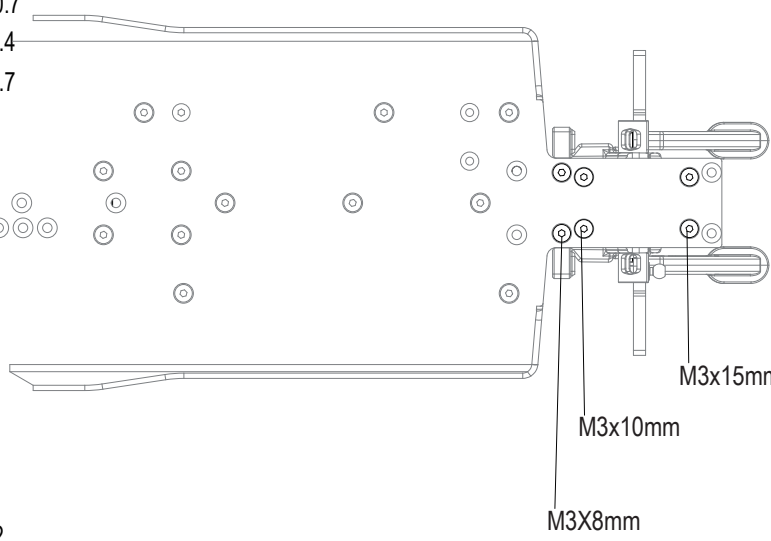

Note: (1) SB401 Plastic Antisquat Shims=1mm=1Degree.

# C2 Rear Left Hub Carrier Assmely



- 2  
M3X8mm 82400026
- 4  
m2.5X4mm 80400016
- 2  
10x15x4mm zz Ball Bearing  
89430030
- 2  
5x13x4mm zz Ball Bearing  
89430020
- 2  
Shim 5x8x0.1mm 85440090
- PIN(3x52mm) 66430370 — 2
- PIN(3x36.8mm) 66430110 — 2
- PIN(2 x 10.8mm) 79400016 — 2
- PIN(2 x 9.8mm) 79400086 — 2
- m2X5mm-87400066 — 2

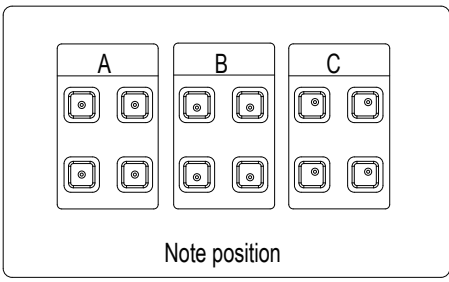
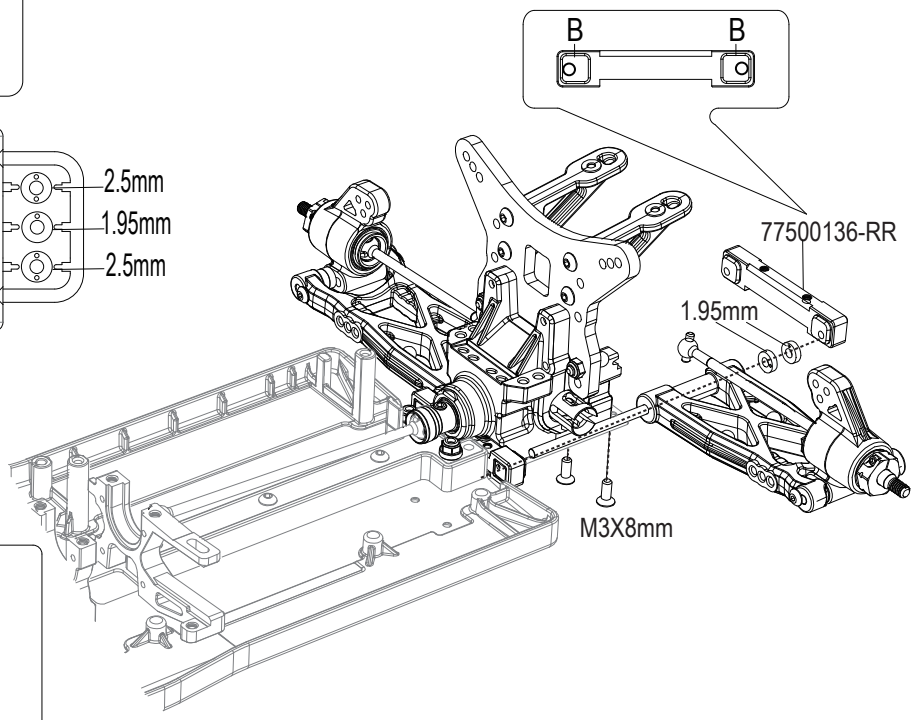
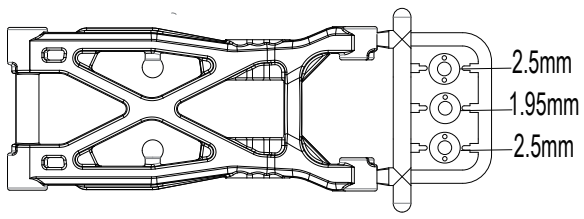
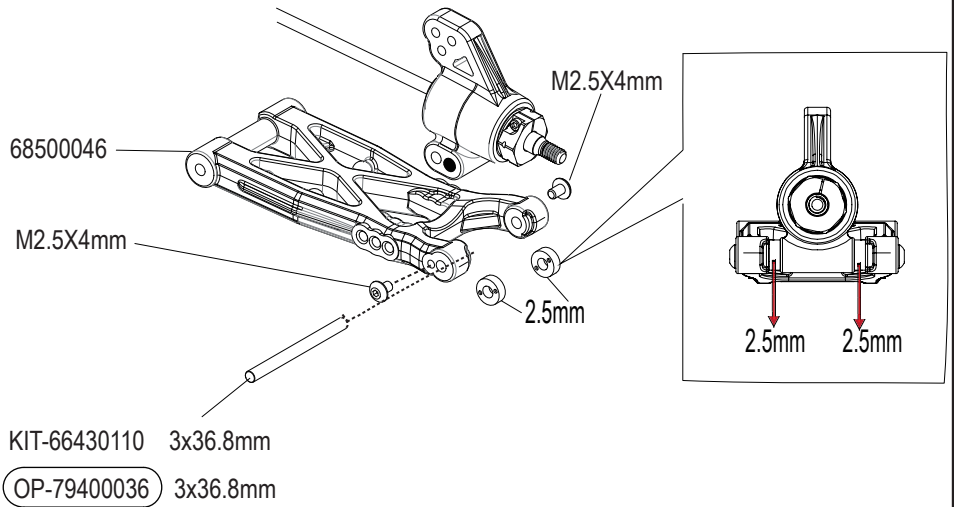
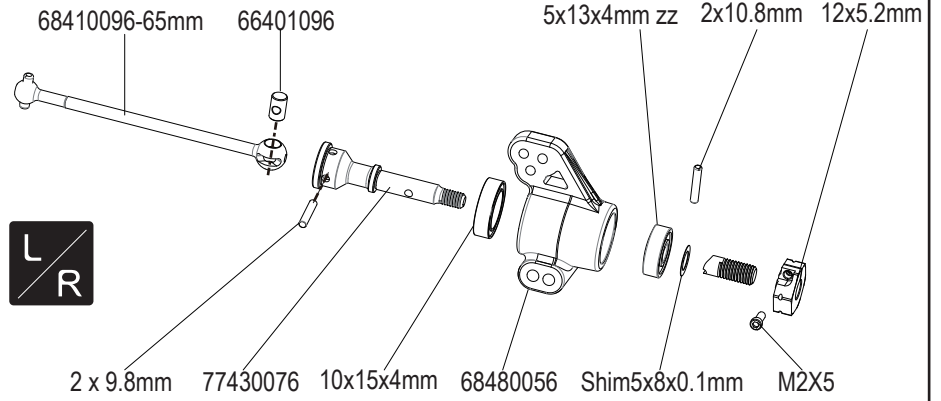





### C3 Rear Upper Rod -Turnbuckle Assembly

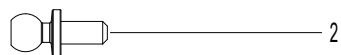

2  
4.8x6mm Ball Studs  
68430036

One side is reversethreaded.

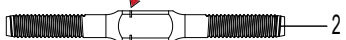

2  
36mm Turnbuckles  
66400346

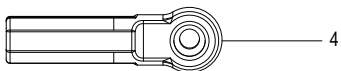

4  
66400066-31.3mm

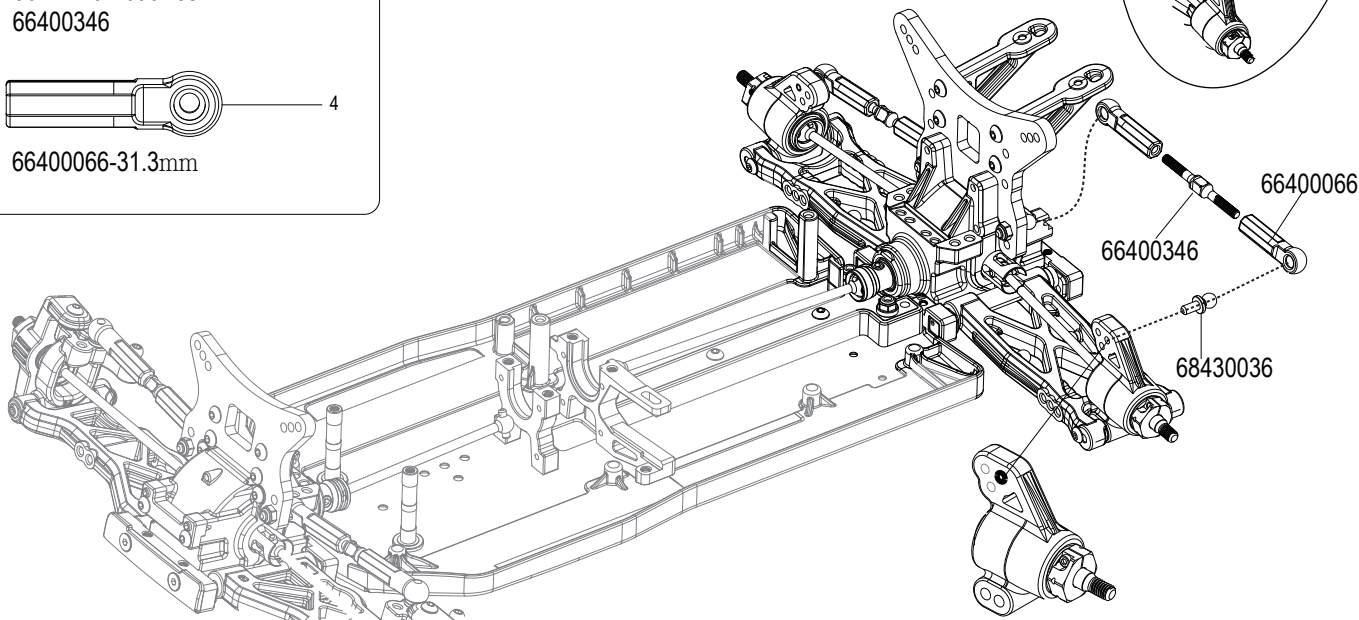
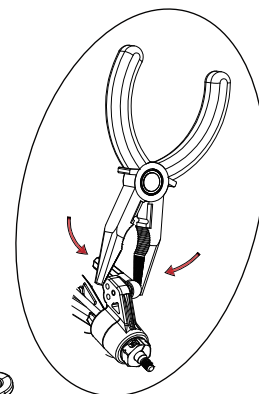
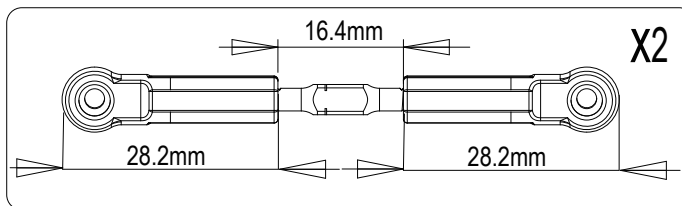

### C4 Sway Bar Installation

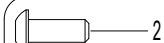

2  
M3X8mm -80400036



2  
M3X6mm Set Screw-78400026

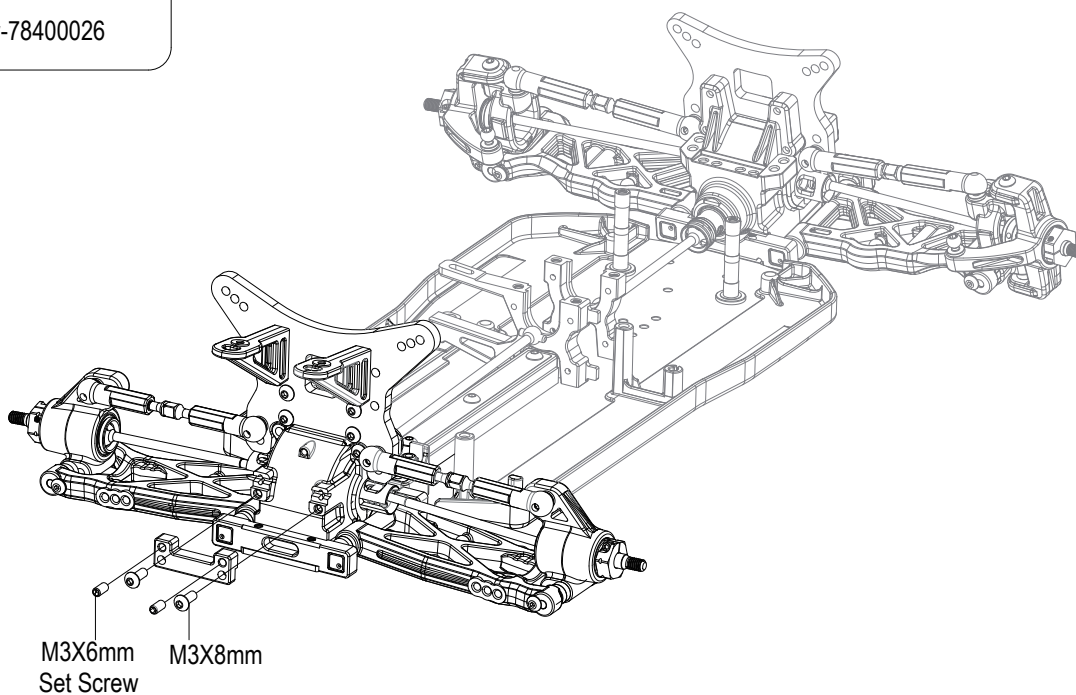

Part Bags used.



One side is reverse threaded.



# D1 Bell Crank Installation

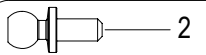

2  
4.8x6mm Ball Studs  
68430036

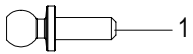

1  
4.8x8mm Ball Studs  
68430046



2  
M3 Lock Nut-83400026

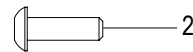

2  
M3x10mm 80400046

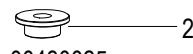

2  
00430025  
Steering Knuckle Bushing  
3x6mm

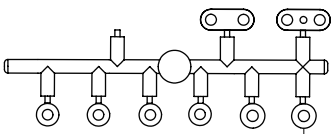

66430200-1.1mm

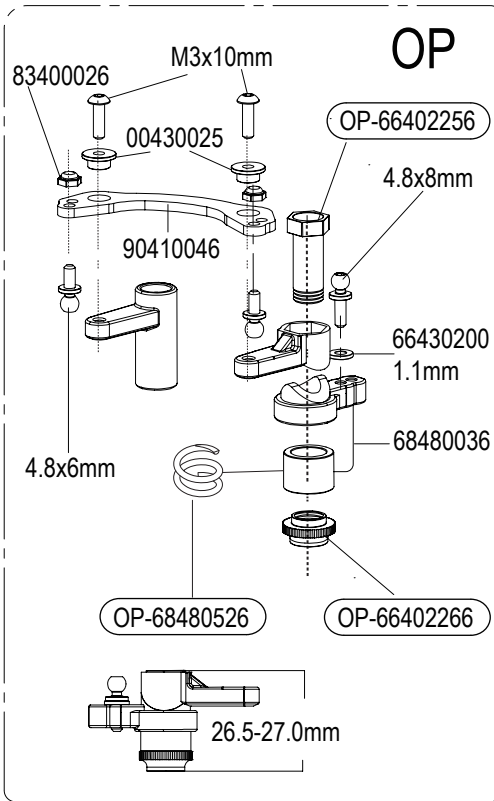

## KIT

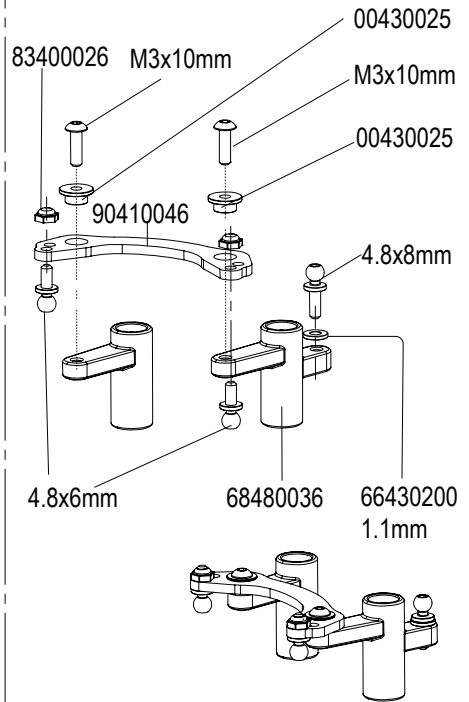

# D2 Steering

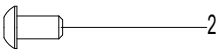

2  
M3x6mm-80400026



4  
5x8x2.5mm Plastic Bearing  
66402106



4  
Shim 5x8x0.2mm  
85440010

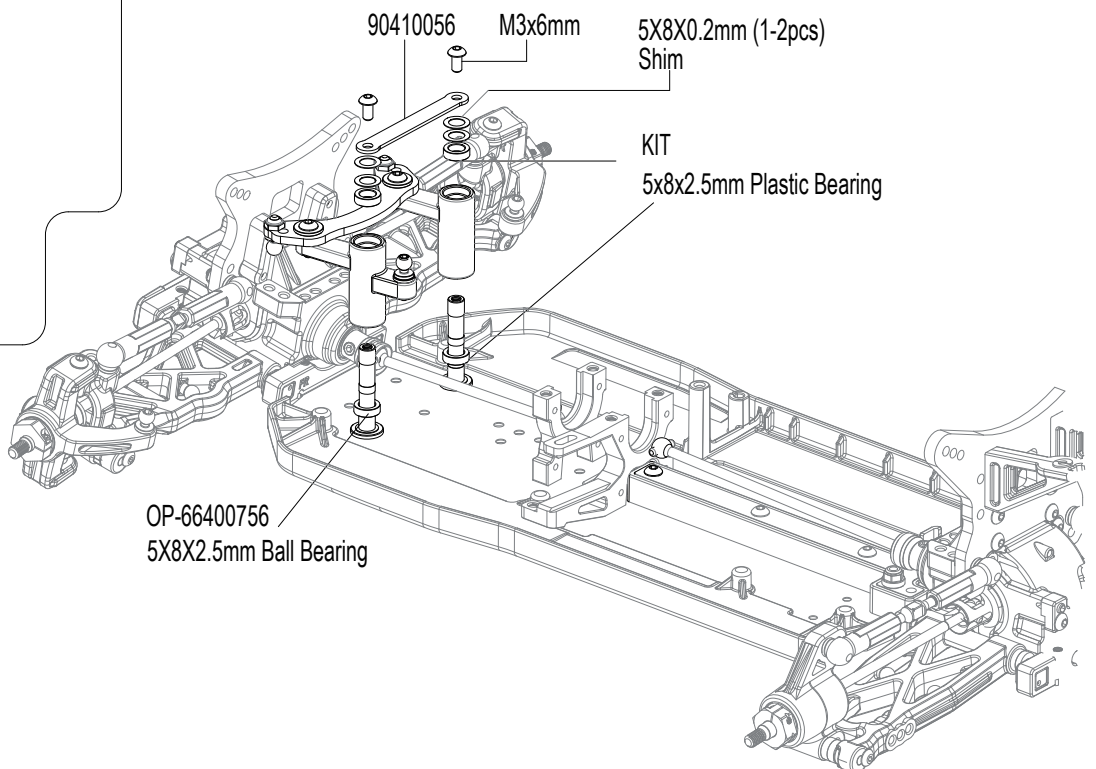



## D3 Turnbuckle Assembly-Steering Rod -Servo Rod

BAG D

One side is reverse threaded.



36mm Turnbuckles  
66400346



Set Screw M3x30mm  
66430130



66400066-28.2mm



66400066-31.3mm

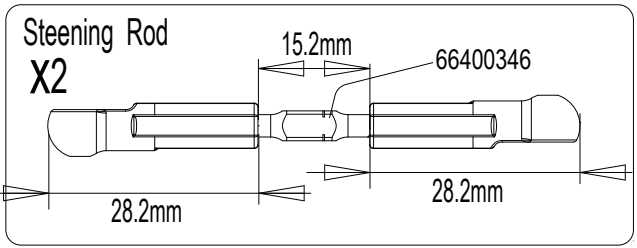
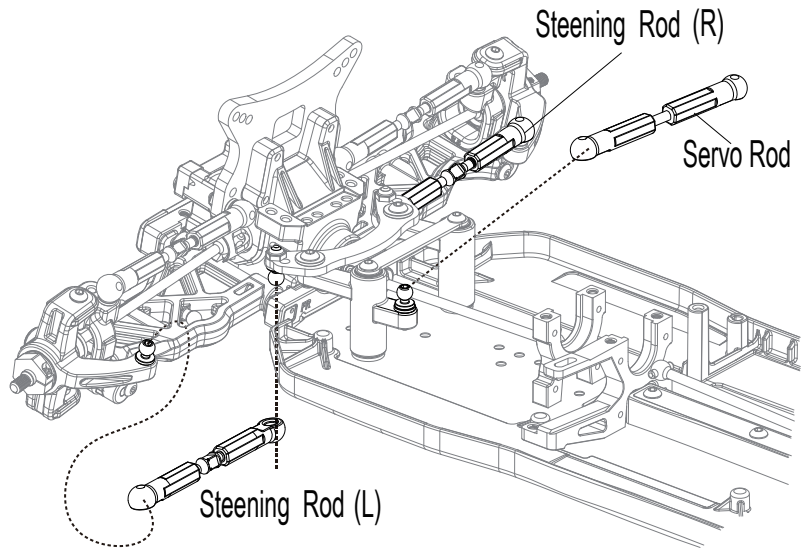
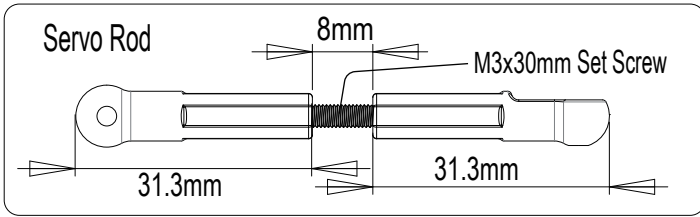

BAG D

## D4 Steering Servo

3  
M3X6mm 80400026

1  
M3x5mm-82400015

4  
M3X10mm 80400046

1  
M3x10mm 82400106

3  
M3X8mm 82400026

1  
M3 Lock Nut  
83400026

1  
68430086  
4.8x6mm-0.8mm

1  
68430086  
4.8x6mm-0.8mm

4  
Silver Aluminum Spacer  
3x6.6x1mm-85440310

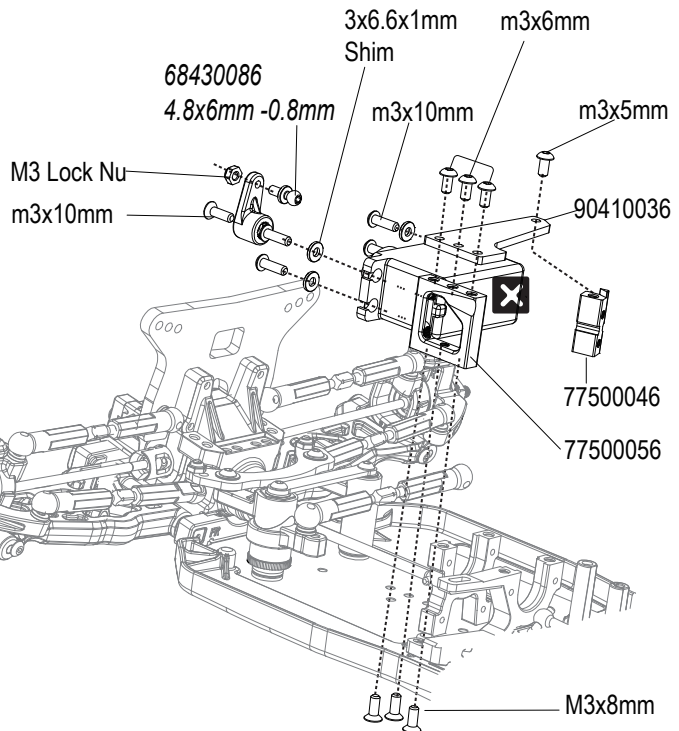

KIT  
Servo  
Installation  
66402466

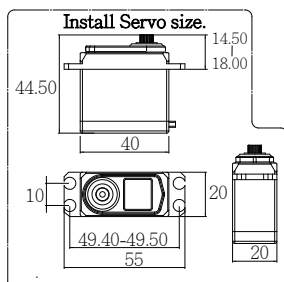
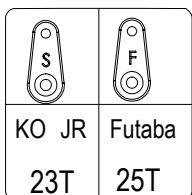

Make sure that the servo is centered before attaching the servo saver horn.  
(Refer to your radio manual for more information)  
Select the servo saver adapter matching the servo being used.

## D5 Center Mount Plate

BAG  
D

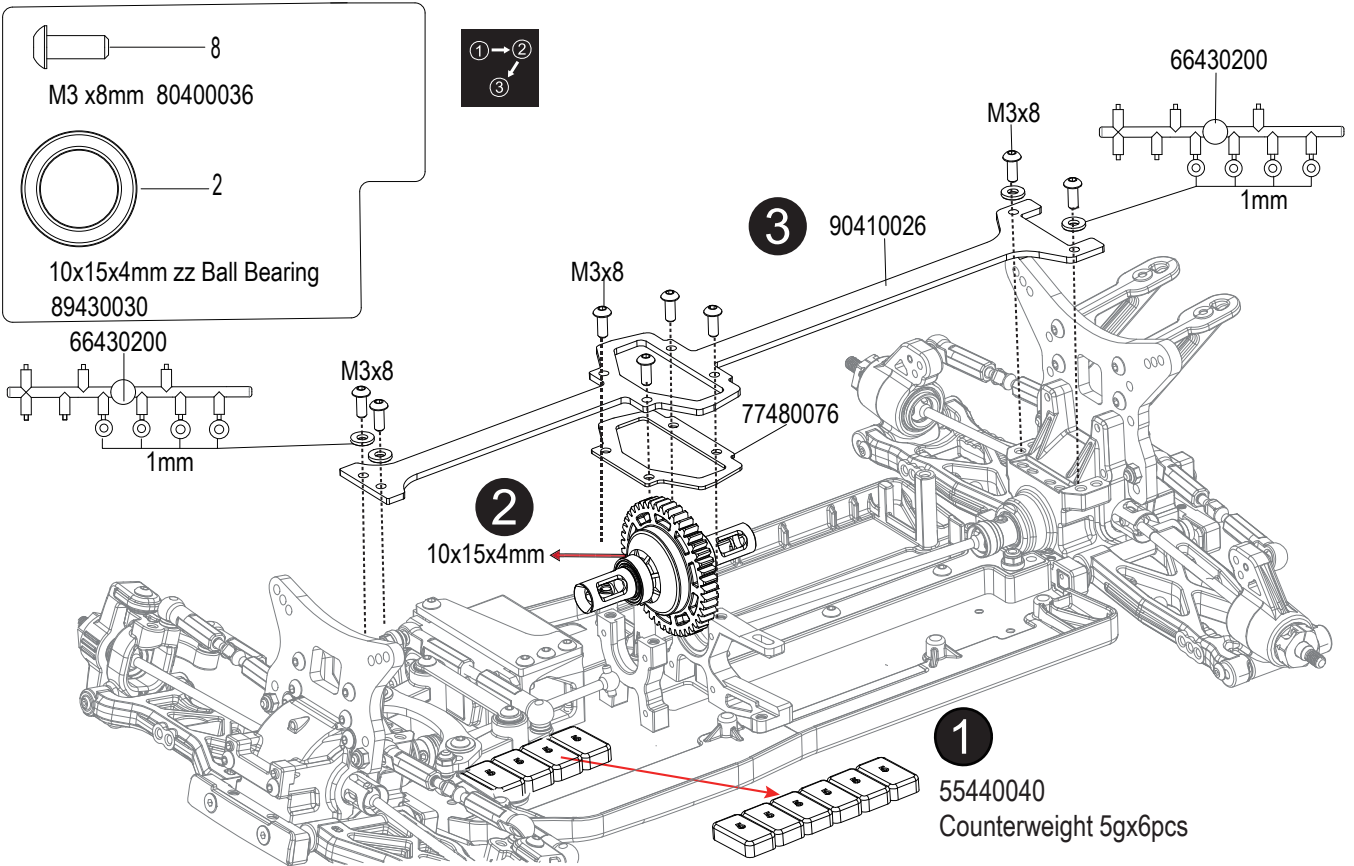

## D6 Battery Plate Installation

BAG  
D

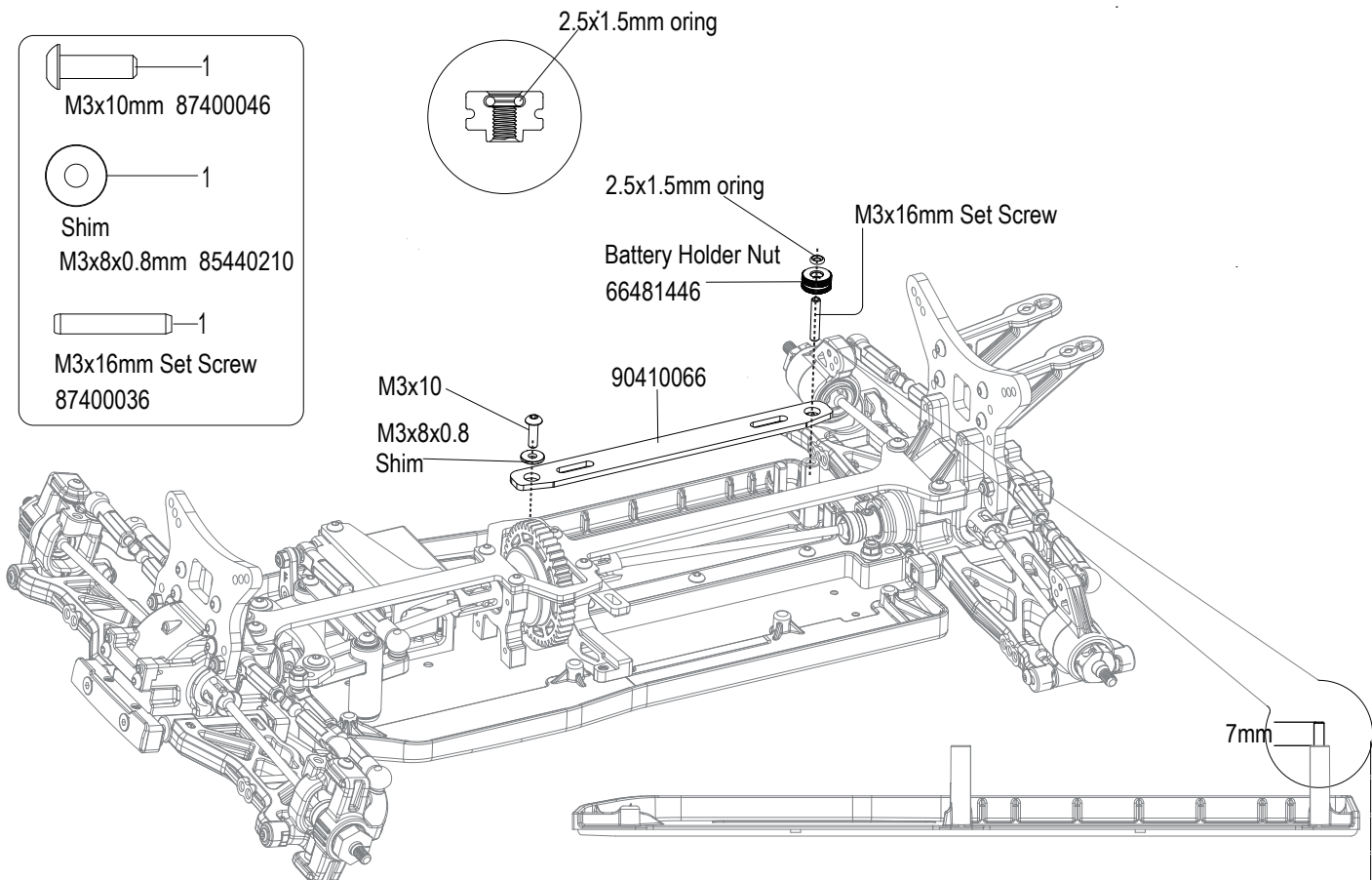



# E1 Front & Rear Shock Assembly-R

BAG E

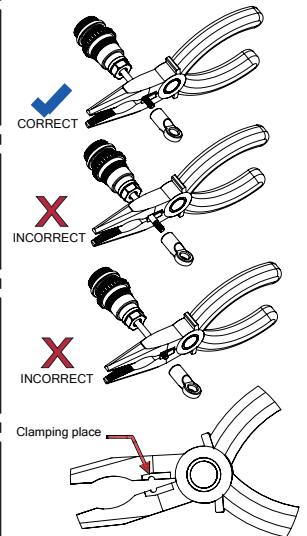
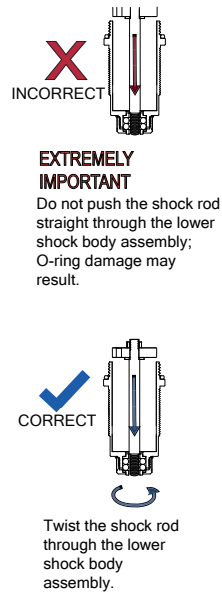
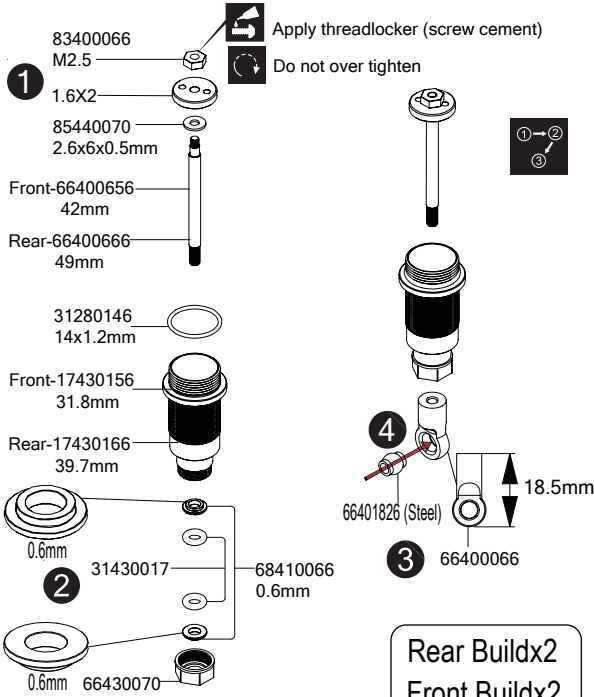
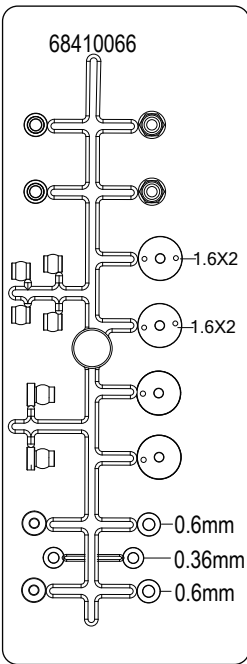

## E1.1

BAG E

After first drive adjust for track conditions

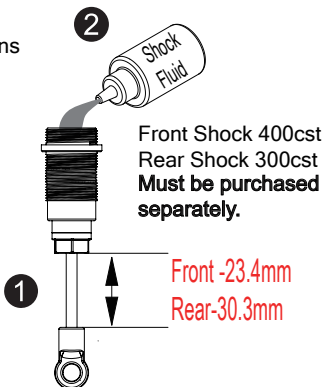

Slowly move up and down to remove air bubbles.

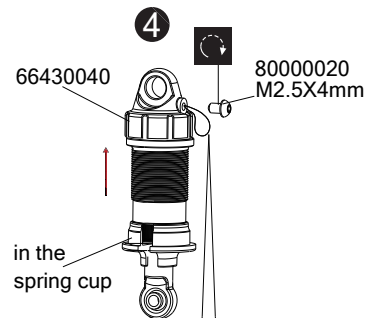
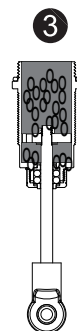

Slowly push the shock shaft all the way up, wipe away any excess oil that has seeped out, and screw in the bleeder screw.

## E1.2

BAG E

### Front Shocks

### Rear Shocks

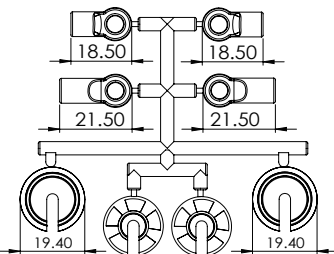

Shock End and Spring Cup Size Description :mm

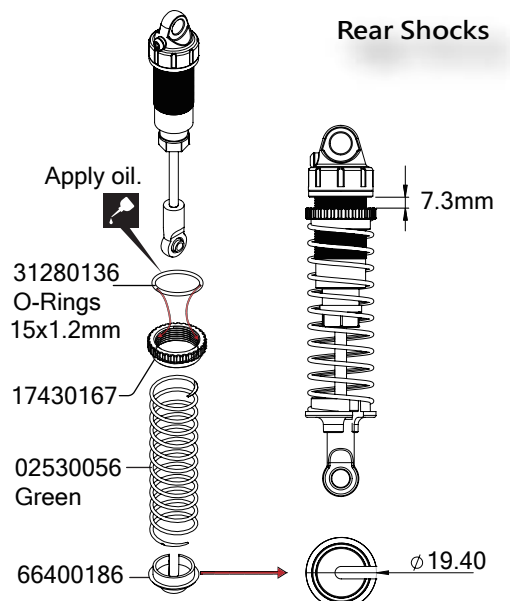
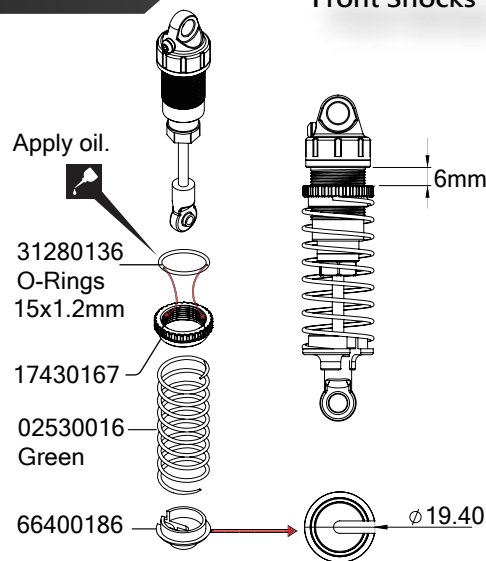

## E2 Front & Rear Shock Installation



- 2 M3 x 28mm 80400126
- 4 M3x14mm 80400056
- 2 M3 x 25mm 80400076
- 4 M3 Nut 83480016

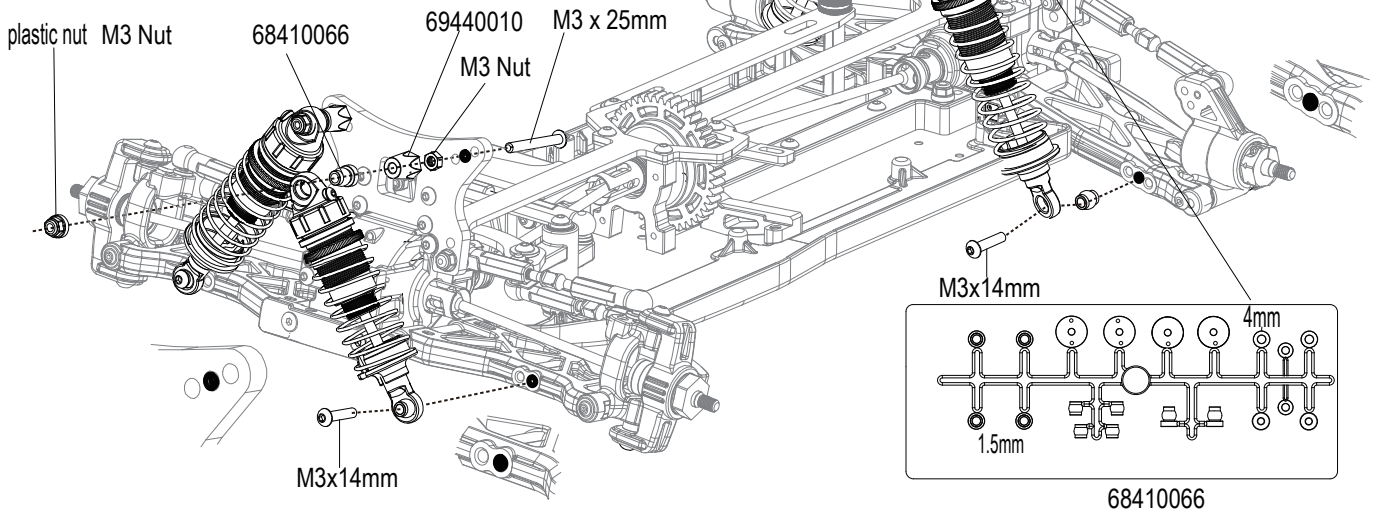
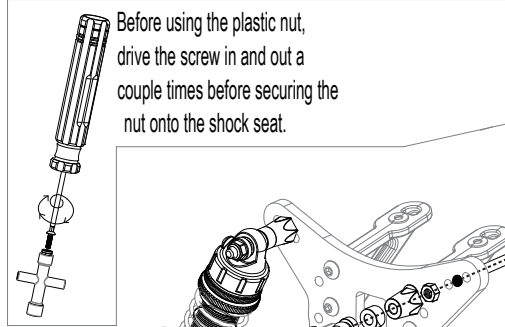

## E3 Motor Installation

- 2 M3 x10mm 80400036
- 2 M3 Antislip Shims 85440240
- 2 M3x12mm 82400036
- 2 3x6x0.5mm Shims 85440301

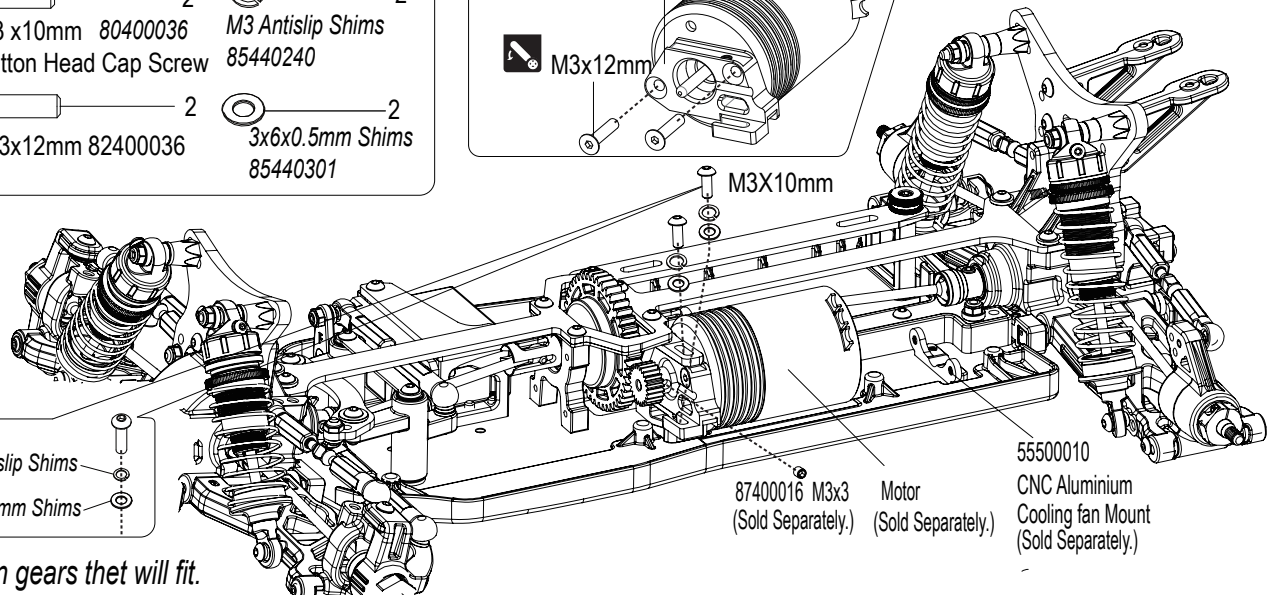
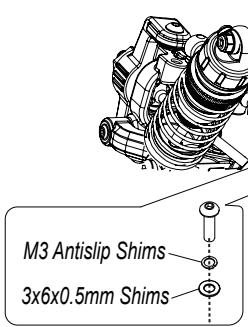
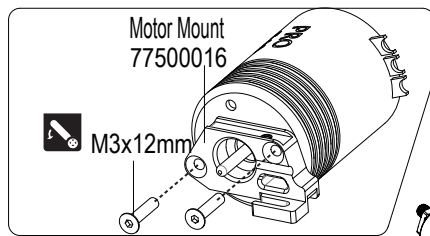



Pinion gears that will fit.

Pinion	17T	18T	19T	20T	21T	22T	23T	24T	25T	26T	27T	28T	29T	30T
73T(Standard)					9.04	8.63	8.25	7.91	7.59	7.30	7.03	6.78	6.54	6.33
75T(Standard)				9.75	9.29	8.86	8.48	8.13	7.80	7.50	7.22	6.96	6.72	
77T(Standard)			10.54	10.01	9.53	9.10	8.70	8.34	8.01	7.70	7.41	7.15		
80T(Standard)		11.56	10.95	10.40	9.90	9.45	9.04	8.67	8.32	8.00	7.70			
81T(Standard)	12.39	11.70	11.08	10.53	10.03	9.57	9.16	8.78	8.42	8.10				



# E4 Mounting Tires Wheel Installation

BAG  
E

-  2  
M3x8mm Flat Head Screws  
82400026
-  4  
M4 Serrated flange nut  
7mm Hex-83400076

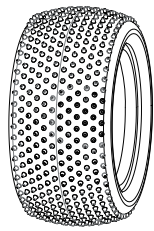

(Sold Separately)

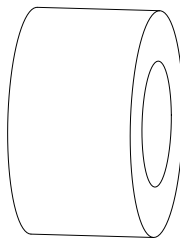

(Sold Separately)

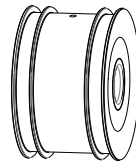

(Sold Separately)

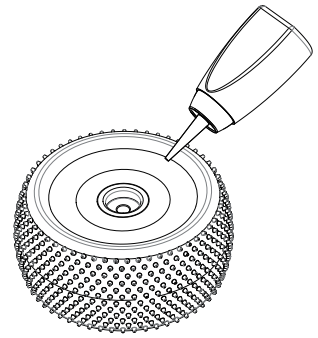

- Place the tire insert into the tire and tire onto the wheel.
- Tire and insert (Sold separately)  
CA(Cyanoacrylate) glue sold separately.

- Pull the sidewall of the tire slightly away from the rim and apply CA(Cyanoacrylate) glue in between the tire bead and rim

## Body and Wing Cutting

\*Wash the inside of the body with luke warm water and a mild soap or detergent (such as liquid dishwashing soap) prior to painting. Oil residue or dust will prevent the paint from adhering to the painting surface, and possibly cause the paint to peel later on. After washing, thoroughly dry the body to allow the paint to adhere properly.

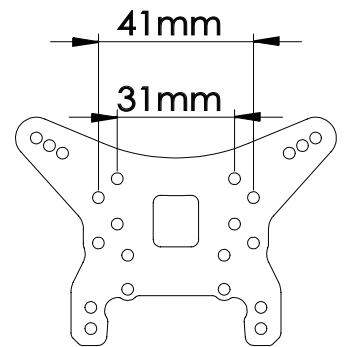
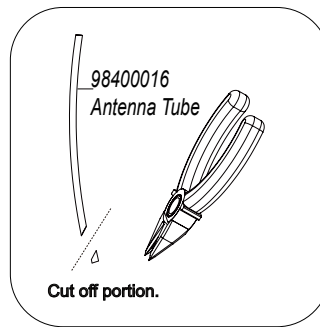

- OP-68481226-PC 0.5mm
- OP-68481076-PC 0.8mm

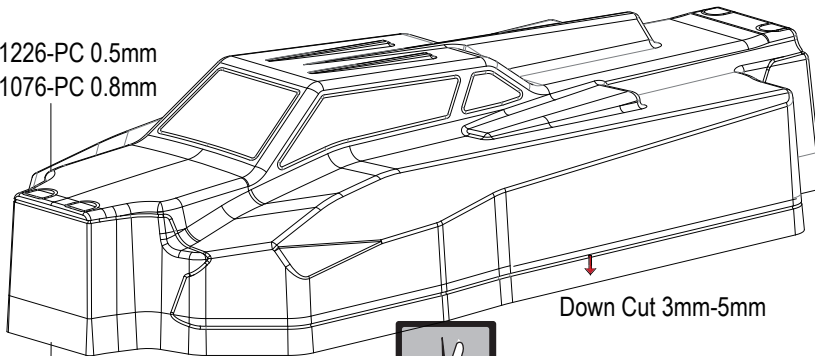

kit-68500056-PVC 0.8mm

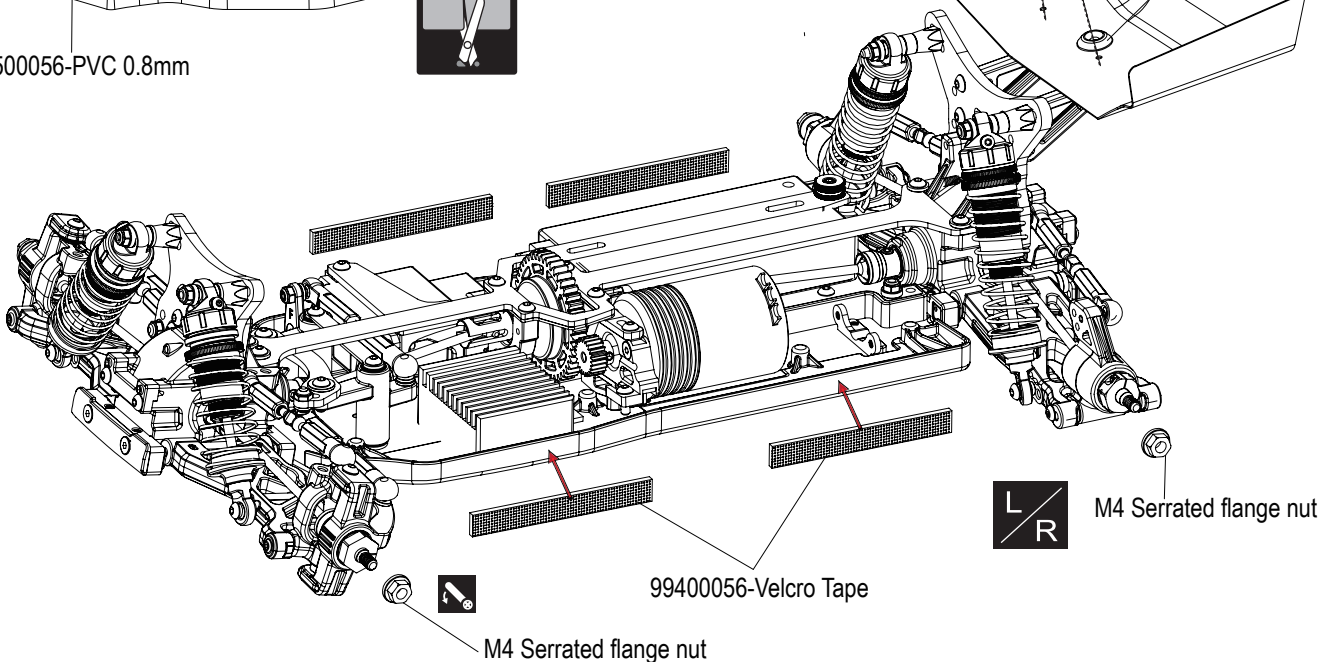
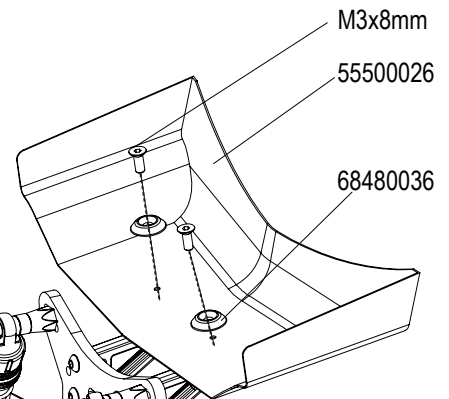

# PR SB401R SPORT

PR SB401R SPORT 1/10 Electric 4wd Off Road Buggy Kit Lightweight Edition  
ITEM NO:.....

DRIVER	DATE
--------	------

## CIRCUIT

- INDOOR  OUTDOOR  DIRT  ASTROTURF  CARPET
- GLASS  WOOD  WET  DRY  DUSTY  SMOOTH
- BUMPY  HARD PACKED  CLAY  BLUE GROOVE
- LOW TRACTION  MED TRACTION  HIGH TRACTION

## FRONT

**CAMBER** \_\_\_\_\_

**TOE IN OUT** \_\_\_\_\_

**RIDE HEIGHT** \_\_\_\_\_

0.8mm  
2.3mm  
Silver 4.2 mm  
Black 5.2 mm  
Brass \_\_\_\_\_ mm

FF FR  
2.3mm 0.8mm

Shock Body  
12.0mm  
12.8mm  
Pom Shim  
0.36mm  
0.6mm

Oil	
Pisyons	Holes mm
Downstop	Shim mm
Up stop	Shim mm
Length	mm
O Rings	<input type="checkbox"/> transparent <input type="checkbox"/> Red

Camber	
Ride Height	mm
TOE In Out	
Type R Shock Spring	

## REAR

**Ride Height** \_\_\_\_\_ mm

**Camber** \_\_\_\_\_ mm

RF RR  
Black \_\_\_\_\_ mm  
Brass \_\_\_\_\_ mm

Shock Body  
12.0mm  
12.8mm  
Pom Shim  
0.36mm  
0.6mm

Oil	
Pisyons	Holes mm
Downstop	Shim mm
Up stop	Shim mm
Length	mm
O Rings	<input type="checkbox"/> transparent <input type="checkbox"/> Red

Camber	
Ride Height	mm
TOE In	
Type R Shock Spring	

MOTOR \_\_\_\_\_ T

GEAR Spur \_\_\_\_\_ T

Pinion \_\_\_\_\_

BATTERY \_\_\_\_\_

ESC \_\_\_\_\_

FRONT TIRE \_\_\_\_\_

INSERTS \_\_\_\_\_

WHEELS \_\_\_\_\_

REAR TIRE \_\_\_\_\_

INSERTS \_\_\_\_\_

WHEELS \_\_\_\_\_

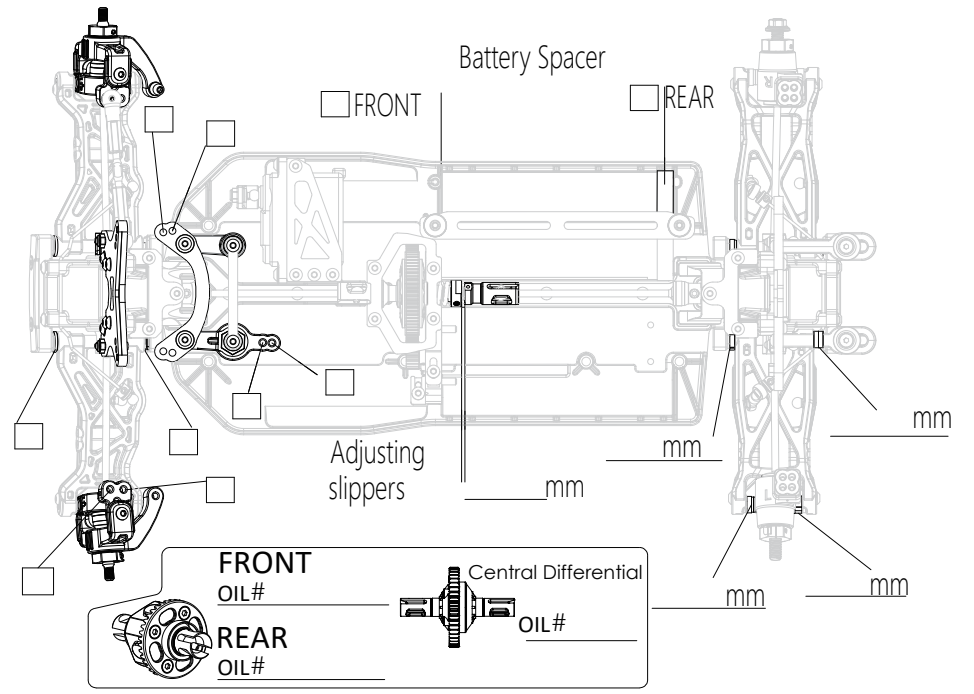

## OTHER



Machined Shock Pistons	Machined Shock Pistons	68470016	55500010
<p>66480716-1.7mm x 2 Hole 66480706-1.6mm x 2 Hole 4PCS</p>	<p>17430116-2.0mm x 2 Hole 17430096-1.8mm x 2 Hole 4PCS</p>	<p>CNC Rear Hub -SB401 R Aluminum 1Set</p>	<p>Cooling fan Mount 1PCS</p>
<p>81430106</p> <p>1Set</p>	<p>66402256</p> <p>1PCS</p>	<p>66402266</p> <p>1PCS</p>	<p>68480526</p> <p>Servo Saver Spring 1PCS</p>
<p>66481256</p> <p>CNC Aluminium 1SET</p>	<p>77500506</p> <p>1SET</p> <p>78mm</p>	<p>68480866</p> <p>1SET</p>	<p>68480976</p> <p>1SET</p>
<p>77480216</p> <p>Aluminum 1PCS</p>	<p>71530016</p> <p>Type R Front Shock Spring Set</p>	<p>71530026</p> <p>Type R Front Shock Spring Set</p>	<p>alloy steel 36mm 6PCS</p>
<p>66400756</p> <p>5x8x2.5mm Ball Bearing (6pcs) 6PCS</p>	<p>77480136</p> <p>Sway Bar Set 1SET</p>	<p>77480160</p> <p>Aluminum Steering Knuckles 1SET</p>	<p>68480956</p> <p>2.5mm Carbon 1pcs</p>
<p>77510010</p> <p>FF Suspension Mount 2mm narrower 1PCS</p>	<p>77510020</p> <p>FR Suspension Mount 2mm narrower 1pcs</p>	<p>79400036</p> <p>alloy steel 3 x 36.8mm 4pcs</p>	<p>79480036</p> <p>alloy steel 3 x 52mm 4pcs</p>
<p>66480356</p> <p>Gear Diff Cross Pins Aluminum 2PCS</p>	<p>68481076</p> <p>R- Body 0.8mm 1PCS</p>	<p>85430016</p> <p>Aluminum Wing Mount Washer 2PCS</p>	<p>77510035</p> <p>1Set</p>
<p>66402697</p> <p>Wing (1.5mm) 1PCS</p>	<p>66400286</p> <p>Wing (1.0mm) 1PCS</p>	<p>77480186</p> <p>1PCS</p> <p>Front Pillar 2.5mm Carbon Signature Versatile</p>	<p>77500096</p> <p>(1pr)</p>
<p>77500026</p> <p>Gearbox Reinforcement Front 1PCS</p>	<p>77500036</p> <p>Gearbox Reinforcement Block - Rear 1PCS</p>	<p>68400326</p> <p>Front Wheel 2PCS</p>	<p>68400316</p> <p>68400316 2PCS</p>

# PR SB40R SPORT



**mit**  
MADE IN TAIWAN



EMAIL / [infopracing@gmail.com](mailto:infopracing@gmail.com)

1.3.2Version